

# A High-Speed Data Transmission of an Redundant Signed Digit -Based Ecc Processor

Shaik Farheen & S. V. Ravi Kumar

<sup>1</sup> PG Scholar, Dept of ECE, Rise Krishna Sai Gandhi Group of Institutions, Ongole, AP, India.

<sup>2</sup> Associate Professor, Dept of ECE, Rise Krishna Sai Gandhi Group of Institutions, Ongole, AP, India.

**ABSTRACT:** *In this paper, an exportable application-specific instruction-set elliptic curve cryptography processor primarily based on redundant signed digit illustration is proposed. The processor employs extensive pipelining techniques for Karatsuba–Ofman approach to obtain excessive throughput multiplication. Furthermore, an efficient modular adder without comparison and a high throughput modular divider, which results in a short data-path for maximized frequency, are implemented. The examination of speed and area overhead among various ECC plans legitimizes the cost-adequacy of the proposed ECC architecture with its design procedure. The Xilinx virtex 5 field programmable gate array has been utilized. The usefulness of the FPGA will be checked by utilizing chip scope pro analyzer. Further the processor is actualized in ASIC CMOS innovation.*

**Index Terms—**Application-specific instruction-set processor (ASIP), elliptic curve cryptography (ECC), field-programmable gate array (FPGA), Karatsuba–Ofman multiplication, redundant signed digit (RSD).

## I. INTRODUCTION

Elliptical curve cryptography (ECC) is an asymmetric cryptographic device that offers an equal security to the famous Rivest, Shamir and Adleman machine with a lot smaller key sizes. The fundamental operation in ECC is scalar factor multiplication, in which a point on the curve is improved by means of a scalar. A scalar factor multiplication is performed with the aid of calculating series of factor additions and point doublings. Using their geometrical properties, factors are added or doubled via series of additives, subtractions, multiplications, and divisions in their respective coordinates. Point coordinates are the factors of finite fields closed beneath a

top or an irreducible polynomial. Various ECC processors had been proposed within the literature that both goal binary fields top fields or dual subject operations. Carry good judgment or embedded virtual sign processing blocks inside Field programmable gate arrays (FPGAs) are also applied in a few designs to deal with the bring propagation hassle. It is important to construct a green addition facts course in view that it is an essential operation employed in different modular arithmetic operations. In order to optimize the multiplication method, a few ECC processors use the divide and conquer approach of Karatsuba of man multiplications, where others use embedded multipliers and DSP blocks inside FPGA fabric. In high subject ECC processors, bring unfastened arithmetic is necessary to avoid prolonged information paths as a result of bring Propagation.

Modular multiplication is a crucial operation in ECC processor. There are two kinds one is as interleaved modular multiplication the use of Bernard Law Montgomery's method when arbitrary curves are required and some other is multiply then reduce and is used in elliptic curves

constructed over finite fields of Messeneprimes which let in green modular reduction thru series of additions and subtraction. Since modular department in affine coordinates is a costly process, different techniques are proposed to compensate the price like jacobian coordinate and fermat's little theorem. ECC processor also uses GSD set of rules. Hence, many ECC processors with combined modular division and multiplication blocks were proposed. The complexity of modular division algorithms is approximately  $O(2n)$ , wherein  $n$  is the size of operands and the strolling time is variable and relies upon immediately on the inputs.

## II. RELATED WORK:

### Elliptic curve cryptography:

It is a public key cryptography based totally on algebraic shape of elliptic curves over finite fields and requires smaller keys to provide equal security. For present day cryptographic functions, an elliptic curve is a plane curve over a finite field which includes points enjoyable the equation alongside a distinguished factor at infinity.

The smoothness of the curve and distinct roots are guaranteed by  $4a^3 + 27b^2 \neq 0$ . Point coordinates are of type integers for an elliptic curve defined by above equation and are the elements of an underlying finite field with operations performed modulo a prime number. Such elliptic curves are known as prime field elliptic curves.

### **Redundant Signed Digits**

The RSD representation is a carry free arithmetic where integers are represented by the difference of two other integers. An integer  $X$  is represented by the difference of its  $x^+$  and  $x^-$  components, where  $x^+$  is the positive component and  $x^-$  is the negative component. The nature of the RSD representation has the advantage of performing addition and subtraction without the need of the two's complement representation. On the other hand, an overhead is introduced due to the redundancy in the integer representation; since an integer in RSD representation requires double wordlength compared with typical two's complement representation. In radix-2 balanced RSD represented integers, digits of such integers are 1, 0 or -1.

### **Karatsuba–Ofman Multiplication:**

The complexity of the regular multiplication using the schoolbook method is  $O(n^2)$ . Karatsuba and Ofman proposed a methodology to perform a multiplication with complexity  $O(n^{1.58})$  by dividing the operands of the multiplication into smaller and equal segments. Having two operands of length  $n$  to be multiplied, the Karatsuba–Ofman methodology suggests to split the two operands into high-(H) and low-(L). The original Karatsuba algorithm is performed recursively, where the operands are segmented into smaller parts until a reasonable size is reached, and then regular multiplications of the smaller segments are performed recursively.

### **III. PROPOSED SYSTEM:**

Due to the dangers of long variety information paths and brief frequency variety in present current systems, a way is proposed to boom frequency variety and decrease the data path variety. This paper proposes a new RSD-based high subject ECC processor with high-pace running frequency. The processor is a utility-particular education-set processor type to provide programmability and configurability. In this paper, we reveal the

overall performance of left-to-right scalar factor multiplication algorithm; however, the ASIP characteristic of the processor allows extraordinary algorithms to be performed via the thru examine-best reminiscence (ROM) programming. The universal processor architecture is of ordinary go bar type with 256 digit huge information buses. The layout method and optimization strategies are focused in the direction of efficient individual modular arithmetic modules in preference to the general architecture. Such architecture permits for clean alternative of man or woman blocks if distinct algorithms or modular arithmetic techniques are preferred. Different efficient architectures of person modular mathematics blocks for diverse algorithms are proposed. The novelty of our processor evolves round the subsequent.

- 1) We introduce the first FPGA implementation of RSD-based ECC processor.
- 2) Extensive pipelining and optimization strategies are used to acquire a high-throughput iterative Karatsuba multiplier which lead to a performance improvement

of just about a hundred% over the processor proposed in.

- 3) To the best of our expertise, the proposed modular department/inversion is the quickest to be accomplished on FPGA tool. This is executed through a new green binary GCD divider architecture based on easy logical operations.

- 4) A modular addition and subtraction is proposed without contrast.

- 5) Most importantly, exportable layout is proposed with specially designed multipliers and conveys unfastened adders that provided in aggressive results against DSPs and embedded multipliers-based designs.

#### **IV. OVERALL PROCESSOR ARCHITECTURE**

The proposed P256 ECC processor consists of AU of 256 RSD digits wide, an finite-state machine (FSM), memory, and two data buses. The processor can be configured in the pre synthesis phase to support the P192 or P224 NIST recommended prime curves processor architecture. Two sub control units are attached to the main control unit as add-on blocks. These two sub control units work as FSMs for point addition and point

doubling, respectively. Different coordinate systems are easily supported by adding corresponding sub control blocks that operate according to the formulas of the coordinate system.

External data enter the processor through the external bus to the 256 RSD digits input bus. Data are sent in binary format and a binary to RSD converter stuffs zeros in between the binary bits in order to create the RSD representation. Hence, 256-bits binary represented integers are converted to 512-bits RSD represented integers. To convert RSD digits to binary format, one needs to subtract the negative component from the positive component of the RSD digit.

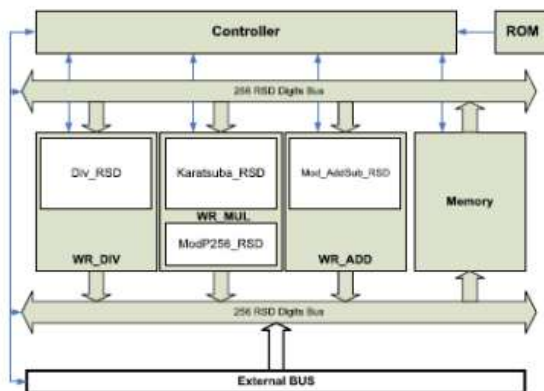

Fig.1. Overall processor architecture

## ARITHMETIC UNIT

The AU is the core unit of the processor that includes the following blocks:

- 1) Modular addition/subtraction block
- 2) Modular multiplication block and
- 3) Modular division block.

### A. Modular Addition and Subtraction

Addition is used in the accumulation process during the multiplication, as well as, in the binary GCD modular divider algorithm. In the proposed implementation, radix-2 RSD representation system as carry free representation is used. In RSD with radix-2, digits are represented by 0, 1, and -1, where digit 0 is coded with 00, digit 1 is coded with 10, and digit -1 is coded with 01. An RSD adder is presented that is built from generalized full adders. The problem with this adder is that it tends to expand the addition result even if there is no overflow, since it restricts the least significant digit (LSD) to be digit -1 only. This unnecessary overflow affects the reduction process later and produces some control complexities in the overall processor architecture. However, the overflow is easily managed when the adder is instantiated as a sub block within a multiplier or a divider as is the case

in the proposed implementation. In order to overcome the problem of overflow introduced a method is proposed consists of two layers, where layer 1 generates the carry and the interim sum, and layer 2 generates the sum, as shown

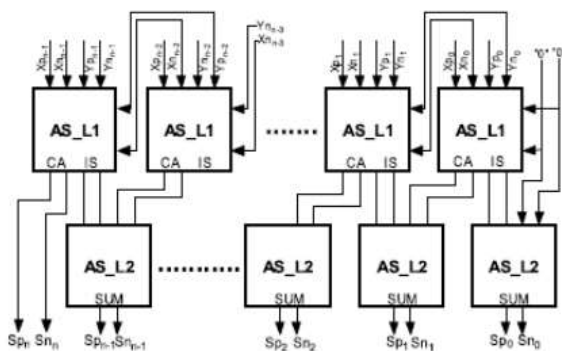

Fig.2. RSD adder/subtractor

The advantage of the proposed modular addition scheme is that only the MSD digits of the intermediate results are checked for the reduction process. Our modular adder/subtractor consists of one full word RSD adder, two full word multiplexers, and one register with some control signals. One modular addition/subtraction is performed within one, two, or three clock cycles as per the value of the MSD that is retrieved after every addition.

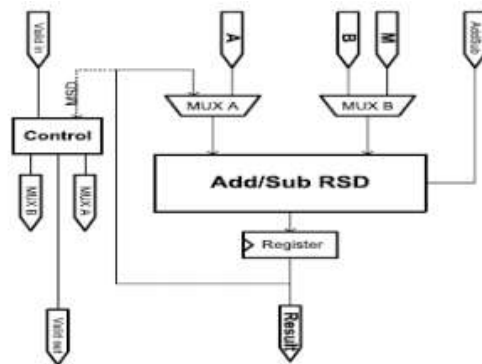

Fig.3. Modular addition subtraction block diagram

### Modular Multiplication

Karatsuba's multiplier recursive nature is considered a major drawback when implemented in hardware. Hardware complexity increases exponentially with the size of the operands to be multiplied. To overcome this drawback, Karatsuba method is applied at two levels. A recursive Karatsuba block that works depthwise, and an iterative Karatsuba that works widthwise. The proposed method consists of two phases: 1) in phase 1, a regular recursive Karatsuba is built through recursive construction down to 1-digit level and 2) the recursive Karatsuba block is used to perform Karatsuba multiplications iteratively. Hence, three recursive Karatsuba blocks are used to

perform single widthwise Karatsuba iteration.

V.

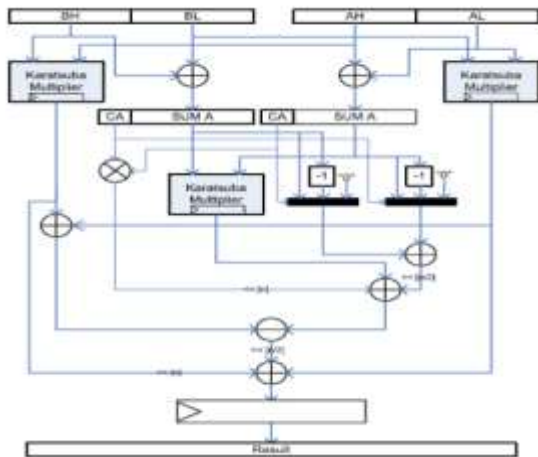

Fig.4. Karatsuba recursive block diagram

### V. CONTROL UNIT AND INSTRUCTION SET

The control unit consists of the main controller of the processor that is an FSM. It also includes two processing units that control the procedures for the point doubling and point addition. In order to process the different coordinate systems, the other processing units can be generated to support them as an add-on feature. Hence, new instructions need to be added to the instruction set to accommodate the new processing units. Different scalar point

multiplication algorithms are supported at instruction level. Different projective coordinate systems and point addition/doubling variations are configured at the control level through add-on processing units. On the other hand, elliptic curves with different finite fields are supported as a resynthesize process.

### VI. SIMULATION RESULTS

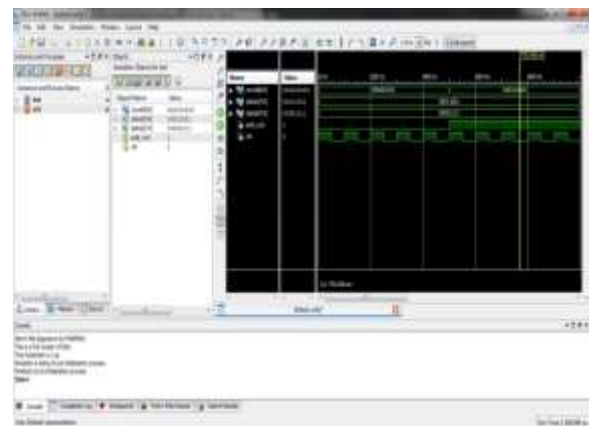

Fig 5: simulation result of the proposed system

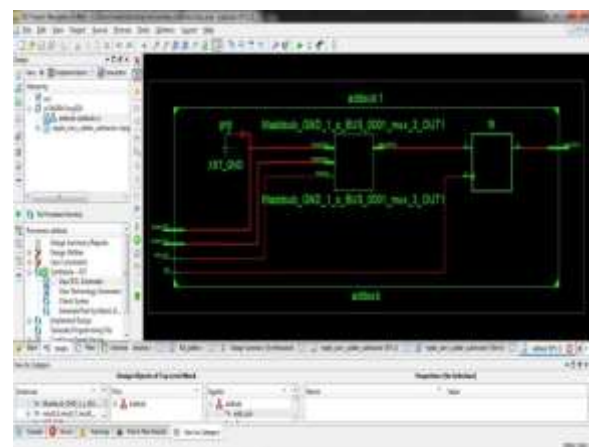

Fig 6: RTL schematic of the proposed system

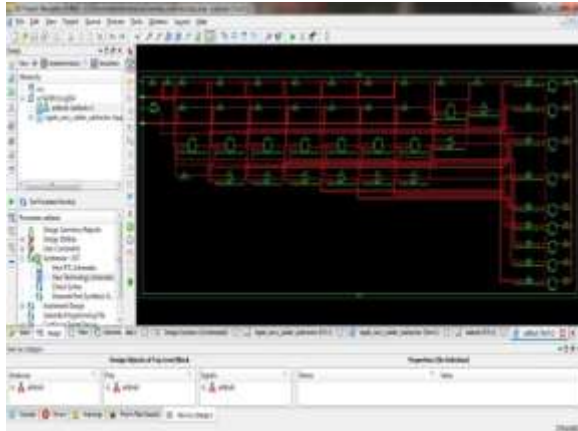

Fig 7: Technology schematic of the proposed system

## VII. CONCLUSION

In this paper, a NIST 256 prime field ECC processor implementation in FPGA has been presented. An RSD as a carry free representation is utilized which resulted in short data paths and increased maximum frequency. We introduced enhanced pipelining techniques within Karatsuba multiplier to achieve high throughput performance by a fully LUT-based FPGA implementation. An efficient binary GCD modular divider with three adders and shifting operations is introduced as well. Furthermore, an efficient modular addition/subtraction is introduced based on

checking the LSD of the operands only. A control unit with add-on like architecture is proposed as a configurability feature to support different point multiplication algorithms and coordinate systems. The implementation results of the proposed processor showed the shortest data path with a maximum frequency of 160 MHz, which is the fastest reported in the literature for ECC processors with fully LUT-based design. A single point multiplication is achieved by the processor within 2.26 ms, which is comparable with ECC processors that are based on embedded multipliers and DSP blocks within the FPGA. The main advantages of our processor include the exportability to other FPGA and ASIC technologies and expandability to support different coordinate systems and point multiplication algorithms.

## REFERENCES

- [1] N. Koblitz, —Elliptic curve cryptosystems,|| *Math. Comput.*, vol. 48,no. 177, pp. 203– 209, Jan. 1987.
- [2] W. Stallings, *Cryptography and Network Security: Principles and Practice*, 5th ed. Englewood Cliffs, NJ, USA: Prentice-Hall, Jan. 2010.



[3] C. Rebeiro, S. S. Roy, and D. Mukhopadhyay, —Pushing the limits of high-speed GF(2<sup>m</sup>) elliptic curve scalar multiplication on FPGAs, in Proc. Cryptograph. Hardw.Embedded Syst. (CHES), vol. 7428, Jan. 2012, pp. 494–511.

[4] Y. Wang and R. Li, —A unified architecture for supporting operations of AES and ECC, in Proc. 4th Int. Symp. Parallel Archit., Algorithms Programm. (PAAP), Dec. 2011, pp. 185–189.

[5] S. Mane, L. Judge, and P. Schaumont, —An integrated prime-field ECDLP hardware accelerator with high-performance modular arithmetic units, in Proc. Int. Conf. Reconfigurable Comput. FPGAs, Nov./Dec. 2011, pp. 198–203.

[6] M. Esmaildoust, D. Schinianakis, H. Javashi, T. Stouraitis, and K. Navi, Efficient RNS implementation of elliptic curve point multiplication over GF(p), in IEEE Trans. Very Large Scale Integr. (VLSI) Syst., vol. 21, no. 8, pp. 1545–1549, Aug. 2012.

[7] D. M. Schinianakis, A. P. Fournaris, H. E. Michail, A. P. Kakarountas, and T. Stouraitis, —An RNS implementation of an F-elliptic curve point multiplier, in IEEE Trans. Circuits Syst. I, Reg. Papers, vol. 56, no. 6, pp. 1202–1213, Jun. 2009.

[8] J.-W. Lee, S.-C. Chung, H.-C. Chang, and C.-Y. Lee, —Efficient power analysis-resistant dual-field elliptic curve cryptographic processor using heterogeneous dual-processing-element architecture, in IEEE

Trans. Very Large Scale Integr. (VLSI) Syst., vol. 22, no. 1, pp. 49–61, Feb. 2013.

#### Author's Profile:



**SHAIK FARHEEN** has received her B.Tech Degree in Electronic Communication Engineering from Pace Institute of Technology and Sciences affiliated to JNTU Kakinada in 2015 and pursuing M.Tech degree in VESD(VLSI&ES) in Rise Krishna Sai Gandhi Group of Institutions, Ongole affiliated to JNTU Kakinada in 2019, AP, India.



**S.V. Ravi Kumar** has received his B.Tech in Electronics & Communications Engineering from QIS College of Engineering & Technology, Ongole, and M.Tech degree in ES & VLSI from A1 Global College of Engineering & Technology, Markapuram, JNTU Kakinada. He is dedicated to teaching field from last 10+ Years. At present he is working as Assistant professor in RISE Krishna Sai Prakasam Group of Institutions, Ongole, affiliated to JNTU Kakinada in AP, India.