

Coordinate Active Power control between Shunt and Series for Balanced/Unbalanced Non-Linear Loads Using UPQC

T.SAMATHA¹, G.UPENDRA RAO²

¹PG scholar, Dept. of EPS, Joginapally Bhaskar Institute of Engineering & Technology, Bhaskar Nagar, Moinabad Mandal, Hyderabad-500075, Telangana, India.

²Assistant Professor, Dept. of EPS, Joginapally Bhaskar Institute of Engineering & Technology, Bhaskar Nagar, Moinabad Mandal, Hyderabad-500075, Telangana, India.

Abstract

This project presents a new concept of coordinated active power sharing between shunt and series converters of unified power quality conditioner (UPQC) for distributed generation applications. The UPQCs are used to mitigate both voltage and current power quality problems. The proposed method improves the utilization of the converters and also the reliability of the system. This paper proposes a new configuration of UPQC that consists of the DC/DC converter and the RES compensating the voltage interruption. The operation of proposed system was verified MATLAB\SIMULINK software.

Index Terms—UPQC, voltage interruption, DC/DC converter, super-capacitor

Introduction

Conventional power systems are affected due to the depletion of fossil fuel energy resources and also increase in the environmental pollution. Consequently, a new trend of distributed power generation integration to the utility distribution network

by using renewable sources is encouraged. Deregulated electricity market and open access to the distribution network are also other reasons for the new trend of distributed generation (DG). The micro grid can be viewed as an active distribution network consists of DG systems and different loads at distribution voltage level. The micro grid can also be treated as a single controlled unit that meets local energy for improving reliability and security [1-3]. The main advantages of the micro grid are uninterruptable power supply, increase in local reliability, reduction in feeder loss and local voltage regulation. A DC micro grid becomes more attractive due to its natural interface to renewable energy sources and energy storage systems [4]. However, a micro grid with DG exhibits like a weak grid and prevails the problem of power quality [5-6]. This DC micro grid is normally interconnected to the power system and local AC load through inverter [7]. However, the single inverter based DG can solve only current related power quality problems in addition to the active power

transfer. Unified power quality conditioner (UPQC) is widely used as an active power filter for improving both voltage and current power quality problems such as voltage sag, voltage swell, voltage harmonics, reactive power compensation, load unbalance and current harmonics etc [8-9]. Energy storage elements such as super capacitors are integrated with the DC link of UPQC to provide active and reactive power support for compensating deep voltage sags and swells for the extended time [10-11]. However, the UPQCs, in general, are used for improving the power quality and not for active power transfer.

POWER QUALITY:

The contemporary container crane industry, like many other industry segments, is often enamored by the bells and whistles, colorful diagnostic displays, high speed performance, and levels of automation that can be achieved. Although these features and their indirectly related computer based enhancements are key issues to an efficient terminal operation, we must not forget the foundation upon which we are building. Power quality is the mortar which bonds the foundation blocks. Power quality also affects terminal operating economics, crane reliability, our environment, and initial investment in power distribution systems to support new crane installations.

To quote the utility company newsletter which accompanied the last monthly issue of my home utility billing: 'Using electricity wisely is a good environmental and business practice which saves you money, reduces emissions from generating plants, and conserves our natural

resources.' As we are all aware, container crane performance requirements continue to increase at an astounding rate. Next generation container cranes, already in the bidding process, will require average power demands of 1500 to 2000 kW – almost double the total average demand three years ago. The rapid increase in power demand levels, an increase in container crane population, SCR converter crane drive retrofits and the large AC and DC drives needed to power and control these cranes will increase awareness of the power quality issue in the very near future.

POWER QUALITY PROBLEMS:

For the purpose of this article, we shall define power quality problems as: 'Any power problem that results in failure or disoperation of customer equipment, manifests itself as an economic burden to the user, or produces negative impacts on the environment.'

When applied to the container crane industry, the power issues which degrade power quality include:

- Power Factor
- Harmonic Distortion
- Voltage Transients
- Voltage Sags or Dips
- Voltage Swells

The AC and DC variable speed drives used on board harbor cranes are noteworthy supporters of aggregate consonant current and voltage contortion. Though SCR stage control makes the alluring normal power factor, DC SCR drives work at not as much as this. What's more, line indenting happens when SCR's commutate, making transient pinnacle recuperation voltages that can be 3

to 4 times the ostensible line voltage relying on the framework impedance and the measure of the drives. The recurrence and seriousness of these power framework unsettling influences fluctuates with the speed of the drive. Consonant current infusion by AC and DC drives will be most noteworthy when the drives are working at moderate rates. Power factor will be most reduced when DC drives are working at moderate paces or amid beginning quickening and deceleration periods, expanding to its greatest esteem when the SCR's are staged on to create appraised or base speed.

UNIFIED POWER QUALITY CONDITIONER:

The arrangement of both DSTATCOM and DVR can control the power nature of the source current and the heap transport voltage. Likewise, if the DVR and STATCOM are associated on the DC side, the DC transport voltage can be managed by the shunt associated DSTATCOM while the DVR supplies the expected vitality to the heap if there should be an occurrence of the transient unsettling influences in source voltage. The setup of such a gadget (named as Unified Power Quality Conditioner (UPQC)) is appeared in Fig 3.14. This is a flexible gadget like an UPFC. Notwithstanding, the control goals of an UPQC are very not quite the same as that of an UPFC.

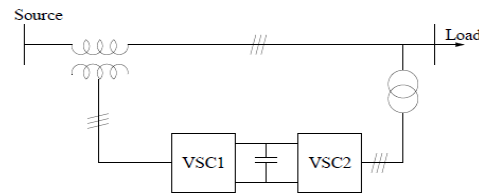

guration of UPQC

confi

CONTROL OBJECTIVES OF UPQC:

a) The shunt associated converter has the accompanying control destinations

1. To adjust the source streams by infusing negative and zero arrangement parts required by the load
 2. The make up for the sounds in the load current by inject the required harmonic current
 3. To control the power factor by infusing the required reactive current (at key recurrence)
 4. To control the DC transport voltage. To adjust the voltages at the load transport by infusing negative and zero arrangement voltages to make up for those present in the source.
- To detach the load transport from harmonics introduces in the source voltages, by injecting the consonant voltages
3. To direct the extent of the load transport voltage by infusing the required active and responsive segments (at principal recurrence) contingent upon the power factor on the source side

ULTRA CAPACITORS:

Ultra capacitors are electrical energy storage devices that have the ability to store a large amount of electrical charge. Unlike the resistor, which dissipates energy in the form of heat, the ideal capacitor does not lose its energy. We have also seen that the simplest form of a capacitor is two parallel conducting metal plates which are separated

by an insulating material, such as air, mica, paper, ceramic, etc, and called the dielectric through a distance, “d”.Capacitors store energy as a result of their ability to store charge with the amount of charge stored on a capacitor depending on the voltage, V applied across its plates, and the greater the voltage, the more charge will be stored by the capacitor as: $Q \propto V$.



A Typical Ultra-capacitor

Also, a capacitor has a constant of proportionality, called capacitance, symbol C, which represents the capacitor’s ability or capacity to store an electrical charge with the amount of charge depending on a capacitor capacitance value as: $Q \propto C$.Then we can see that there is a relationship between the charge, Q, voltage V and capacitance C, and the larger the capacitance, the higher is the amount of charge stored on a capacitor for the same amount of voltage and we can define this relationship for a capacitor as being:

Charge on a Capacitor $Q = C \times V$

Where: Q (Charge, in Coulombs) = C (Capacitance, in Farads) times V (Voltage, in Volts)

SERIES CONVERTER CONTROLLING

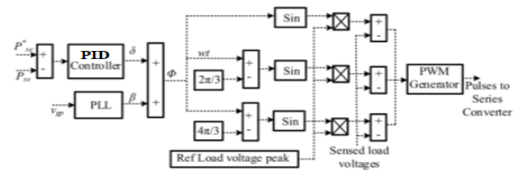

Control block for series control

The main purpose of the series converter is to improve the voltage power quality and also to transfer active power. The voltage power quality problems are eliminated by injecting the voltage in series through series transformer. The active power is transferred through the series transformer by phase shifting the load voltage from the grid voltage. So, the reference load voltage is generated in such a way to inject active power and also to improve the voltage power quality at the load terminals. The phasor diagram for the basic understanding of series converter voltage injection scheme is shown in Fig 5.3. The control schematic for the series converter is presented in Fig 5.2. The maximum active power that can be transferred through the series converter depends upon the kVA rating of the converter. The calculation of the maximum active power injection through the series converter is presented in the following section. As shown in Fig 5.3, the load voltage (vl) is shifted by power angle in such a way that the required amount of active power is transferred through the series converter. Estimation of this power angle is achieved by using a proportional integral differential (PID) controller. The phase angle gives the exact position of the grid voltage from the absolute phasor reference,

which is obtained from the phase locked loop (PLL). The angle of the reference load voltage is obtained by adding power angle and the grid voltage angle. The magnitude of the load voltage V_l is normally selected as a rated peak phase voltage. So, the reference load voltages (v_{labc}^*) are calculated from the reference load voltage magnitude V_l and the phase angle. The PWM pulses are generated for the series converter by comparing the reference load voltages (v_{labc}^*) with the sensed load voltages (v_{labc}).

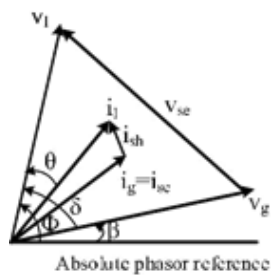

Phasor of series converter

SHUNT CONVERTER CONTROLLING

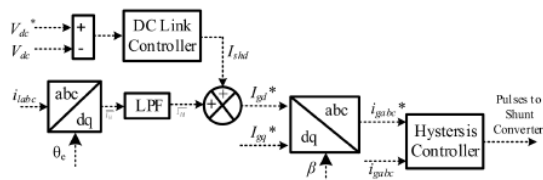

control block of shunt converter

A shunt active filter is used to transfer the active power from the DG in addition to the basic responsibilities such as load current harmonics compensation and load reactive power compensation. So, the shunt converter current consists of load current harmonics, the reactive component of load

current and active power component of shunt converter current. However, indirect current control method is adapted for controlling the shunt converter. So, the grid currents are taken as reference, which should be free from harmonics. The complete control scheme for the shunt converter is presented in Fig 5.4. By applying KCL at the load terminal, the grid currents are the summation of load currents and shunt converter currents. So, the active component of the grid current consists of the active component of the fundamental load current and also the active component of the shunt converter currents. The active component of fundamental load current is calculated from the sensed load currents. Sensed load currents are converted in to synchronous reference frame using the grid voltage angle. The direct and quadrature axis components of the load currents (i_{ld} and i_{lq}) comprises the fundamental (i_{ld}) and harmonic component (i_{ld}) of the load current. The fundamental component of the load current (i_{ld}) is extracted using low pass filter. The DC/DC converter control works in charge mode or discharge mode selectively, depending on the direction from the system manager. In charge mode, the system manager monitors whether the voltage level of the super-capacitors exceeds the maximum operation voltage or not. If the voltage level reaches the maximum value, the DC/DC converter works in standby mode. In discharge mode, the system manager monitors whether the voltage level of the super-capacitors drops lower than the minimum operation voltage or not. If the voltage level reaches the minimum value, the

DC/DC converter shuts down to stop supplying power to the load.

DC/DC CONVERTER DESIGN:

The DC/DC converter can operate in bi-directional mode using soft-switching Scheme (The operation voltage of the RES is in the range between 60-75V, while the dc link voltage is about 700V. The ground point in dc link should be isolated from the ground point in the super-capacitor bank. The converter should have high current rating in bank side and high voltage rating in DC link side. Considering these requirements, a DC/DC converter with two full-bridges was selected as shown in Figure

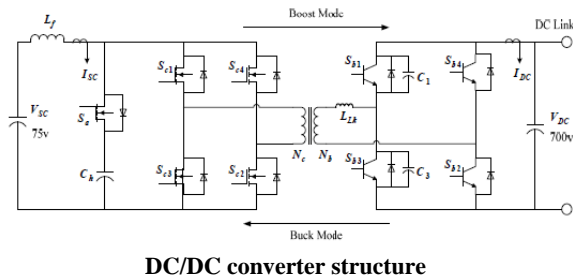

A filter reactor is inserted between the bank and the full-bridge to reduce the ripple of charging and discharging current, which can reduce the lifetime of super-capacitors due to unwanted heat generation. The full-bridge in bank side works as a current-fed type, while the full-bridge in DC link side works as voltage-fed type.

SIMULATION RESULTS:

SIMULATION CIRCUIT:

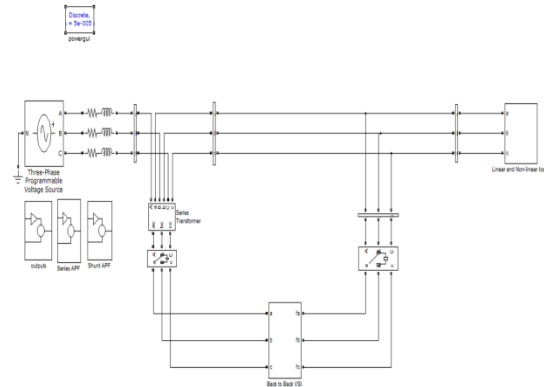

When there is a sag in the system the UPQC detects it and with the help of storage device it generates voltage i.e it injects the required voltage into the system with the help of series converter and maintains the voltage.

SERIES ACTIVE POWER FILTER :

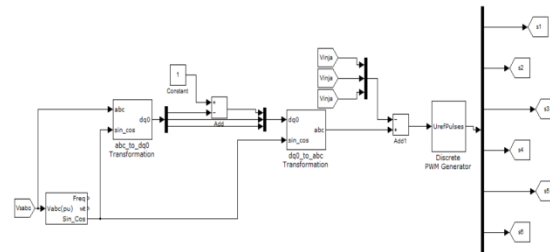

SHUNT ACTIVE POWER FILTER

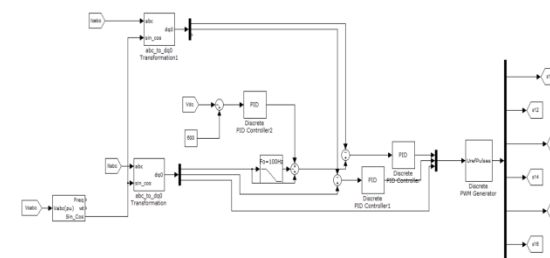

VOLTAGE SAG SIMULATION

RESULTS:

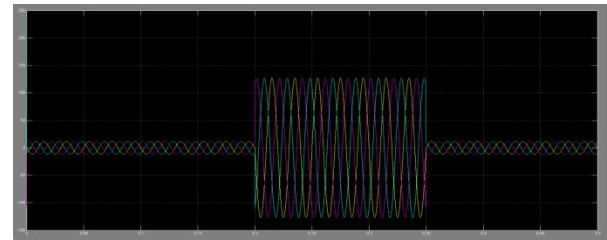
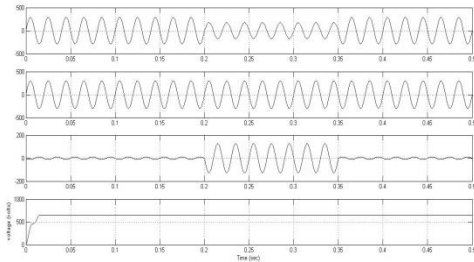

LOAD VOLTAGES OF 3-PHASES

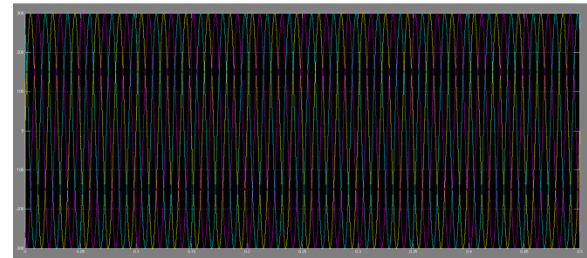

Which improves the reliability and power quality of the system under voltage sag conditions. When there is a swell in the system the UPQC detects it and observes the extra voltage from the system with the help of shunt converter and maintains the voltage. Which improves the reliability and power quality of the system under voltage swell conditions

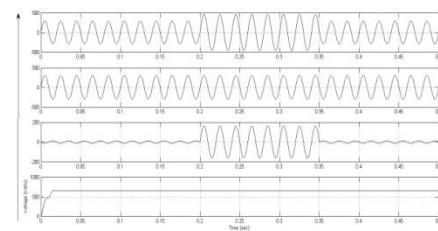

Voltages of source, load, absorbed, DC

SOURCE VOLTAGE OF 3-PHASES

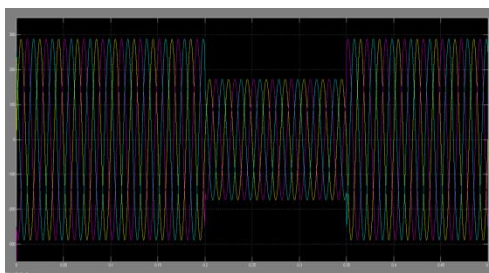

INJECTED VOLTAGES OF 3-PHASES

SOURCE VOLTAGE OF 3-PHASES

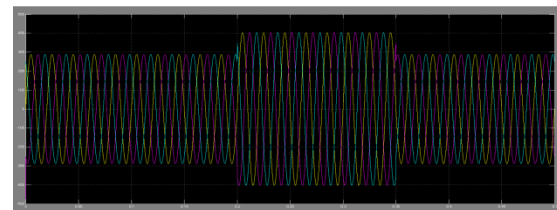

OBSERVED VOLTAGE OF 3-PHASES

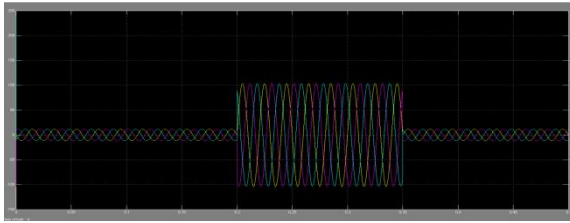

SOURCE VOLTAGES OF 3-PHASES

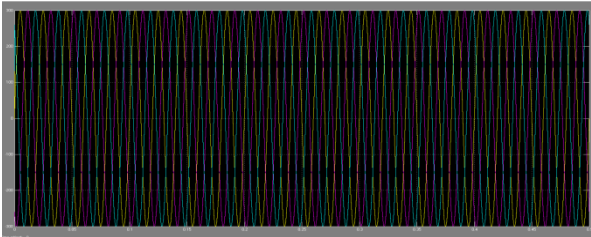

CONCLUSION&FUTURE SCOPE:

A new coordinated active power control strategy has been proposed to share the active power between the shunt and series converters of the UPQC for distributed generation applications. This proposed control strategy has been compared with the conventional control strategy of the UPQC by using PID controller results. The capability of sending the active power through the series converter has been demonstrated. This control algorithm reduces the burden on the shunt converter and also improves the reliability of the system.

FUTURE SCOPE: So far our researching at UPQC with BESS and in case of our proposed also we are utilizing the ultra-capacitor in future we can replace the ultra-capacitor by PV.

REFERENCES

[1] S. Chowdhury, S. P. Chowdhury and P. Crossley, Micro grids and Active

Distribution Networks, London, United Kingdom, The Institution of Engineering and Technology, 2009.

[2] Suleiman M. Sharkh, Mohammad A. Abu-Sara, Georgios I. Orfanoudakis and Babar Hussain, Power Electronic Converters for Micro grids, New York, USA, Wiley-IEEE Press, 2014.

[3] M. I. Marei, E. F. El-Saadany and M. M. A. Salama, "Flexible distributed generation: (FDG)," in proc. IEEE Power Engineering Society Summer Meeting, vol. 1, 25 July 2002, pp. 49-53.

[4] T. Dragicic, J. C. Vasquez, J. M. Guerrero and D. Skrlec, "Advanced LVDC Electrical Power Architectures and Micro grids: A step toward a new generation of power distribution networks," IEEE Electrification Mag., vol. 2, no. 1, pp. 54-65, March 2014.

[5] J. F. G. Cobben, W. L. Kling and J. M. A. Myrzik, "Power quality aspects of a future micro grid," in Proc. Int. Conf. on Future Power Syst., 2005, 18 Nov. 2005, pp. 1-5.

[6] T. Keil, J. Jager, A. Shustov and T. Degner, "Changing network conditions due to distributed generation - systematic review and analysis of their impacts on protection, control and communication systems," in Proc. 19th Int. Conf. on Electricity Dist., Vienna, Austria, May 2007.

Author Profile:



T.Samatha, PG scholar: Dept. of EPS, Joginapally Bhaskar Institute of Engineering & Technology, Hyderabad. I completed my Diploma (EEE) in 2012 at Govt polytechnic College and I completed my B.Tech (2015) in PRRMEC affiliated to jntuh, presently perusing M.Tech in JBIET, interested area in electrical power system & power electronics.

Email ID: tippanisamatha@gmail.com

Author Profile:



G.Upendra Rao, Assistant Professor: Dept. of EPS, Joginapally Bhaskar Institute of Engineering & Technology, Hyderabad. He completed B.Tech at JNTU in 2003 and he completed M.Tech at JNTU Anantapur. His area of Research interest is Power System. He pursuing PH.D in JNTU-Hyderabad

Email ID: upender229@gmail.com