

Dominion Systematized Association New Routing Path Using BFS Algorithm

Salini Lingineni¹, D.Kumar²

¹PG Scholar Department of CSE, Dr.Samuel George Institute of Engineering & Technology,
Markapur, Prakasam(D.T),Andhra Pradesh

²Associate Professor,Department of CSE, Dr.Samuel George Institute of Engineering &
Technology, Markapur, Prakasam(D.T),Andhra Pradesh

Abstract: In Wireless Sensor Networks (WSN), energy is a very precious resource for sensor nodes and communication overhead is to be minimized. These sensor nodes encompass limitations such as power, memory and computational capability. Since medium Access Control sub layer controls transmissions of the media and collisions, it has significant impact in reducing energy consumption and increasing the channel's efficiency. This paper proposes a new routing protocol based on BFS algorithm. Simulation Results show that the proposed protocol is efficient in terms of reducing energy consumption and increase the WSNs lifespan and achieves better performance than well-known protocols in terms of transmission delay, throughput, and packet delivery ratio. We propose an energy efficient adaptive multipath routing technique which utilizes multiple paths between source and the sink, adaptive because they have low routing overhead. Methods used recentralized heuristic and ant colony gossiping to find best energy efficient path. CAS (Cooperation-Aware Scheme) is used to reduce the traffic in the network. This work makes use of an extended Greedy Perimeter Stateless Routing (eGPSR) protocol that mainly focuses on energy efficient data transmission. The proposed approach can significantly reduce collision, sleep-delay and idle listening. Computer simulation approach is used to evaluate the proposed algorithm. This data transmission is based on the fact that the message that is sent to a distant node consumes more energy than the message that is sent to a short range transmission. The proposed routing technique achieves in terms of End-to-End Delay, Throughput, Portion of Living Node (PLN) and Network Lifetime. The experimental result shows that the use of eGPSR in routing has improved throughput with comparatively less delay.

Index Terms: Centralized heuristic, Cooperation-Aware Scheme, multipath routing, routing, sensor networks, Medium Access Control, Wireless Sensor Network, Portion of Living Node (PLN) and Network Lifetime

1. INTRODUCTION

Wireless Sensor Networks (WSNs) are an ensemble of Micro-sensor nodes that have economical processing, storing capability and radio technologies with macro-sensors

micro sensor nodes are less effective but they still produce fail-safe and extremely good sensor networks by using thousands of sensors within a network area [1]. Energy consumption of each sensor node during the routing process in wireless sensor network considered as the most common problem in

this type of systems, and reliability, so that, find a solution to this problem is a big challenge [2]. They create a demand for energy-efficient and robust protocol designs with specific consideration of the unique features of sensor networks, such as data-centric naming and addressing convention, high network density and power limitation [3]. So introduce both centralized heuristic search and a distributed heuristic based on ant colony gossiping, to obtain approximate solutions. Our algorithm designs also take into account load balancing of individual nodes to maximize the system lifetime [4]. Data Centric routing protocols are used to manage the redundancy of data, it happens for the reason that sensor nodes do not have global identification which identifies them uniquely [5]. The estimation of location-based protocols is using an arena instead of a node identifier as the object of a packet positions within the given area will be acceptable as a destination node and can obtain and process a message [6].

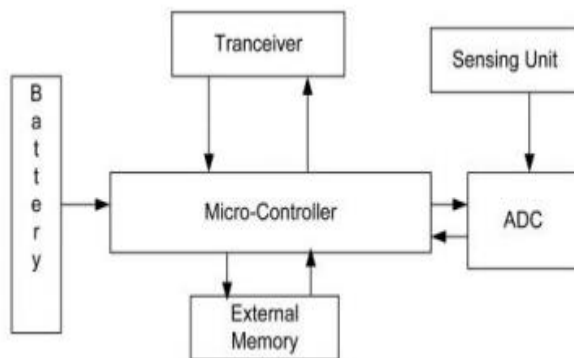

Figure 1. Sensor Node Architecture

2. RELATED WORK

In recently proposed algorithms are described and reviewed point, S-MAC protocol is one of common active-period protocols. It is used in several ways for reducing energy consumption, overhead and controlling delay. Also, it is used for

periodic listening in which listening and sleeping durations are fixed [7]. The practical procedure to find this route in this paper is based on select function with Best First Search (BFS) algorithm which means that any sensor node wants to pass data to next node must take into consideration this heuristic which is; straight line distance (SLD) from any sensor node to the sink node, the residual energy for this node, and also the minimum amount of the energy that must be held by this node to be in the path, this technique will save the energy for all sensor nodes in the network, which in turn will increase the WSN lifetime and reliability [8]. The proposed protocols that use multiple paths choose the network reliability as their design priority proposed an algorithm which will route data through a path whose nodes have the largest residual energy [9]. Compressive sensing and particle swarm optimization algorithms to build up data aggregation trees and decrease communication rate different from EDAL in that they require all nodes to contribute sensing data during the data collection phase [10]. The greedy forwarding method makes decision using information about the immediate neighbors of router that is taken into account the routes are identified along the perimeter of a region [11].

3. SYSTEM MODEL

Key motivation for this work stems from the insight that recent research efforts on open vehicle routing (OVR) problems are usually based on similar assumptions and constraints compared to sensor networks research on goods transportation the objective is to spread the goods to customers in finite time with the minimal amount of transportation cost [12]. It allows the modification that is a critical aspect of maintainability of software and leads to

simpler implementation through the encouragement of the parallel development of the various parts of system [13]. In network topology, the greedy forwarding mechanism takes routing decisions based on the information only about directly connected neighbors. Load balancing is especially useful in energy constrained networks because the relative energy level of the nodes does affect the network lifetime more than their absolute energy level [14].

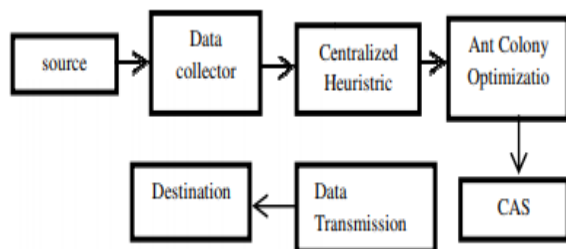

Figure 2 System Architecture

4. PROPOSED METHOD

Power and delay aware relay-node selection algorithm is proposed for cluster based MWSN. Initially the transmitted data packets are assigned priorities as follows: For collected data of its own, the priority is 1. For collected packets from other nodes, the priority is 2 [15]. Sequential Assignment Routing (SAR) was proposed as new routing protocol that is a concern in routing protocols that support some quality of service. The sensor nodes are getting connected to internet nowadays. Internet of Things (IoT) requires the sensor data to be transmitted in a secure manner where it expects higher security levels [16]. The routes are identified along the perimeter of a region when a greedy node fails to find a path towards destination. GPSR is the extension of GPSR protocol where the next node is chosen based on the energy levels [17].

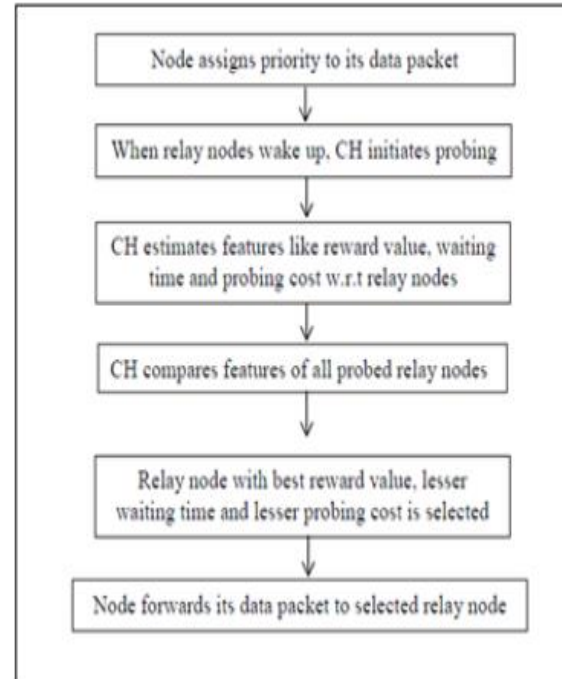

Figure 3 Block Diagram of Proposed Technique

1. Aware-Routing Protocol Best First Search algorithm

In wireless sensor network routing protocols classified into three approaches of routing protocols, which are hierarchical-based routing protocol, location-based routing protocol, and flat-based routing protocol. In this paper the proposed Aware-Routing protocol based on Best First Search algorithm will be considered in flat-based approach, because it is more suitable than other routing protocols for the proposed topology and structure, especially for particular applications such as event detection [18].

Step 1: The Straight Line Distance (SLD) which is the straight distance from the current node to the base station (sink node), also, SLD is previously known, fixed value, and describes the node value

Step 2: The amount of energy at each sensor node, this values updated frequently from the base station, which means that weak nodes will not participate in path to avoid link break, and finally the threshold for the minimum amount of energy that must be available for each sensor node to be included in the path.

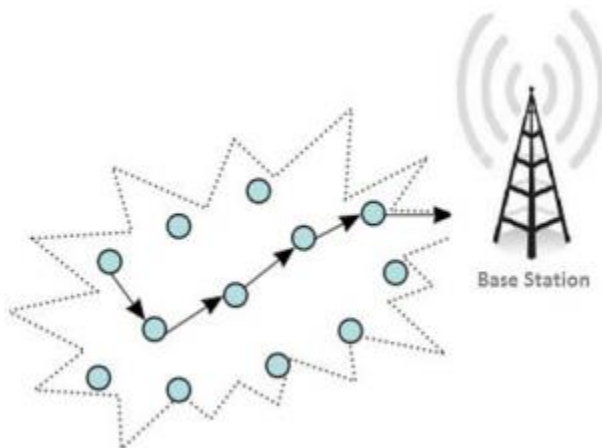

Figure 4. Multi-Hop Communication Path.

5. MULTIPATH ROUTING SCHEME

The sensor nodes are distributed randomly in the sensing field. A network composed of a sink node and many wireless sensor nodes in an interesting area is considered all nodes in the network are assigned with a unique ID and all nodes are participating in the network and forward the given data [19]. The protocol replies with multiple routes from the source node to the sink quickly, and prepares the paths that efficiently balance the energy of the nodes. Each node maintains a neighbor table for the routing protocol to function. The neighbor table contains an entry of all the selected neighboring nodes through which a node can transmit data [20].

A. Multipath Routing:

The multi-path routing models the sensor network into levels according to the hop distance from the sink node to a source node. A node is in level L, if it is L hops apart from the sink. The sink is a level 0 node. All nodes that can talk directly with at least one level N node but cannot talk directly with any level N-1 nodes are defined as level N+ 1 node. Thus, level N nodes have path length of N hops back to the sink. Data Transmission Phase by using two messages namely route request message and route reply message. Route Request message is transmitted when a node enters in the network to execute the neighbor discovery process [21].

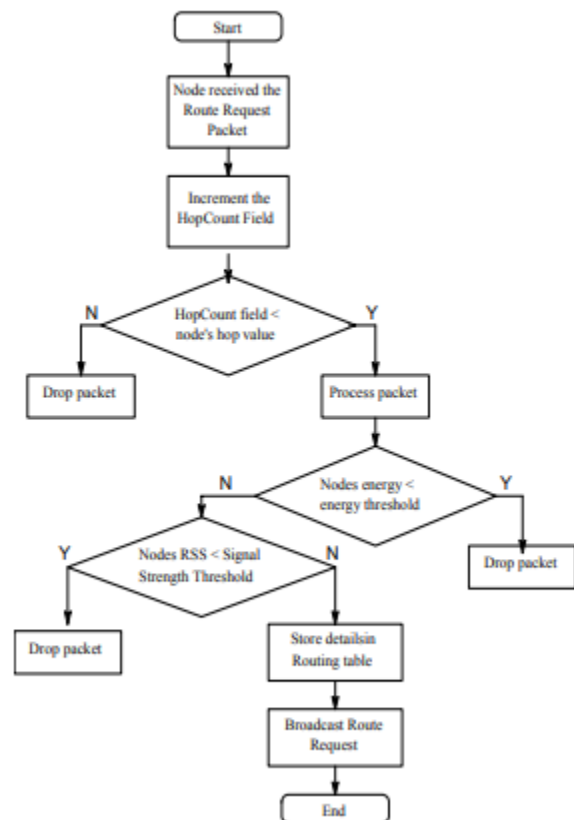

Fig 5: Multipath Routing Phase

B. Multipath Construction Phase

The sink node starts the multipath path construction phase to create a set of neighbors that is the address of all nodes that are able to transmit data from the source. During this process route request messages are exchanged between the nodes [22]. Furthermore, it supports multipath data forwarding, not using the fixed path. So the energy consumption will be distributed and the lifetime of network is prolonged. The Source ID contains the node ID of the message destination; Seq Number field is a packet sequence. The Hop Count field is the number of hops from the sink node which is used to identify nodes in different levels, nodes that can receive the radio signal of sink are defined as one-hop / level 1 nodes, Energy threshold field provides the minimum required energy level for a node to be selected for data transmission, Signal Strength threshold to indicate the minimum distance the node has to be located in order to receive all the data's transmitted to that node and Sink ID indicates the ID of the sink which broadcasts the route request packet [23]. The major activities in this phase are routing path formation for each node and neighbor table creation. The sink node broadcasts the route request packet to discover the one hop nodes / level 1 nodes, the nodes which are receiving them first.

Source ID	SeqNumber	HopCount	Energy Threshold	SignalStrength Threshold
-----------	-----------	----------	------------------	--------------------------

Fig 6: Route Request Message frame format

6. PERFORMANCE ANALYSIS

We simulate energy efficient adaptive multipath routing scalable discrete-event simulator developed software provides a high fidelity simulation for wireless communication with detailed propagation, radio and MAC layers. We compare energy

efficient routing with two popular sensor networks routing protocols – directed diffusion and flooding the bench mark scheme. Clear To-Send (CTS) control packets to provide virtual carrier sensing for unicast data packets to overcome the well known hidden terminal problem. Each data transmission is followed by ACK. Sensor nodes around 100 are uniformly distributed over a 1000m×1000m area. For all traffic conditions multipath routing exhibits less than two-third the data latency of flooding, this is due to the fact that the route selection is more optimized by choosing shortest multi paths against the longer paths. Our results show that energy efficient algorithm can decrease the energy expense of communication with minimum tradeoffs in quality of service.

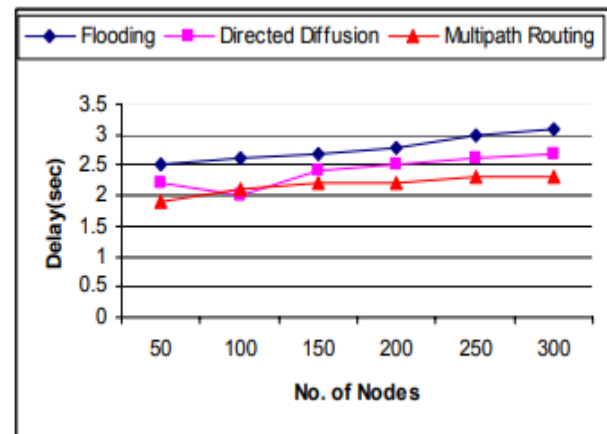

Fig 7: Average Data Packet Delivery Delay

7. CONCLUSIONS AND FUTURE WORK

This paper proposed an Aware-Routing protocol based on Best First Search algorithm; this protocol used the multivariable heuristic function in the process of selecting the next hop communication path. AR-BFS computes an optimized route to transmit the packets from any sensor node in the network to the base

station. The adaptive multipath routing protocol is capable to search multiple paths and aims to allocate the traffic rate to each path optimally proposed scheme has higher node energy efficiency than the directed diffusion, and flooding. The centralized heuristic algorithm generates routes that connect all nodes with minimal total path cost, under the constraints of packet delay requirements. Energy efficiency of the newly encountered nodes is the main emphasis of the proposed protocol. Since each neighbor node is constantly decreasing the energy due to the sensing activity, the node with high energy level is chosen as the neighbor node. Thus a reliable and energy efficient communication is enabled in the network leading to improved throughput and reduced delay. In the future work, other artificial intelligence algorithms will be tested like: A* or Knapsack to test the system performance. The protocol can be used for securing the aggregated data transmission over IoT. The protocol can be enhanced further to provide robust secure communication.

8. REFERENCES

- [1] A. A. Kumar S., K. Øvsthus, and L. M. Kristensen, "An industrial perspective on wireless sensor networks—A survey of requirements, protocols, and challenges," *IEEE Commun. Surveys Tuts.*, vol. 16, no. 3, pp. 1391–1412, 3rd Quart., 2014.
- [2]. ArjanDurreesi and et.al., "Delay-Energy Aware Routing Protocol for Sensor and Actor Networks", *Proceedings of the 2005 11th IEEE International Conference on Parallel and Distributed Systems (ICPADS'05)*, 2005
- [3]. Liming He, "Delay-Minimum Energy-Aware Routing Protocol (DERP) for Wireless Sensor Networks", *IEEE Eighth ACIS International Conference on Software Engineering, Artificial Intelligence, Networking, and Parallel/Distributed Computing*, 2007.
- [4]. D. Estrin, R. Govindan, J. Heidemann, and S. Kumar, "Next Century Challenges: Scalable Coordination in Sensor Networks," *Proc. ACM/IEEE MobiCom*, pp. 263-270, 1999.
- [5]. X. Wu and G. Chen, and S.K. Das, "Avoiding Energy Holes in Wireless Sensor Networks with Nonuniform Node Distribution," vol. 19, no. 5, pp. 710-720, 2008.
- [6]. Y. Xu, J. Heidemann, and D. Estrin, "Geography-Informed Energy Conservation for Ad-Hoc Routing," *Proc. ACM MobiCom*, 2001
- [7] Hussein A. and Samara G., "Coordinator Location Effects in AODV Routing Protocol in ZigBee Mesh Network," *International Journal of Computer Application*, vol. 127, no. 8, pp. 975- 8887, 2015.
- [8] Kiani F., Amiri E., Zamani M., Khodadadi T., and Abdul Manaf A., "Efficient Intelligent Energy Routing Protocol in Wireless Sensor Networks," *International Journal Distributed Sensor Networks*, vol. 11, no. 3, 2015.
- [9] Kiani F., "AR-RBFS: Aware-Routing Protocol Based on Recursive Best-First Search Algorithm for Wireless Sensor Networks," *Journal of Sensors*, vol. 2016, pp. 1-10, 2016.
- [10] Kumar A., Ovsthus K., and Kristensen L., "An Industrial Perspective on Wireless Sensor Networks-A Survey of Requirements, Protocols, and Challenges," *IEEE Communications Surveys and*

Tutorials, vol. 16, no. 3, pp. 1391-1412, 2014.

[11] Lin H. and Uster H., "Exact and Heuristic Algorithms for Data-Gathering Cluster-Based Wireless Sensor Network Design Problem," IEEE/ACM Transactions on Networking, vol. 22, no. 3, pp. 903-916, 2014.

[12] Luo J., Hu J., Wu D., and Li R., "Opportunistic Routing Algorithm for Relay Node Selection in Wireless Sensor Networks," IEEE Transactions on Industrial Informatics, vol. 11, no. 1, pp. 112- 121, 2015.

[13] Maheen N., "Efficient, Least Cost, EnergyAware (ELCEA) Quality of Service Protocol in Wireless Sensor Networks," International Journal of Science and Research, vol. 3, no. 6, pp. 442-448, 2014.

[14] Majumdar S., Pattanaik M., and Alamelu J., "Energy Efficient Wireless Sensor Network For Polyhouse Monitoring," European Journal of Advances in Engineering and Technology, vol. 2, no. 6, pp. 77-82, 2015.

[15] Jian Wu, Stefan Dulman, and Paul Havinga "ReliableSplitted Multipath Routing for Wireless Sensor Networks" Proceedings of Building Intelligent Sensor Networks (BISON 04), China 2004

[16] A. Nasipuri and S. Das, "On-demand multipath routing for mobile ad hoc networks," in Proc. of International Conference on Computer Communications and Networks (IC3N), Boston, MA, USA, Oct. 1999.

[17] M. Marina and S. Das, "On-demand multipath distance vector routing in ad hoc networks," in Proc. of the Ninth International Conference for Network

Protocols (ICNP), Riverside, CA, USA, Nov. 2001.

[18] C. Barrett, S. Eidenbenz, L. Kroc, M. Marathe, and J. Smith, "Parametric probabilistic sensor network routing," in Proc. of ACM WSNA'03, San Diego, CA, Sept. 2003, pp. 122–131.

[19] P. Raghu Vamsiand Krishna Kant, "An Improved Trusted Greedy Perimeter Stateless Routing for Wireless Sensor Networks," I.J. Computer Network and Information Security, vol 11, pp. 13-19 Oct. 2014.

[20] Mayank Sharma, Yashwant Singh and Nagesh Kumar, "Opportunistic Routing in Wireless Sensor Networks: A Comparative Analysis," J. Basic and Applied Engineering Research, vol. 1(6),pp. 94-98,Oct. 2014.

[21] Geetha R and Nivedha R, "Survey on various clustering algorithms and parameters," SSRG I.J. Electronics and Communication Engineering - (2'ICEIS – 2017) - Special Issue – April 2017.

[22] JunqiDuan, Dong Yang, Haoqing Zhu, Sidong Zhang, and Jing Zhao, "TSRF: A Trust-Aware Secure Routing Framework in Wireless Sensor Networks," I. J. of Distributed Sensor Networks vol. 6, 2014.

[23] Liu L, Zhang X. and Ma H. (2010), „Optimal node selection for target localization in wireless camera sensor networks“, IEEE Trans. Veh.Technol., vol. 59, No. 7, pp. 3562–3576.

Student details:

Name: Salini Lingineni

Dr.Samuel George Institute of Engineering & Technology, Markapur, India, AP

Mail id: talasilalingineni@gmail.com



Guide details:

D.Kumar received B.Tech (CSIT) Degree from JNT University in 2006 and M.Tech (CSE) Degree from JNTUK Kakinada in 2011. He has 11 years of teaching experience. He joined as Assistant Professor in Dr.Samuel George Institute of Engineering & Technology, Markapur, India in 2006. Presently he is working as Associate Professor in CSE Dept. His Interested research areas are Image Processing and Computer Networks. He attended Various National and International Workshops and Conferences.