

Efficient Solar Water Pumping System Using Maximum Power Point Tracking (MPPT)

D.Srilaxmi & M.Arun kumar

¹Assistant Proffesor, ²PG scholar

Dept. of E&I, Vallurupalli Nageswara Rao Vignana Jyothi Institute of Engineering &Technology,
Hyderabad -500090, Telangana, India.

Abstract - A simple and efficient solar water pumping system utilizing an induction motor drive (IMD) is presented in this paper. This solar water pumping system comprises two stages of power conversion. The first stage extracts the maximum power from a solar PV array by controlling the duty ratio of a dc-dc boost converter. The dc bus voltage is maintained by the controlling the motor speed. This regulation helps in the reduction of motor losses by reducing motor currents at higher voltage for the same power injection. To control the duty ratio, an incremental conductance based maximum power point tracking (MPPT) control technique is utilized. The proposed system is modelled, and its performance is simulated in detail. The scalar control eliminates the requirement of a speed sensor/encoder. Consequently, the need of motor current sensor is also eliminated. Moreover, the dynamics are improved by an additional speed feed forward term in the control scheme. The proposed control scheme makes the system inherently immune to the variation in the pump constant. The prototype of PV- powered IMD emulating the pump characteristics is developed. In the laboratory to examine the performance under different operating conditions

Keywords -Photovoltaic cells,(MPPT)maximum power point tracking, water pumping, scalar control,(IMD) induction motor drives

I. INTRODUCTION

Solar photovoltaic is the field of technology and research related to the devices which directly convert sunlight into electricity. The solar cell is the elementary building block of the photovoltaic technology. Solar cells are made of semiconductor materials, such as silicon. One of the properties of semiconductors that makes them most useful is that their conductivity may easily be modified by introducing impurities into their crystal lattice. For instance, in the fabrication of a photovoltaic solar cell, silicon, which has four valence electrons, is treated to increase its conductivity. On one side of the cell, the impurities, which are phosphorus atoms with five valence electrons (n-donor), donate weakly bound valence electrons to the silicon material, creating excess negative charge carriers. On the other side, atoms of boron with three valence electrons (p- donor) create a greater affinity than silicon to attract electrons. Because the p-type silicon is in intimate contact

with the n-type silicon a p-n junction is established and a diffusion of electrons occurs from the region of high electron concentration (the n-type side) into the region of low electron concentration (p-type side). When the electrons diffuse across the p-n junction, they recombine with holes on the p-type side. However, the diffusion of carriers does not occur indefinitely, because the imbalance of charge immediately on either sides of the junction originates an electric field. This electric field forms a diode that promotes current to flow in only one direction. Ohmic metal- semiconductor contacts are made to both the n-type and p-type sides of the solar cell, and the electrodes are ready to be connected to an external load.

II. SOLAR WATER SYSTEM

In Solar water systems, an induction motor drive (IMD) shows good performance as compared to other commercial motors because of its rugged construction. The evolution is intended to develop productive, reliable, maintenance-free and cheap solar water pumping system. However; new permanent magnet motors such as brushless DC motor and permanent magnet sine fed motors are used into pumping, but are still overshadowed by induction motor because of cost and availability constraint. Moreover, the manufacturing of the induction motor is in matured stage giving an edge to its use in developing countries for solar water pumping application. With the emergence of outperforming solid state switches, high speed processors and Efficient motor control algorithms, IMD based water pumping systems have taken a step ahead to conventional water pumping systems. Moreover, PV array fed IMD has performed ruggedly in the field of pumping system by utilizing a VSI (Voltage Source Inverter). The proposed work deals with a three-phase IMD for solar water pumping, which meets the requirement of life without electricity in remote locations. The initial cost of solar power plant is high. Therefore, once the plant is installed, the focus is to obtain the peak power from the solar panels of the installed capacity. The developed water pumping system powered directly from PV array requires MPPT algorithms to operate under different irradiation levels and to extract the peak power from a solar PV array. Some of these, MPPT algorithms are recommended. A comparative study on different MPPT techniques is provided. From operational point of view, MPPT is a mandatory segment of a PV system. The substantial research is reported in past few years in the area of MPPT. In this paper, an INC

(Incremental Conductance) based technique is used to obtain the peak power from the solar PV array. Therefore, the proposed PV fed water pumping system produces peak torque even at low radiation. The INC technique is based on the comparison of output conductance of solar PV array to the incremental conductance. As compared to solar PV grid interfaced systems [5], the major challenge in PV water pumping is timely control of active power.

III. INDUCTION MOTOR

An induction motor or asynchronous motor is a type of alternating current (AC) electrical motor that uses the principles of induction motors to produce power. Induction motors operate by mechanically turning their rotors faster than synchronous speed. A regular AC asynchronous motor usually can be used as a motor, without any internal modifications. Induction motors are useful in applications such as mini hydro power plants, wind turbines, or in reducing high-pressure gas streams to lower pressure, because they can recover energy with relatively simple controls. An induction motor usually draws its excitation power from an electrical grid; sometimes, however, they are self-excited by using phase-correcting capacitors. An induction motor produces electrical power when its rotor is turned faster than the synchronous speed. For a typical four-pole motor (two pairs of poles on stator) operating on a 60 Hz electrical grid, the synchronous speed is 1800 rotations per minute (rpm). The same four-pole motor operating on a 50 Hz grid will have a synchronous speed of 1500 RPM.

IV. SIMULATION WORK

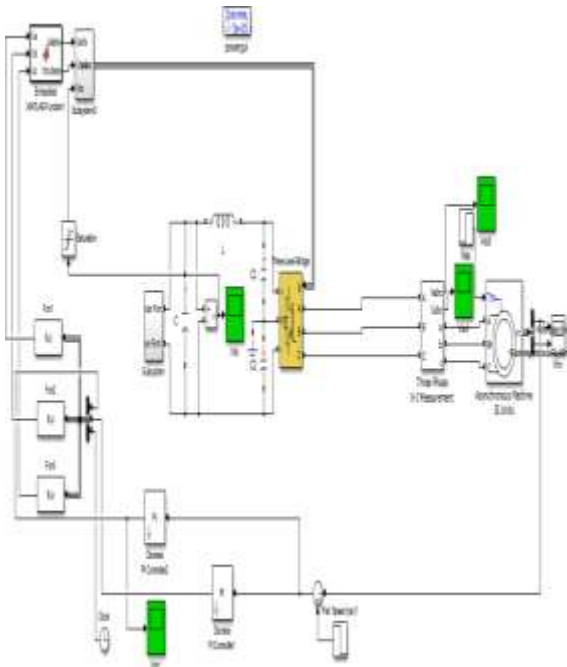

Figure 1

Solar m

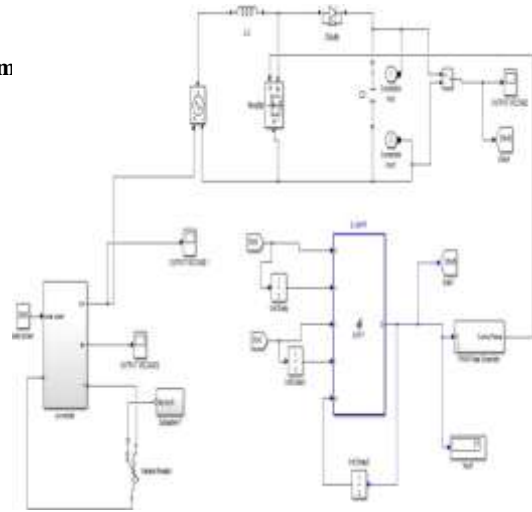

Figure 2

Solar Cell

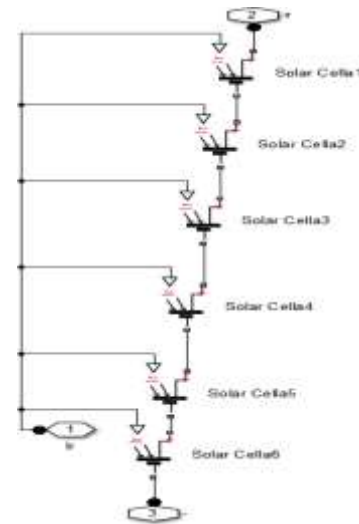
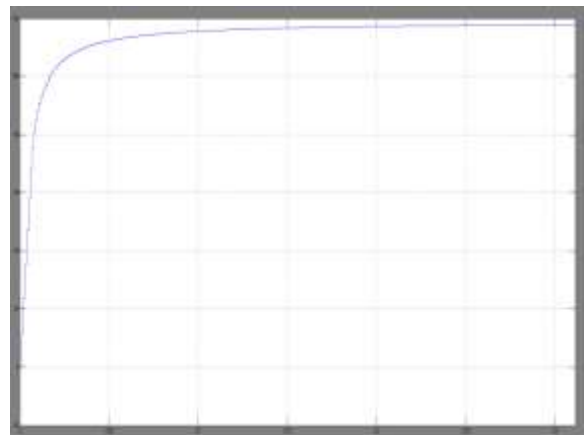

Figure 3

Solar Input

V. WAVEFORMS



Boost output

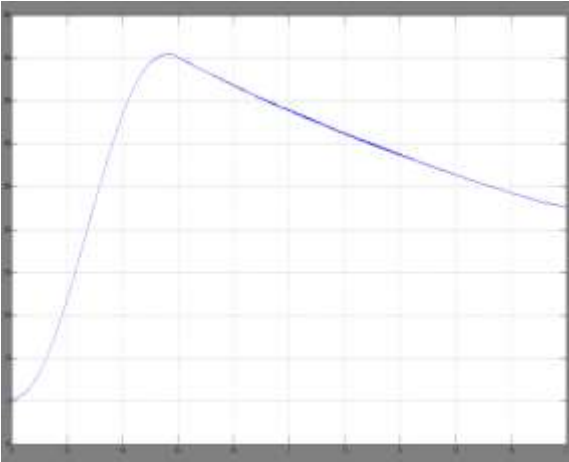

Figure 4

Electromagnetic torque

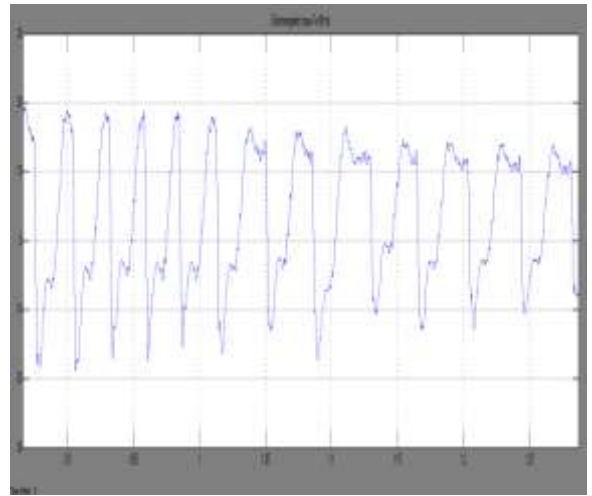
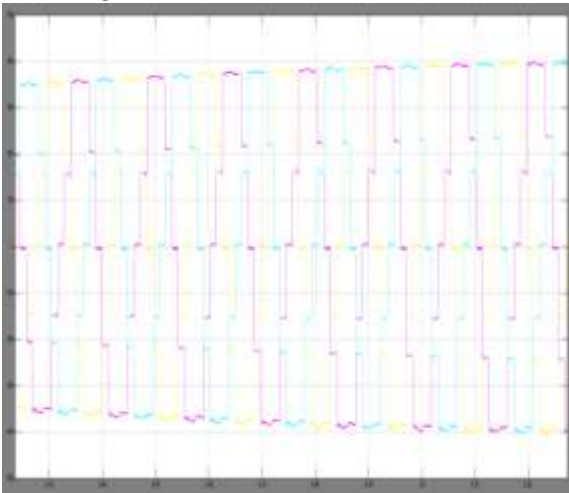

Figure 9

Inverter voltage



Inverter current

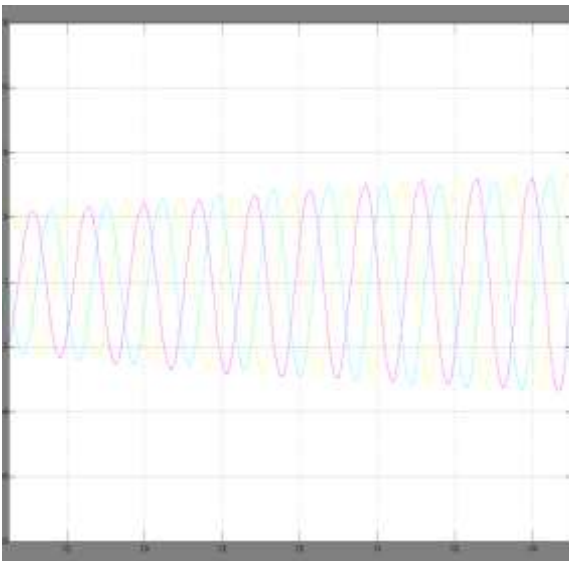
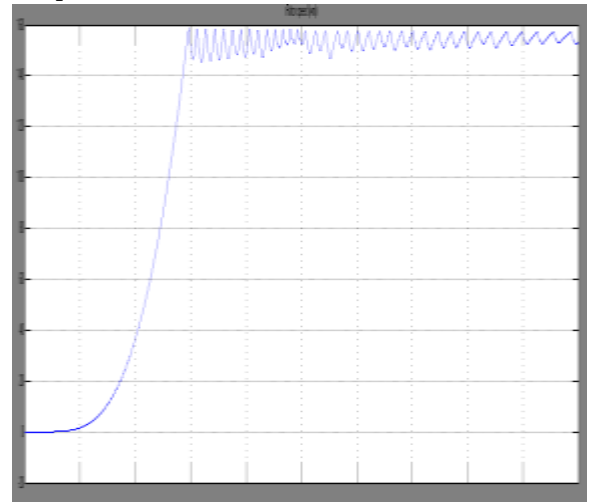

Figure 7

Motor speed



Hardware Output:

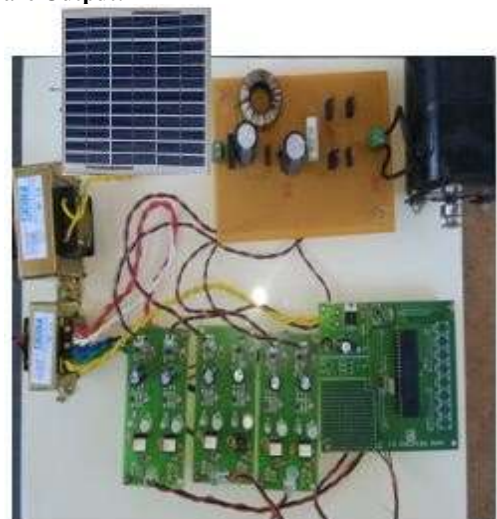

Figure 9

VI. CONCLUSION

In this paper solar water Pumping system using Induction motor has proposed , by reducing the use of sensor. Designed simulation is executed using simlink/Matlab Software. This method used the MMPT (maximum power point tracking system) to obtain a maximum energy from solar panel , and further different techniques are used to increase the voltage like boost converter. The reference speed generation for voltage-frequency management them has been planned supported the obtainable power the regulation the active power at DC bus. Its feasibility of operation has been verified through simulation and experimental validation. Various performance conditions such as starting, variation in radiation and steady state have been experimentally verified and found to be satisfactory.

VII. REFERENCES

- [1]. E. Drury, T. Jenkins, D. Jordan, and R. Margolis, "Photovoltaic investment risk and uncertainty for residential customers," *IEEE J. Photovoltaics*, vol. 4, no. 1, pp. 278–284, Jan. 2014.
- [2]. E. Muljadi, "PV water pumping with a peak-power tracker using a simple six-step square-wave inverter," *IEEE Trans. on Ind. Appl.*, vol.33, no. 3, pp. 714-721, May-Jun 1997.
- [3]. U. Sharma, S. Kumar and B. Singh, "Solar array fed water pumping system using induction motor drive," 1st IEEE Intern. Conf. on Power Electronics, Intelligent Control and Energy Systems (ICPEICES), Delhi, 2016.
- [4]. T. Franklin, J. Cerqueira and E. de Santana, "Fuzzy and PI controllers in pumping water system using photovoltaic electric generation," *IEEE Trans. Latin America*, vol. 12, no. 6, pp. 1049-1054, Sept. 2014.
- [5]. R. Kumar and B. Singh, "BLDC Motor-Driven Solar PV Array-Fed Water Pumping System Employing Zeta Converter," *IEEE Trans. Ind. Appl.*, vol. 52, no. 3, pp. 2315- 2322, May-June 2016.
- [6]. S. Jain, A. K. Thopukara, R. Karampuri and V. T. Somasekhar, "A Single-Stage Photovoltaic System for a Dual-Inverter-Fed Open-End Winding Induction Motor Drive for Pumping Applications," *IEEE Trans. Power Elect.* vol. 30, no. 9, pp. 4809-4818, Sept. 2015.

Author Profile:



D.Srilaxmi, Assistant Professor: Dept. of E&I, Vallurupalli Nageswara Rao Vignana Jyothi Institute of Engineering & Technology, Hyderabad. She completed M.Tech in SRM University, Chennai. She has teaching experience of 12 years. Her area of Research interest is Image processing

Author Profile:



M.Arun Kumar, PG scholar: Dept. of E&I, Vallurupalli Nageswara Rao Vignana Jyothi Institute of Engineering & Technology, Hyderabad. I completed my B.tech 2017 in DVR CET affiliated to jntuh, presently perusing M.Tech in VNR VJIEET , interested area in electrical applications