

## Studying The Process Of Preparing Polimer Details Under Pressure Used In Modern Motor Vehicles

<sup>1</sup>Sh.A. Turaev, <sup>2</sup>Irgasheva Nasiba Dadajonovna

<sup>1</sup>Assistant teacher of the department of "Land transport systems",

<sup>2</sup>Senior Lecturer of the Department of Languages,

Andijan Machine - Building Institute

**Abstract:** *The article deals with the method of studying of modes of manufacturing of automobile details under pressure.*

**Keywords:** *a polymeric material, the material expense, moulding under pressure, the press form, the foundry car, a polymeric composition.*

The purpose of the work is to study the modes of manufacturing a car detail from local polymeric materials.

Polymeric materials can be plastic deformed by heating and pressure to take a particular shape and remain stable. Plasticity is the ability of the polymer to obtain and retain the required forms, is a special feature of the polymer. Their usage is economically advantageous because the characteristics to done around their materials, the cost of manufacturing the details are reduced and the details become much lighter, and the capital and operating costs will be more reduced.

It is known that [1-2], the waste of polymeric material does not exceed 5-10%, and in metal making 60-70%. Products made of polymeric material have lower friction and ease than metal ones. The cost is also two or three times cheaper than metal.

The diagram of the pressure injection equipment from polymeric materials is shown in Figure 1. Pressure casting machine consists of rod 1, piston 2, cylinder 3, nozzle 4 and press mold 5.

Into the loading bunker of the Foundry will be added (1) 600-650 g of polymer composition. The polymer composition is transferred to the material cylinder of the foundry (3) and heated to 240-270<sup>0</sup> C for 30-40 minutes. Heat parts (4) to 240<sup>0</sup> C are initially installed on a board (5), which heated up to 80-100<sup>0</sup>C.

As the piston of the foundry is moved from left to right, the compressed polymer composite cylinder is removed from the cylinder and filled with traction from the surface of the molded detail. The temperature of the liquid composition should be 20<sup>0</sup> C above from its liquid temperature, the specific pressure should be 30-35 MPa, and the time under pressure is 20 hours. Then the pressure is lowered and the press form is separated. The restored detail is removed, the stitches are cleaned, the excess pieces of material are removed, and will be given thermal treatment at a temperature of 120<sup>0</sup>-130<sup>0</sup> C for 1.5-2 hours. Then, the detail is cooled together with oil to 111<sup>0</sup>C and cooled up to room temperature. When pouring polymers are under pressure, it should be checked 24 hours later.

In the method of pouring details under pressure, the efficiency of the work is high and it is possible to create the dimensions specified in the task without further elaboration of details.

The need to make a separate press form for each detail and the poor adhesion of the polymer layer to the surface of the details is a disadvantage of this method. Pressure retention time and template heating temperature are of great importance in the manufacture of motor vehicle parts under pressure from polymeric materials. The results of the experiment are presented in Figure 2-3. Polymers with different properties and types and different properties were used in the experiments. Figure 2 shows the dependence of the retention time of the polymer materials on printing. An analysis of the graph shows that as the retention time increases, the strength of pressure is also increases. Though, while its volume becomes more than 15-20 seconds, the cost of loading decreases.

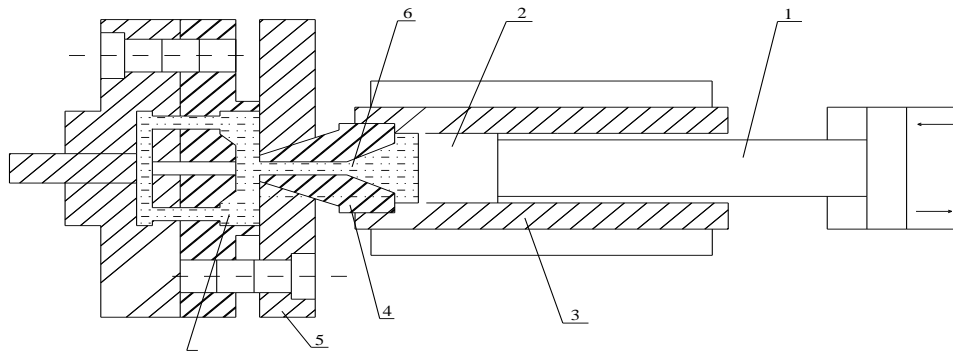

**Figure 1. Scheme of equipment pouring details under pressure.**

1- rod, 2-piston, 3-cylinder, 4-nozzle, 5-press form, 6-liquid polymer, 7-detail

The highest loading was observed in polyamide, and the lowest - in polyethylene. The physico-mechanical properties of these materials depend on their structure. The result is that pouring polyethylene into a mold under pressure among polymer materials is better than other polymers, which does not require much effort.

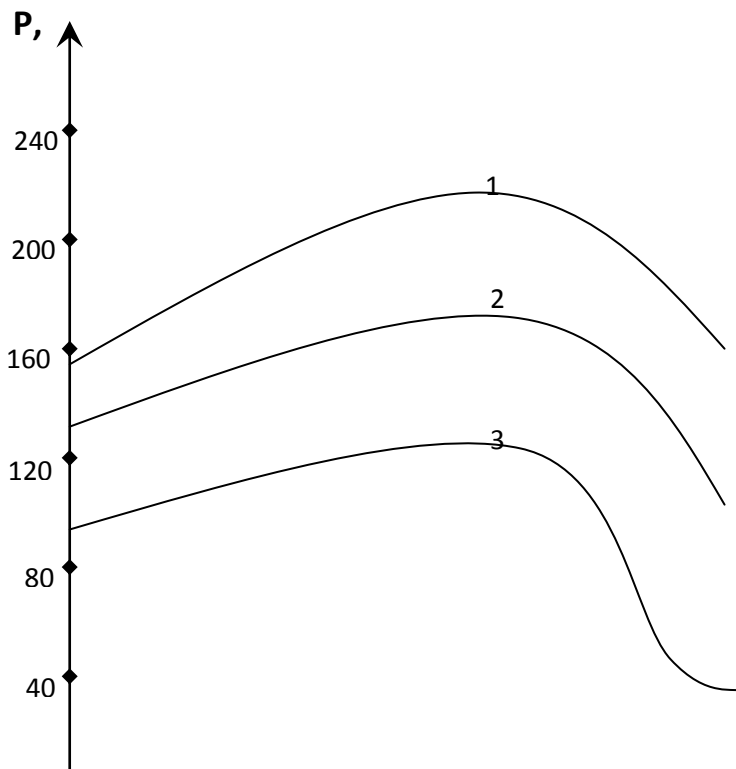

**Figure 2 Dependence of the retention time on the pouring polymeric materials under presse**

1- Polyamide, 2- Polypropylene, 3- Polyethylene.

Figure 3 illustrates dependence of the temperature of the mold heating on the heat load comparative loading of polymer materials under pressure. As it can be seen from the picture, the relative loading increases with increasing temperature of the mold heating. However, the value of the specific load decreases when the mold temperature drops below 60-70 degrees. This is due to the different physico-mechanical properties of polymer materials relative to temperature. In other words, As the temperature of the mold increases, the polymeric material is well poured into the mold, thus filling the mold and foundry quality will be good.

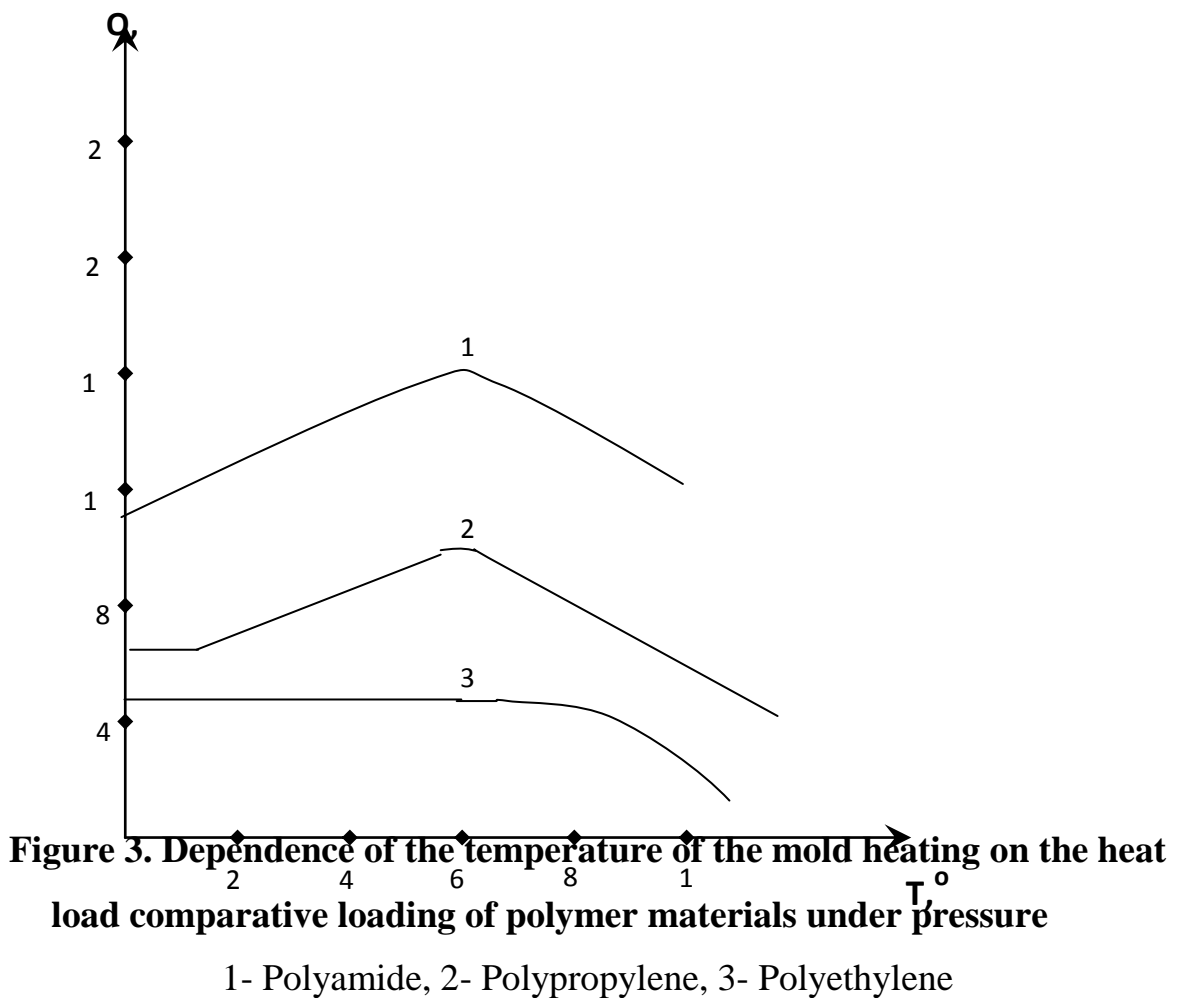

As the mold temperature drops, the polymer material becomes thicker while pouring and as a result, the mold cavity does not fill well and the casting quality becomes poor. Among the polymers seen in the experiment, the best result was in the polyethylene.

As a conclusion we can say that, in the process of pouring under pressure, the highest loading value was observed in polyamide and the lowest was obtained in polyethylene. Among the polymer materials, polyethylene molding is better than others, it does not need much force.

That is, as the temperature of the mold increases, the polymeric materials are poured well into the mold, and the lowering of the mold temperature causes the polymer material to be poured into it. Polyethylene showed the best result among polymers.

### **References**

1. Ikramov U.A. Fundamentals of Tribonics. -T .: Teacher, 2001, P. 430.
2. Handbook of composite material in 2 books, ed. Lubani D. Per with English Haller A.B., Helmont M.M. - M.: Mashinostroenie, 1998. P. 685