

## A review of Ocean thermal energy conversion technique and its Economical consideration

---

<sup>1</sup>Harish Kumar Patel; <sup>2</sup>Ajay Ram; <sup>3</sup>NiteshJatav & <sup>4</sup>MukeshXaxa,

<sup>1</sup>Lecturer & HOD Mechanical Department , Government Polytechnic Jashpur(c.g.)E-Mail-  
[harish.patelhydra@gmail.com](mailto:harish.patelhydra@gmail.com)

<sup>2</sup>Department of MechanicalEngg. (diploma), Government Polytechnic Jashpur(c.g.) [E-mail-ajaysinghrty@gmail.com](mailto:ajaysinghrty@gmail.com)

<sup>3</sup>Department of MechanicalEngg. (diploma), Government Polytechnic Jashpur(c.g.) [E-mail-jatavnitesh8@gmail.com](mailto:jatavnitesh8@gmail.com)

<sup>4</sup>Department of MechanicalEngg. (diploma), Government Polytechnic Jashpur(c.g.) [E-mail-mton528@gmail.com](mailto:mton528@gmail.com)

### ABSTRACT

*At present era of energy seeking prospectus the energy brought by any means are advantageous for life so Energy from our ocean and seas can be produced with broad range of technology. It can be done by use of wave, tidal, OTEC and osmotic energy here grouped under the term “ocean renewable energy “.in case of Ocean thermal energy conversion (OTEC) we utilize the temperature gradient between warm surface ocean water and the cold deep ocean water to generate electricity. This alternate energy source does not depend on fossil fuels and has less environmental impact than other energy sources.*

*This paper present different technique to generate electricity by OTEC. And various process involving Rankine process with main focus. The efficiency study by network output from the turbine shaft and temperature gradient and its economy.*

#### Keywords:

Renewable energy; Ocean thermal energy conversion(OTEC); Open cycle; Closed cycle; Hybrid cycle; Efficiency

### 1. Introduction

The energy requirement is higher at present days and it will increase day by day in future. To meet the requirement we use lots of fossil fuels, but that are limited and in future they will end up, so for concerning this facts we goes to utilize the renewable source of energy. There are large possibilities to use ocean energy for energy production.

The Oceans cover more than 70% of the earth's surface. This makes them the largest solarenergy collector and energy storage system on this planet. The 60 million square kilometers(23 million square miles) of tropical seas absorb an amount of solar radiation equal in heatcontent to about 29 billion kiloliters (250 billion barrels) of oil.

There are two primary types of ocean energy: mechanical and thermal. The rotation of the earth and the moon's gravitational pull create mechanical forces.<sup>[1]</sup> The rotation of the earth creates wind on the ocean surface that forms waves, while the gravitational pull of the moon creates coastal tides and currents. Thermal energy is derived from the sun, which heats the surface of the ocean (at 26<sup>0</sup>C or 79<sup>0</sup>F) while the depths

(at 4°C or 39°F) remain colder. This temperature difference allows energy to be captured and

converted to electric power.

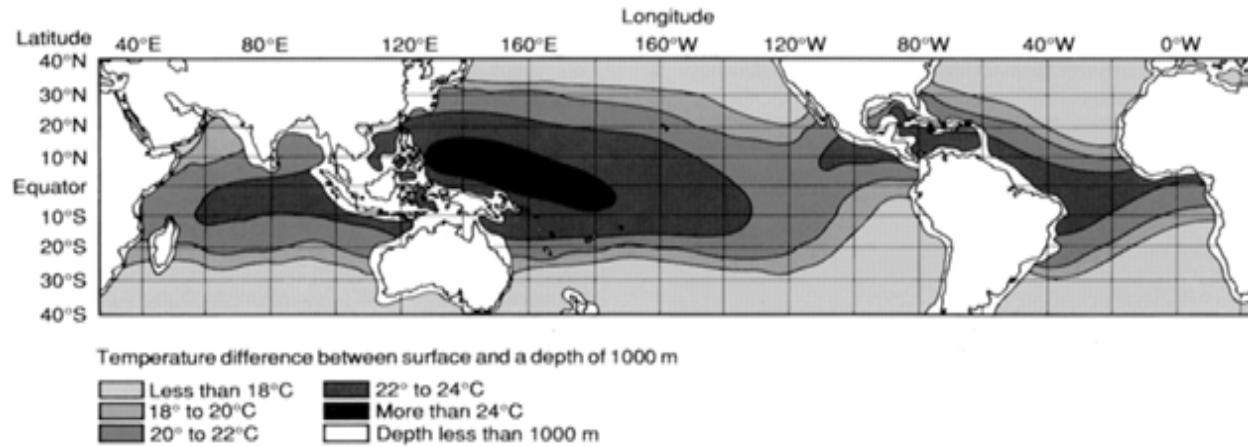

Figure 1 Ocean Temperature Differences between Surface and 1,000 Meters Deep.

## 2. History

An attempt to develop an OTEC technology is started in the 1880's. In 1881 French physicist Jacques Arsoned'Arsonval proposed the idea. Hisdisciple, French engineer and businessman Dr. Georges Claude, adopted the idea and in 1930 built an OTEC open cycle plant atMatanzas Bay (Cuba), where a 22-kW generator system was used to light an array of lamps. In 1935 Claude built another power generating ship of 1200 KW at the coast of the Brazil. Further in 1956, French scientist designed a 3 MW plant for Abidjan. In 1962 Anderson's focused on increasing component efficiency and they patent their design in year 1967 for a closed cycle. At starting of 1970 Japan started start their researches over OTEC technology, on 14 October 1981 Tokyo electric power co. succeed with 120 KW of power on Nauru. In 1974 the U.S. established the Natural Energy Laboratory OF HawaiiAuthority was established at Keahole Point on the Kona coast of Hawaii. India piloted a 1 MW floating OTEC plant near Tamil Nadu. Its government

continues to sponsor various researches in developing floating OTEC facilities. In 2006 Makai Ocean engineering was awarded by U.S. Office of Naval Research to produced significant quantity of Hydrogen in at Sea. In 2011 Makai Ocean engineering completed the design and construction of OTEC heat exchanger, that are used to generate 1000 MW of power for which at 2013 Makai Ocean engineering was awarded.

## 3. The Basic Process

OTEC systems rely on the basic relationship between pressure (P), temperature (T) andvolume (V) of a fluid, which can be expressed by the following equation:

$$\frac{PV}{T} = a \text{ constant}$$

Where pressure, temperature and the volume of a fluid can beclosely controlled by manipulating the other two variables.

Hence the differential in temperature of the fluid can be used to create an increase

inpressure in another. The increase in pressure is utilized to generate mechanical work.

There are basically three types of OTEC systems developed that can utilize sea watertemperature differentials – they are: a closed-cycle, an open-cycle and a hybrid-cycle.

### 3.1 Closed cycle OTEC System

The closed-cycle system uses a working fluid, such as ammonia, pumped around a closed loop, which has three components: a pump, turbine and heat exchanger (evaporator and condenser).<sup>[4]</sup> Warm seawater passing through the evaporator converting the ammonia liquid (4) into high-pressure ammonia vapour at (1). The high-pressure vapour at (1) is then fed into an expander where it passes through and rotates a turbine connected to a generator. Low-pressure ammonia vapour leaving the turbine (2) is passed through a condenser, where the cold seawater cools the ammonia, returning the ammonia back into a liquid (3).

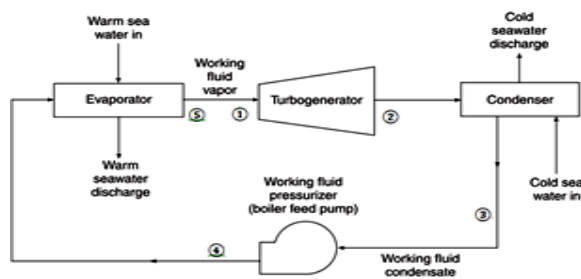

Figure 2 Schematic diagram of a closed-cycle OTEC system.

### 3.2 Open cycle OTEC System

The steps of the open, cycle are: (1) Flash evaporation of warm sea water in a

partial vacuum; (2) expansion of the steam through a turbine to generate power; (3) condensation of the vapour by direct contact heat transfer to cold sea water; and (4) compression and discharge of the condensate any residual non condensable gases. Unless fresh water is a desired by-product, open cycle OTEC eliminates the need for surface heat exchangers. The name ‘open cycle’ comes from the fact that the working fluid (steam) is discharged after a single pass and has different initial and final states; hence, the flow path and process are ‘open.’

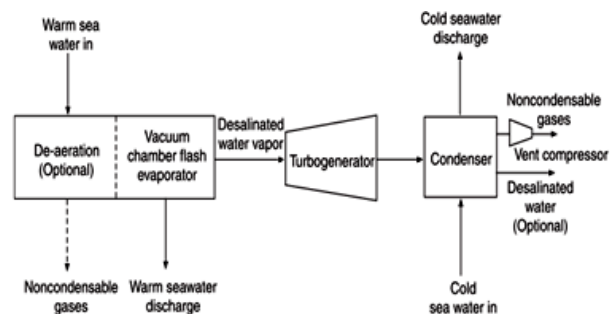

Figure 3 Schematic diagram of an open-cycle OTEC system.

[1]

The essential features of an open cycle OTEC system are presented in Figure 3. The entire system, from evaporator to condenser, operates at partial vacuum, typically at pressures of 1-3% of atmospheric. Initial evacuation of the system and removal of non-condensable gases during operation are performed by the vacuum compressor, which, along with the sea water and discharge pumps, accounts for the bulk of the open cycle OTEC parasitic power consumption.

The principal disadvantage of open-cycle OTEC is the low system operating pressures, which necessitate large components



to accommodate the high volumetric flow rates of steam.

### 3.3 Hybrid Cycle OTEC

Hybrid cycles combine the desalinated water production capabilities of open cycle OTEC with the potential for large electricity generation capacities offered by the closed cycle.

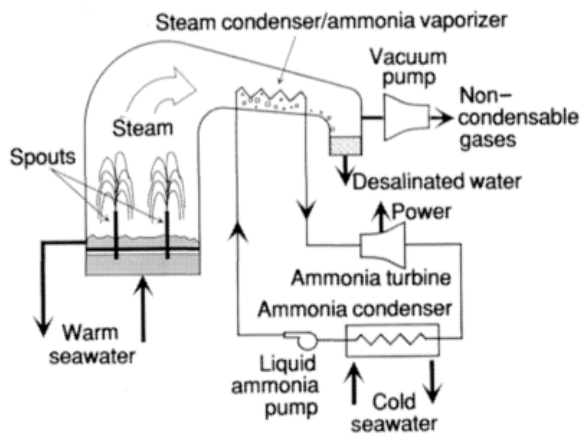

Figure 4 A Hybrid OTEC system

In this concept, warm sea water enters the vacuum chamber where it flash evaporated into steam, which is similar to the open cycle evaporation process. The steam vaporizes the working fluid (ammonia) of a closed cycle loop on the other side of the ammonia vaporizer. The vaporized fluid then drives the turbine which enable shaft to rotate, which is coupled with generator that produce electricity.<sup>[3]</sup> The steam condenses within the heat exchanger to produce desalinated water. As shown in figure 4.

### 4. System Model to Calculate Efficiency

The major system components are illustrated in Fig. 5. Numbers in the working fluid path are keyed to thermodynamic processes shown on the standard Rankine cycle diagram in Fig. 6. The plant operates between warm surface water having temperature  $T_H$  and cold water drawn from the ocean depths having temperature  $T_C$ . Typically the temperature difference

$$\Delta t = T_H - T_C \text{ -----(1) lies}$$

in the range between 18 and 22K.

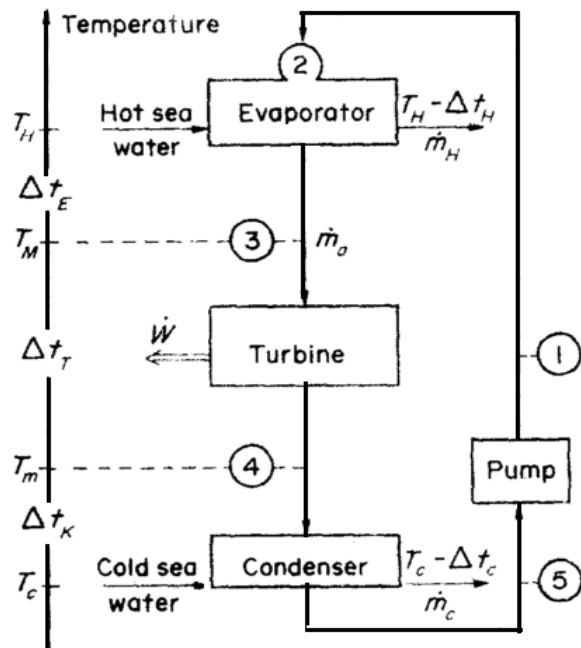

Figure 5 Nomenclature and definitions of temperature differences for the simple Rankine cycle OTEC model,

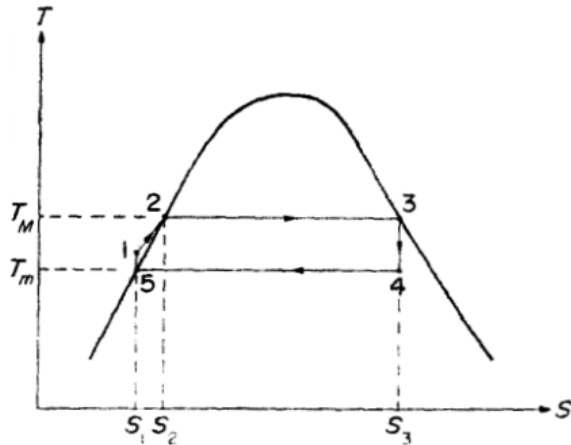

Figure 6 Temperature-entropy diagrams for the working fluid vapour dome and the standard.

### 4.1 Rankine cycle

Liquid ammonia is pumped to the evaporator (process 5-1) where, at constant pressure, the liquid is brought to the boundary of the liquid-vapour region by the preheater (process 1-2). The working fluid is vaporized at constant pressure and temperature (process 2-3). This temperature is denoted by  $T_M$ , the maximum temperature of the Rankine cycle. The vapour then expands isentropically through the turbine (process 3-4), after which it is returned to the liquid state at constant pressure and temperature in the condenser (process 4-5). This latter temperature, the minimum experienced by the working fluid, is denoted by  $T_m$ .

The temperature differences

$$\Delta t_E = T_H - T_M \quad \text{-----} \quad (2)a$$

$$\Delta t_T = T_M - T_m \quad \text{-----} \quad (2)b$$

$$\Delta t_K = T_m - T_C \quad \text{-----} \quad (2)c$$

are of considerable importance in the analysis of the OTEC system performance. To promote efficient heat transfer with minimum surface area of the heat exchangers,  $\Delta t_E$  and  $\Delta t_K$  should clearly be as large as possible. On the other hand, the idealized cycle work is directly proportional to  $\Delta t_T$ . Since the sum of the three differences equals the total plant  $\Delta t$ , the allotment of the differences is a crucial design option. A choice commonly made for preliminary design purposes is

$$\Delta t_E \approx \Delta t_K \approx (1/4) \Delta t ; \Delta t_T \approx (1/2) \Delta t$$

----- (3)

As will be shown later, the precise allocation of these temperature differences is a function of many power plant parameters. The heat addition and rejection for the Rankine cycle is usually analyzed in terms of the specific enthalpy. But it is advantageous here to take a more primitive view and work directly from the T-S diagram.

On the liquid and vapour sides, respectively. Consequently the heat added to the cycle is

$$Q_{in} = T_M (S_3 - S_1) - (1/2)(T_M - T_m) (S_2 - S_1)$$

----- (4)

Where the entropy differences and temperatures are defined in Fig. 6. Similarly, the heat rejected is

$$Q_{out} = T_m (S_3 - S_1) \quad \text{-----} \quad (5)$$

So for this vapour power cycle the network will be for idle process

$$W_{net} = Q_{in} - Q_{out} \quad \text{-----} \quad (6)$$

The thermal efficiency will be

$$\eta_{th} = (W_{net}) / Q_{in}$$

$$\eta_{th} = (Q_{in} - Q_{out}) / Q_{in}$$



$$\eta_{th} = \frac{[T_M(S_3 - S_1) - (1/2)(T_M - T_m)(S_2 - S_1)] - [T_m(S_3 - S_1)]}{T_M(S_3 - S_1) - (1/2)(T_M - T_m)(S_2 - S_1)}$$

$$\eta_{th} = 1 - \frac{[T_m(S_3 - S_1)]}{T_M(S_3 - S_1) - (1/2)(T_M - T_m)(S_2 - S_1)} \quad (7)$$

#### 4.1.1 Factor affecting efficiency of OTEC Plant

Efficiency of an OTEC plant depends upon temperature difference between hot and cold fluid as well the material and design construction of heat exchanger, cold water carrying pipes. Heat exchanger design efficiency depends upon the overall heat transfer coefficient, fouling factor etc. the bio fouling over the equipment's cause reduction in heat transfer capacity of heat exchangers. Bio fouling in OTEC heat-exchangers was identified as a potential obstacle for commercial implementation of the OTEC plant. Pipe technology to supply the deep cold water necessary for the OTEC process. There

#### Comparison of Unit Cost of OTEC with Conventional Energy Sources in the Pacific Region (1990).

	Plant capacity (MW)	Plant life (year)	Capacity factor (%)	Annual output (GWH)	Cost of power (U.S. \$/KWH)
Wave	1.5	40	68	9	0.062-0.072
Hydro	1.2	40	48	5	0.113
Diesel	0.9	20	64	5	0.126
OTEC	1.256	30	80	8.8	0.149

is enough theoretical and experimental data to predict the design, construction and deployment, apart from this water chemistry and chemical reaction between materials, and pressure and temperature at deep sea level, site selection for erection of plant, tropical temperature difference between sea level's also play a vital role in efficiency of OTEC plant.

## 5. Economics of OTEC

OTEC power will be cost effective if the unit cost of power is comparable with other power plants such as wave, hydro and diesel. However, it is important that all capital costs and ongoing maintenance/service costs are included so that the individual technologies are compared on a level playing field. Work carried out by Dr Luis Vega and his team in Hawaii has shown that for plants of the 1 MW range, the unit cost is considered comparable, see table below.



## *Estimation of unit cost of electricity from OTEC power in India (1999)*

Power output	Power output	Heat exchanger cost	Cost of cold water pipe	Cost of barge	Mooring cost	Turbine plus inst. Cost	Total cost	Cost of power
MW	net MW	US\$ m	US\$ m	US\$ m	US\$ m	US\$ m	US\$ m	(US\$/KWH)
1	0.617	1.7	0.69	0.69	2.09	1.16	6.42	0.189
25	15.39	44.4	1.74	2.33	3.49	17.44	69.42	0.082
50	30.88	878	2.67	4.55	4.65	34.49	134.67	0.079
100	64.23	1525	4.55	9.3	5.81	68.76	242.1	0.068

To enhance the economics of OTEC power stations, various initiatives have been proposed based on marketable OTEC by- or co-products. OTEC proponents believe that the first commercial OTEC plants will be shore-based systems designed for use in developing Pacific island nations, where potable water is in short supply. Many of these sites would be receptive to opportunities for economic growth provided by OTEC-related industries.

## 6. Conclusions

The technologies for OTEC, wave, non-barrage tidal, and offshore wind energy are still fairly new. Further researches are needed on the efficiency enhancement and optimize the net power output as well as economic feasibility of renewable ocean energy projects. However, research has shown that these technologies hold promise, and further research and development could help address one of the most serious threats to the global climate change, by reducing dependence of fossil fuels. The main advantages of OTEC are that the method is

fuel free. The disadvantages include high capital cost, potential for hostile ocean environment during construction and use and an overall lack of familiarity with OTEC technology.

The feasibility of the OTEC concept itself is not so much with performance as with capital investment. Therefore, it may be desirable to relax some of the performance-based optimal conditions, in favor of reducing the cost of certain components, for example the heat exchangers and the cold water pipe. To compromise with its efficiency. Research is going on the field of minimizing the factor affecting the efficiency of OTEC, and adopt a suitable methodology with proper selection of material of an equipment's, that withstand on that oceanic environment with greater equipment efficiency as well as overall efficiency in economical view.

## References

- [1] Ocean Energy Overview, U.S. Department of Energy, July 2009, DOE/GO-102009-2823



[2] Thomas H. D; Ocean Thermal Energy Conversion: Natural Energy Laboratory of Hawaii Authority, Third Edition, ICG Publishing Ltd, London, 2000.

[3] panchal. C. and K.J.Bell “simultaneous production of desalinated water and power using a hybrid cycle plant.”Journal of solar energy engineering, vol 109 1987.Pp 156-160.

[4] Robin Pelc, Rod M. Fujita, Renewable energy from the ocean, Marine Policy 26 (2002) 471–479.

[5] Takahashi, Patrick, Trenka, Andrew, “Ocean Thermal Energy Conversion”, John Wiley & Sons, chichester, 1996.

[6] Cohen, R. 1982. Energy from the Ocean.Phil. Transactions, Royal Society. London. A 307: 405-437.

[7] Daniel, T. 1999. A Brief History of OTEC Research at NELHA.Natural Energy Laboratory of Hawaii.

[8] S. M. Masutani and P. K. Takahashi,University of Hawaii at Manoa, Honolulu, HI, USA

[9] H. Searl Dunn , Optimization Of An Ocean Thermal Energy Conversion System, Department of Engineering, Swarthmore College, Swarthmore, Pennsylvania, U.S.A. Ocean Engg. Vol. 4, pp. 23-39.

[10] Ocean Thermal Energy Conversion (OTEC): Technical Viability, Cost Projections and Development Strategies T.J. Plocek and M. Laboy, Offshore Infrastructure Associates; J.A. Marti, Technical Consulting Group