

## Mechanical tools of Natural Resource harvesting potential in Indian Industries

Rupesh Kalantri,<sup>1</sup> Prof. B. Kumar<sup>2</sup>

1. Research Scholar, Department of Mechanical Engineering, Sunrise University, Alwar.
2. Research Supervisor, Department of Mechanical Engineering, Sunrise University, Alwar.

### Abstract-

*Water & Coal are the blood & food of a thermal power station. Water is employed in Boiler for Steam generation, in cooling towers as a coolant. 90% of water consumption in thermal power plant as in the sort of Evaporation in Cooling towers. This study provide the direct edges to power industries for reducing their power generation cost, by decreasing water requirements, and indirect benefits like reduction in auxiliary power consumption.*

*This study shows that there is a hues potential of water conservation /saving in thermal power plant. By increasing C.O.C from 2 – 8, we can reduce water consumption & saving of water in 250MW Unit is 17520-157680 Tons per annum. In 500 MW Unit water saving is 8760 – 227760 Tons per annum. In 600 MW Unit water saving is 17520 -280320 Tons per annum. In 660 MW unit water saving is 17520- 297840 Tons per annum. By decreasing drift losses from 0.02 % to 0.01 % by using techniques of Pharpur Cooling towers & by installing Drift Eliminators we can save 0.01% of circulating waters in Cooling towers. By adopting hybrid cooling tower we can save >25% water in Thermal power plant Cooling towers. Modifying chemical treatment program can easily achieve COC up to 8. This CW Blow down water can be used in Bottom Ash disposal system & Coal Dust Suppression system instead of fresh water. This practice is also reduce fresh water consumption in Thermal power plant. By adopting these techniques all power plants to compile govt. norms of specific water consumption.*

**Key Words-** Thermal Power Plant, Water conservation, Cooling Tower, Cycle of Concentration, Power Generation Cost Reduction etc.

### I. INTRODUCTION-

Water is that the essential needs for thermal power plants. Water is employed in Boiler for Steam generation, in cooling towers as a coolant. As we tend to all grasp whole world is suffering, the shortage of contemporary water for drinking & utilization of human being. Immense amount of water is needed for power generation within thermal power station. This water consumption in Indian coal primarily based thermal power plant is around 1100 million m<sup>3</sup>, which is far over our neighbor country China. That has power generation capability is around 2.5 times then India. In

Indian power industries have huge potential to cut back water consumption by adopting new techniques or by modifying the current techniques with minor changes. 90% of water consumption in thermal power plant as in the sort of Evaporation in Cooling towers. It are often reduce by adopting some techniques such as.

- 1) By increasing C.O.C of circulating cooling water
- 2) By decreasing blow down with modification
- 3) By decreasing drift losses
- 4) Modified chemical treatment programs
- 5) By adopting Air Cooled Condenser techniques rather than Wet Cooling Towers.
- 6) By adopting hybrid C.T.
- 7) By employment & utilize of Blow down water

**Power Sector at a Glance in India:** India is a very big and fast developing country in the world. Whose position as per area is 4<sup>th</sup> largest country in the world & as per population, 1.35 Billion peoples, ie 2<sup>nd</sup> biggest in the world after China. The population growth of India is around >1%, while China population growth is around 0.5%, with increasing this rate we beat China till 2024 years and became world biggest country as per population.

India is a fast developing country, to meet and fulfillment the basic requirement & self-dependent country, huge industrialization is needed. For fulfillment this requirements, huge amount of Electricity is needed to fulfill the requirements of India. There are various methods to produce electricity, such as solar power, Wind Power these are also known as renewable energy or Green energy. "Hydro power Plant, Nuclear Power Plant & Thermal Power Plant are another option to produce electricity. India has a total power generation installation capacity as on (31.07.2020 source Central Electricity Authority (CEA)) 3,71,977 MW[1], out of which Coal based power generation -199594.50 MW+ Lignite coal based power generation-6360 MW, Gas based power generation -2491.51 MW, Diesel based power generation-509.71 MW, Nuclear based power generation -6780 MW, Hydro power generation capacity-45699.22 MW and (Renewable Energy Sources) Wind +Solar power generation capacity-88041.91 MW". In Thermal power plants state government share -65631.50 MW, Centre government share (NTPC)-59760 MW and Private companies produce 74173 MW. In India Thermal Power Plant produce >55% of total power generation. To fulfill the requirements of India without thermal power plant doesn't possible. Below pie chart shows a graphical representation of power generation with this techniques.

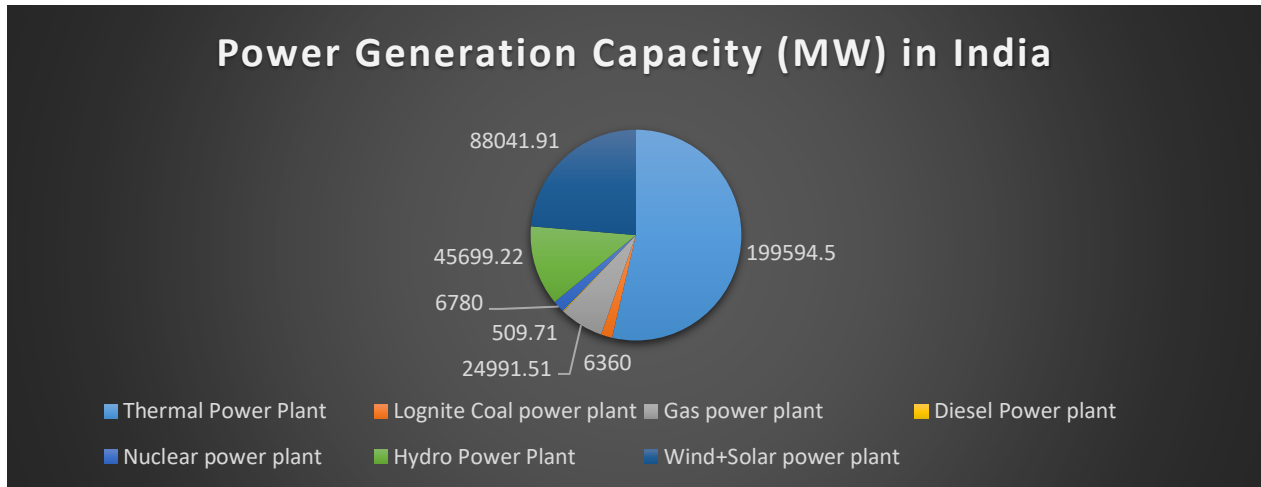

Fig-1 Power Generation Installed Capacity in India

According to Central Electricity Authority, till August 2019, there were 269 thermal power plants in India. These plants consumes 87.8% of the total amount of water consumed by whole power industrial sectors[2].

## II. Govt. Norms for water consumption in Thermal Power Plant

Before 2015, there were no limit for the water consumption per MWH in thermal power in India. Till that time the average water consumption of coal based power plants 5-7 cubic meter per MWH, according to NITI AAYOG[3]. In term of installation capacity& water uses, thermal power plants are the biggest consumer of fresh water in power industries.

“On 07<sup>th</sup> December 2015, Ministry of Environment Forest and Climate change (MoEFCC) issued a notification, and bound a limit for water consumption for old thermal power plant, 3.5 cubic meter/MWH, & those thermal power plant installed after 01 January 2017, water consumption limit is 3 cubic meter/MWH[3]”.

Water is the primary requirements for a thermal power plant. Water is used for the following process in thermal power plant, such as Condenser cooling water (C.T makeup), Boiler water makeup, Portable Fire & service water, Ash disposal, Coal and Dust suppression, Gardening purpose etc.

## III. Optimization of water in Thermal Power Plant

Fluid is used as a coolant in Thermal Power Plant. Although we identify the major areas of water consumption in thermal power plant. Such as

1. Heat transfer system for condenser & plant Auxiliaries.
2. Steam cycle m/up water.

3. Various Heat Exchanger cooling system.
4. Demineralize water production & Regeneration.
5. Condensate Polishing Unit Regeneration.
6. Fire & Service water.
7. Ash disposal system requirement.
8. Coal dust suppression system.
9. Evaporation loss from Raw water reservoirs.
10. Gardening purpose etc.

#### **IV. Cooling water system**

Cooling Tower is known in every power industry. A water tower that is used to extract the heat produced by different heat generation operations and the hot water returns to the cooling tower. The water is cooled in and recycled via the cooling tower in the marsh. That is the cooling tower's basic concept. Cooling water is required for condensing steam in surface condenser. And also required for auxiliary cooling such as heat Exchanger, Air Condensing & Ventilating system cooling. In surface condenser, the inlet & outlet cooling water temperature rise around 10 degree Celsius.

#### **V. Types of Cooling Tower**

1. Natural Draft Cooling Tower.
2. Induced Draft Cooling Tower.
3. Forced Draft Cooling Tower.
4. Hybrid Cooling Tower.

##### **➤ Natural Draft Cooling Towers:**

In large-capacity thermal power plants, where the overall heat rate is approximately more than 210 MW, natural draft cooling towers are widely used. Their draft, provided by height and stack size, reduces the cost of operating costs and the cost of power consumption in thermal power plant. The other benefits of this type of cooling tower are that it has a long service life, low noise pollution, and low maintenance costs. They have minimum drift losses in terms of water savings as opposed to all other types of cooling systems used in thermal power plants.

Main components of Natural Draft Cooling Towers:

- Supporting hyperbolic body shape (reinforced concrete, steel).
- Sheathing, Cooling Fill, Eliminators of Drift.
- Water delivery system, including nozzle spray and water basin,

The cooling towers of the natural draft are used in the same way as the Induced Draft or forced draft cooling towers used in the Thermal Power Plant to eliminate low-potential heat produced in the generation process of steam. The cooling concept (atmospheric cooling with wet technology)

is still the same; fans are absent in Natural Draft cooling towers. Using a natural draft with the assistance of ambient air, heat is extracted from the cooling tower. Natural draft cooling towers are often constructed according to the particular requirements of the customer and specific installation conditions site. Mostly they have used in dry & clean areas, where no dusty climate and low Humidity.

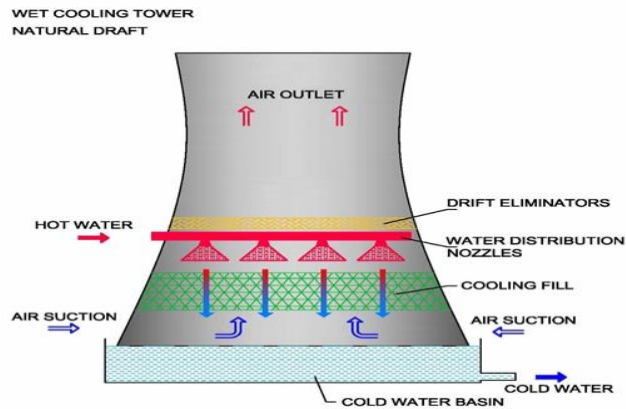

Fig-2 -Natural Draft Cooling Tower [4]



Fig-3 -Natural Draft Cooling Tower [4]

### ➤ Induced Draft Cooling Tower:

A fan at the discharge end comes with the induced draft cooling tower or mechanical draft tower, which pushes air through the tower upwards. The ventilator removes the discharge from hot moist air. This creates high velocities of exiting and entering air, decreasing the probability of recirculating air discharged, air circulates back to intake system. In general, the induced draft cooling tower provides the most efficient and cost-effective solution for most cooling needs. For all power and industry applications and all environmental conditions, IDCT style cooling towers are used worldwide.

The following benefits are offered by the Induced Draft Cooling Towers:

- Flexibility
- Cost efficiency
- Nearly constant air flow, regardless temperature of ambient air.
- Adapted to any flow of water
- Flexible operation by closing certain cells

- Adapted to elevated thermal output
- All structure types: such as wood, FRP, concrete, steel, S.S etc.
- All kinds of heat exchange surfaces, for high performance.

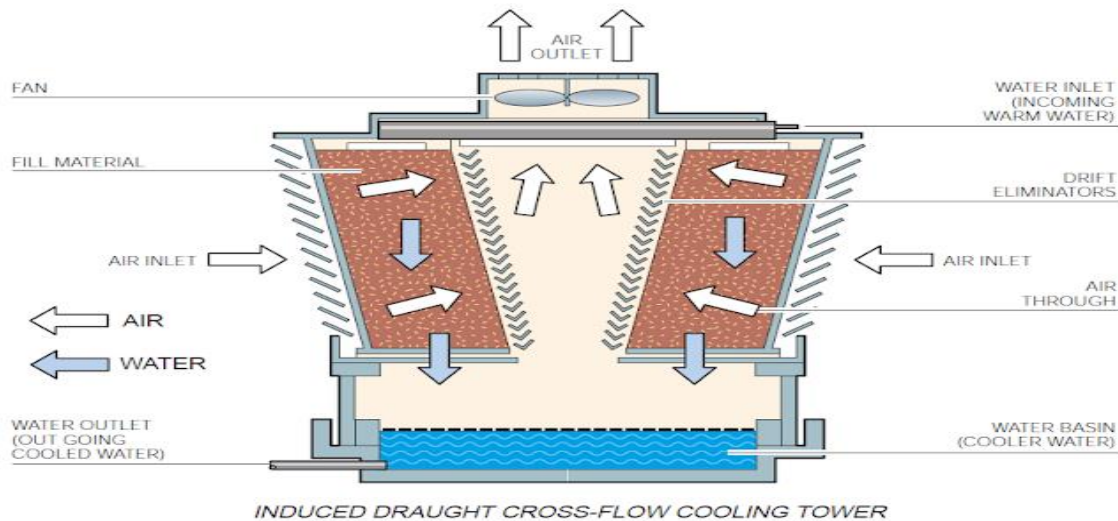

Fig-4 Induced Draft Cooling Tower [5]

➤ **Forced Draft Cooling Tower:**

Mechanical or Forced Draught Cooling Tower: A fan is used to circulate the air in this type of cooling tower. It needs a very high rate of cooling water when the thermal power plant operates at full load. The engine is used to spin the fans at speeds of about 1000 rpm. The operating principle is the same as the cooling tower for the natural draught, but the only difference is that the fan is mounted on the cooling towers here, or on the side of the cooling towers, while there is no fan for natural draft types for the cooling towers. The induced draught cooling tower is named when the fan is mounted on top of the tower, which is most popular for installation of very large sizes and requires large fan power. The forced draught cooling tower therefore comprises a horizontal fan shaft and is situated at the bottom or side of the tower and a vertical shaft is used in the induced draught cooling tower and is placed at the top of the cooling tower (as shown in below figures).

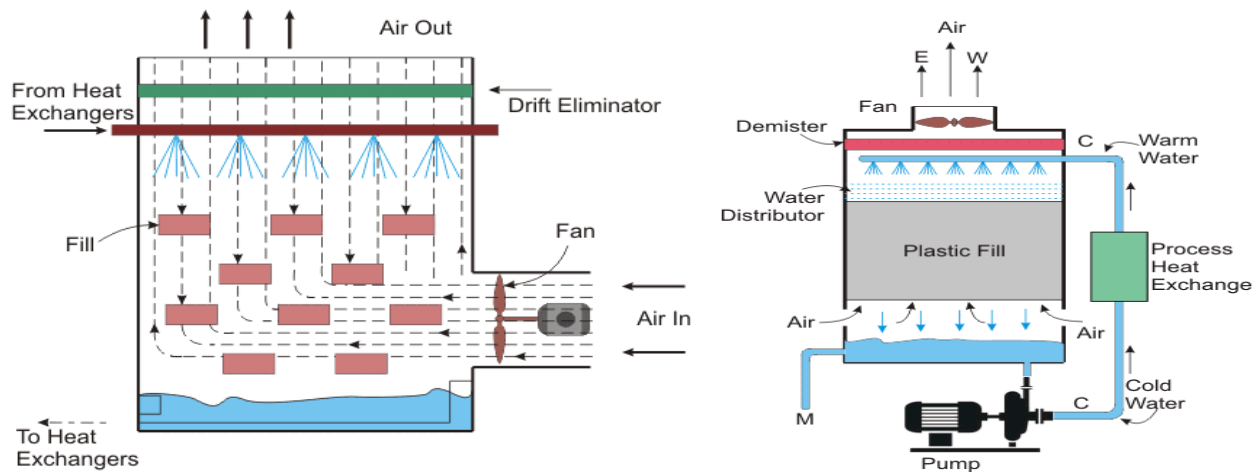

Fig-5 Forced Draft cooling tower [6] Fig-6 Forced Draft cooling tower [6]



Fig-7 Forced Draft cooling tower [7]

➤ **Hybrid Cooling Towers:**

Hybrid cooling towers are an acceptable combination of a wet and dry cooling system with a more desirable environmental effect, fulfilling challenging environmental criteria and, in the current scenario, being the most suitable for water saving in thermal power plants. They allow steam drift to be reduced (the "steam plume", particularly noticeable during cold wet weather and in winter). The elimination of the steam plume is particularly helpful in urban areas, industrial areas, and close to roads with freezing

potential. The hybrid cooling towers minimize water consumption and, as needed in thermal power plants, provide the total heat rate.

Major parts of Hybrid Cooling Towers:

- Outer shell (materials like : FRP, steel, S.S, Concrete etc.)
- Supporting steel or FRP structure
- Water Basin, Fan Stack, Drift Eliminator, Cooling Fills, etc.
- Air-dry exchangers for cooling
- Water delivery system, including nozzle spraying & distribution,

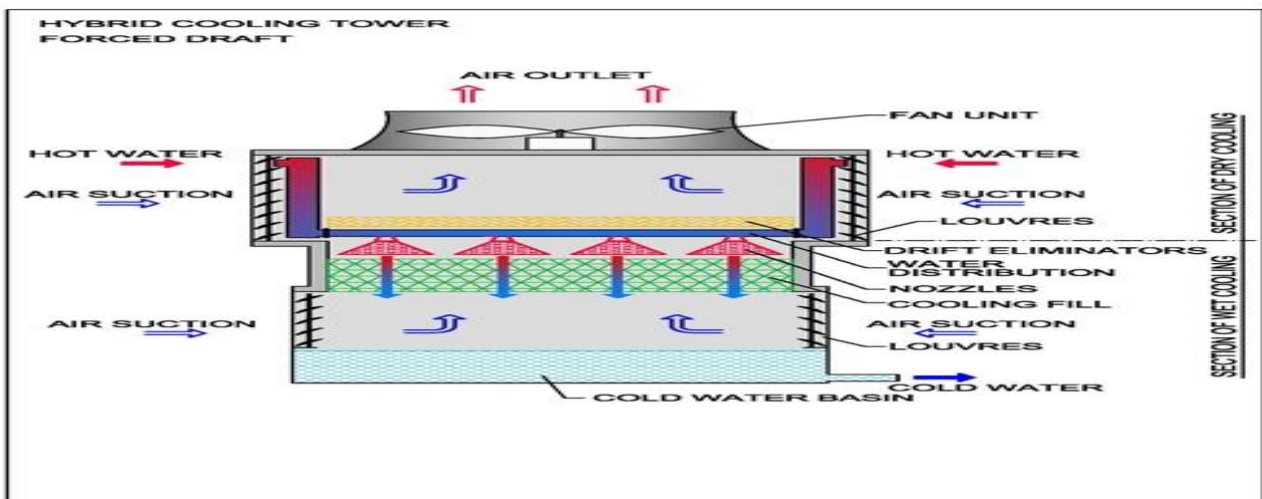

Fig-8 Hybrid (Wet+ Dry) Type Cooling Towers [8]

## VI. Present Scheme of Thermal Power in India

The Existing scheme of a Thermal Power Plant with Cooling Towers. Here shown in the Figures a Natural draft Cooling towers, It may be induced draft or forced draft types, that is depend upon the designing parameters & which type of cooling towers is adopted by technical team at the time of installation. The drift losses for IDCT types and FDCT types cooling tower has 0.02% of circulating rate[10](Perry and Green 2008) . While in Natural draft Cooling towers & Hybrid types of cooling towers have the Drift losses 0.01% of the circulating rate. The designing of cooling tower plays an important role in the water saving. Ie 0.01% of circulating water[9](Paharpur 2018).

In Below figures shows CW Blow Down taping given from cold water side.



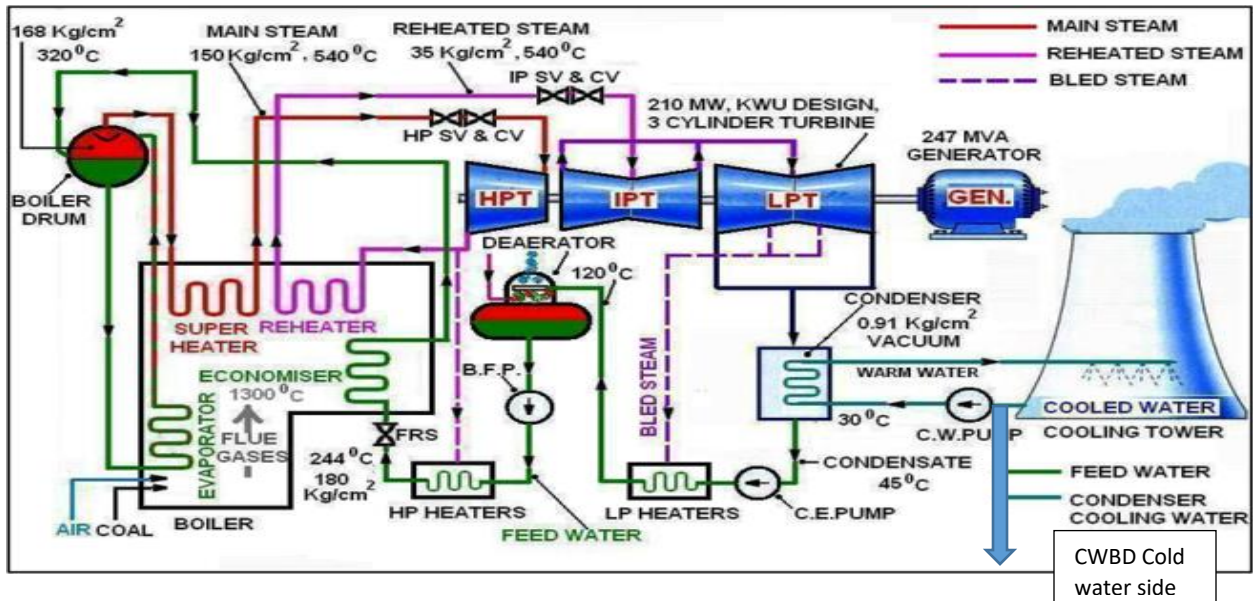

Fig-9 An Existing schematic diagram of Thermal Power plant with WCT.

## VII. Proposed /Modification required for water saving in Thermal Power Plant

1. If IDCT or FDCT types of cooling towers are installed than the Drift losses is more as compare to Natural draft or Hybrid type cooling towers. For reducing drift losses 0.01% of circulating water, we have to introduce Pharpur cooling towers drift loss Eliminator. Such types of modification is very easy & economical. Against the water saving in cooling towers.
2. In India mostly thermal power plant have CW Blow down given from cold water side. That is also a disadvantage. If we modify this Blow Down taping from direct condenser return line/Hot water side than we can save more water as shown in the table-4. The major concern of CWBD from Hot water side is the government norms that we cannot discharge water >5 degree Celsius of make water. But this blow down water have >10 degree Celsius than makeup water. For this query first we passed this hot water from sequential 2-3 cascades and then store in reservoir, after cooling we can discharge this blow down water.

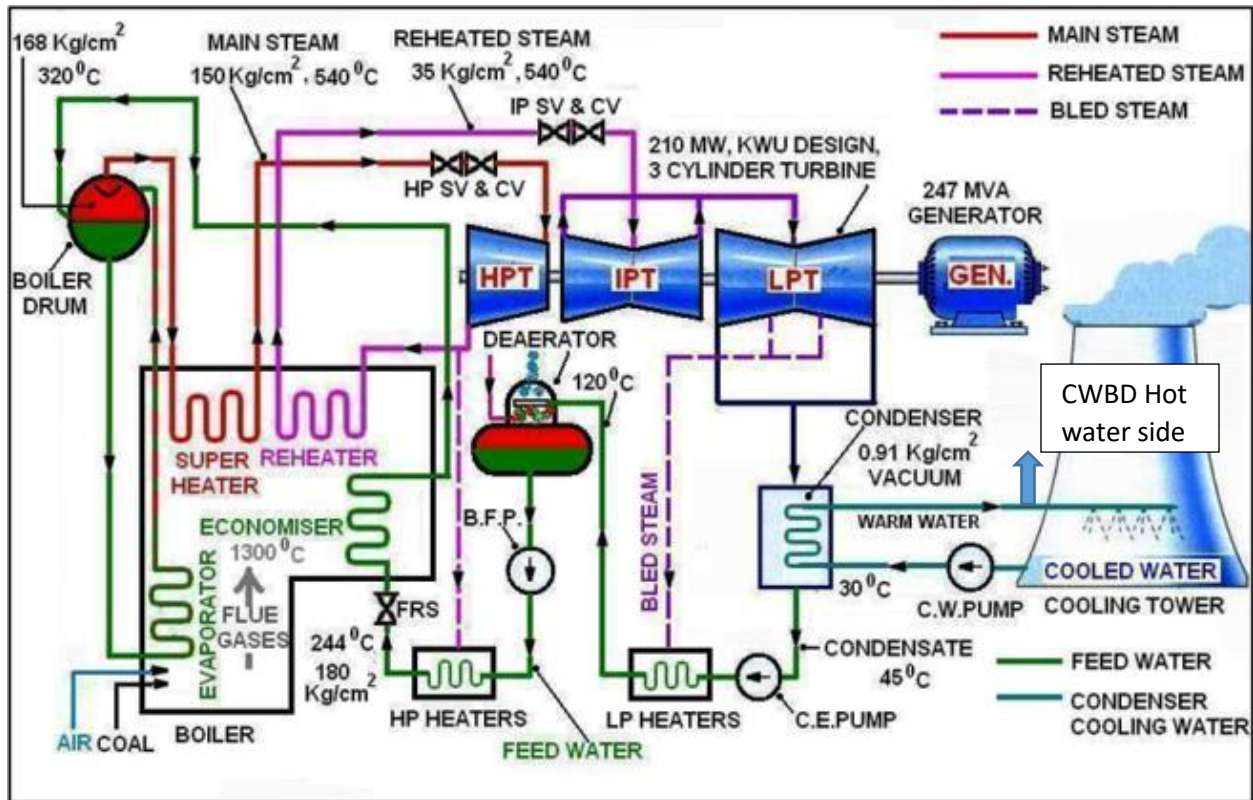

Fig-10A Modified scheme diagram of Thermal Power plant with WCT showing Hot CWBD

### VIII. Cycle Of Concentration (C.O.C)

COC is the short form of Cycle Of Concentration. Means Circulating water parameters like Conductivity, TDS, Hardness, Chloride and Silica is divided by Makeup water parameters like Conductivity, TDS, Hardness, Chloride and Silica etc.

The most used & Reliable parameters for calculation of COC in sweet water system is Total Hardness. While in Sea water system Conductivity/TDS is used for calculation of COC.

**Mathematical representation of COC = Parameters of Circulating water**

**Parameters m/up water.**

Cycle of concentration is the main monitoring parameter of circulating water. Water is consumed during circulation & heat transferring or cooling process by evaporation. During evaporation the

soft water is evaporated and salts are remains in the sump of Cooling Towers. When COC increased means concentration of dissolved salt increased in circulating water. While when COC decreased means concentration of dissolved salts decreased in circulating water. Low COC does not create any problem in cooling system. But high COC creates many problem in cooling water system, such as Scaling, Corrosion, Bio fouling etc. We finds following results of water saving by using these formulas.

**Evaporation Rate=0.00085\*1.8\*Water Recirculation rate\*Delta T (C) = in M3/hr**

**Blow down Rate = Evaporation-(COC-1)\*Drift loss / (COC-1).**

**Drift Loss= 0.01 to 0.02 of Recirculation Rate**

**Total Make up water= Evaporation+Blowdown+Drift loss.**

“The equations used for calculated for make-up water consumption are taken from Perry’s Chemical Engineer’s Handbook and is given by, (Perry and Green 2008)[10]”.

**We have carried out our study in four different Unit size Thermal power plant respectively of size 250 MW, 500 MW, 600 MW, 660 MW.**

#### **I. Case-1(Comparing 250 MW Thermal power plant).**

In India there are Many Thermal Power Plant of various Capacities of Power Generation, Small power plants also known as Captive Power Plants of size-10,15,20,25,30,45,60,80 MW. Medium capacity size power plants of 100,110,125 MW . While large size power plants of 210,250,300,500,600,660 MW Thermal Power plants are present in India. In First study we have compared water consumption in 02 different 250 MW Thermal power plant. First 01 has IDCT Type cooling tower & CW Blow down on cooling water side, 02 has Natural Cooling Tower & CW Blow down on Hot water side. The below table shows the water saving with some medication from reducing Drift losses & CW Blow Down Modification from cold water side to Hot Water side.

Table 1. Cooling water saving for 250 MW Unit

| Sr.No | COC | Present system     |                  |                   |                      | Proposed system    |                  |                   |                      | Saving              |                             |
|-------|-----|--------------------|------------------|-------------------|----------------------|--------------------|------------------|-------------------|----------------------|---------------------|-----------------------------|
|       |     | Evaporation (T/hr) | Blow down (T/hr) | Drift loss (T/hr) | Make up water (T/hr) | Evaporation (T/hr) | Blow down (T/hr) | Drift loss (T/hr) | Make up water (T/hr) | Water saving (T/hr) | *Annual Water saving (Tons) |
| 1     | 2   | 582                | 506              | 76                | 1164                 | 573                | 536              | 37                | 1146                 | 18                  | 157680                      |
| 2     | 3   | 582                | 215              | 76                | 873                  | 578                | 251              | 38                | 867                  | 6                   | 52560                       |
| 3     | 4   | 582                | 118              | 76                | 776                  | 579                | 155              | 38                | 772                  | 4                   | 35040                       |
| 4     | 5   | 582                | 70               | 76                | 728                  | 580                | 107              | 38                | 725                  | 3                   | 26280                       |
| 5     | 6   | 582                | 40               | 76                | 698                  | 580                | 78               | 38                | 696                  | 2                   | 17520                       |
| 6     | 7   | 582                | 21               | 76                | 679                  | 580                | 59               | 38                | 677                  | 2                   | 17520                       |
| 7     | 8   | 582                | 7                | 76                | 665                  | 580                | 45               | 38                | 663                  | 2                   | 17520                       |

Table-1

\* Annual water saving calculated on the basis of 365 days\*24 hours availability of the Power plant.

## II. Case-2 (Comparing 500 MW Thermal power Plant)

In This study we have compared water consumption in 02 different 500 MW Thermal power plant. First 01 has IDCT Type cooling tower & CW Blow down on cooling water side, 02 has Natural Cooling Tower & CW Blow down on Hot water side. The below table shows the water saving with some medication from reducing Drift losses & CW Blow Down Modification from cold water side to Hot Water side.

Table 2. Cooling water saving for 500 MW Unit

| Sr.No | COC | Present system     |                  |                   |                      | Proposed system    |                  |                   |                      | Saving              |                             |
|-------|-----|--------------------|------------------|-------------------|----------------------|--------------------|------------------|-------------------|----------------------|---------------------|-----------------------------|
|       |     | Evaporation (T/hr) | Blow down (T/hr) | Drift loss (T/hr) | Make up water (T/hr) | Evaporation (T/hr) | Blow down (T/hr) | Drift loss (T/hr) | Make up water (T/hr) | Water saving (T/hr) | *Annual Water saving (Tons) |
| 1     | 2   | 918                | 798              | 120               | 1836                 | 905                | 846              | 59                | 1810                 | 26                  | 227760                      |
| 2     | 3   | 918                | 339              | 120               | 1377                 | 912                | 396              | 60                | 1368                 | 9                   | 78840                       |
| 3     | 4   | 918                | 186              | 120               | 1224                 | 914                | 244              | 60                | 1218                 | 6                   | 52560                       |
| 4     | 5   | 918                | 110              | 120               | 1148                 | 916                | 169              | 60                | 1145                 | 3                   | 26280                       |
| 5     | 6   | 918                | 64               | 120               | 1102                 | 916                | 123              | 60                | 1099                 | 3                   | 26280                       |
| 6     | 7   | 918                | 33               | 120               | 1071                 | 917                | 93               | 60                | 1070                 | 1                   | 8760                        |
| 7     | 8   | 918                | 11               | 120               | 1049                 | 917                | 71               | 60                | 1048                 | 1                   | 8760                        |

Table-2

\* Annual water saving calculated on the basis of 365 days\*24 hrs.Availability of the Power plant.

### III. Case-3 (Comparing 600 MW Thermal power Plant)

In This study we have compared water consumption in 02 different 600 MW Thermal power plant. First 01 has IDCT Type cooling tower & CW Blow down on cooling water side, 02 has Natural Cooling Tower & CW Blow down on Hot water side. The below table shows the water saving with some medication from reducing Drift losses & CW Blow Down Modification from cold water side to Hot Water side.

Table 3. Cooling water saving for 600 MW Unit

| Sr.No | COC | Present system     |                  |                   |                      | Proposed system    |                  |                   |                      | Saving              |                             |
|-------|-----|--------------------|------------------|-------------------|----------------------|--------------------|------------------|-------------------|----------------------|---------------------|-----------------------------|
|       |     | Evaporation (T/hr) | Blow down (T/hr) | Drift loss (T/hr) | Make up water (T/hr) | Evaporation (T/hr) | Blow down (T/hr) | Drift loss (T/hr) | Make up water (T/hr) | Water saving (T/hr) | *Annual Water saving (Tons) |
| 1     | 2   | 1102               | 958              | 144               | 2204                 | 1086               | 1015             | 71                | 2172                 | 32                  | 280320                      |
| 2     | 3   | 1102               | 407              | 144               | 1653                 | 1094               | 476              | 72                | 1642                 | 11                  | 96360                       |
| 3     | 4   | 1102               | 223              | 144               | 1469                 | 1097               | 294              | 72                | 1463                 | 6                   | 52560                       |
| 4     | 5   | 1102               | 132              | 144               | 1378                 | 1098               | 203              | 72                | 1373                 | 5                   | 43800                       |
| 5     | 6   | 1102               | 76               | 144               | 1322                 | 1099               | 148              | 72                | 1319                 | 3                   | 26280                       |
| 6     | 7   | 1102               | 40               | 144               | 1286                 | 1100               | 112              | 72                | 1284                 | 2                   | 17520                       |
| 7     | 8   | 1102               | 14               | 144               | 1260                 | 1100               | 86               | 72                | 1258                 | 2                   | 17520                       |

\* Annual water saving calculated on the basis of 365 days\*24 hrs.Availability of the Power plant.

### IV. Case-4 (Comparing 660 MW Thermal power Plant)

In This study we have compared water consumption in 02 different 660 MW Thermal power plant. First 01 has IDCT Type cooling tower & CW Blow down on cooling water side, 02 has Natural Cooling Tower & CW Blow down on Hot water side. The below table shows the water saving with some medication from reducing Drift losses & CW Blow Down Modification from cold water side to Hot Water side.

Table 4.Cooling water saving for 660 MW Unit

| Sr.No | COC | Present system     |                  |                   |                      | Proposed system    |                  |                   |                      | Saving              |                             |
|-------|-----|--------------------|------------------|-------------------|----------------------|--------------------|------------------|-------------------|----------------------|---------------------|-----------------------------|
|       |     | Evaporation (T/hr) | Blow down (T/hr) | Drift loss (T/hr) | Make up water (T/hr) | Evaporation (T/hr) | Blow down (T/hr) | Drift loss (T/hr) | Make up water (T/hr) | Water saving (T/hr) | *Annual Water saving (Tons) |
| 1     | 2   | 1224               | 1064             | 160               | 2448                 | 1207               | 1128             | 79                | 2414                 | 34                  | 297840                      |
| 2     | 3   | 1224               | 452              | 160               | 1836                 | 1216               | 529              | 79                | 1824                 | 12                  | 105120                      |
| 3     | 4   | 1224               | 248              | 160               | 1632                 | 1219               | 327              | 80                | 1626                 | 6                   | 52560                       |
| 4     | 5   | 1224               | 146              | 160               | 1530                 | 1221               | 225              | 80                | 1526                 | 4                   | 35040                       |
| 5     | 6   | 1224               | 85               | 160               | 1469                 | 1222               | 165              | 80                | 1467                 | 2                   | 17520                       |
| 6     | 7   | 1224               | 44               | 160               | 1428                 | 1222               | 124              | 80                | 1426                 | 2                   | 17520                       |
| 7     | 8   | 1224               | 15               | 160               | 1399                 | 1222               | 95               | 80                | 1397                 | 2                   | 17520                       |

Table-4

\* Annual water saving calculated on the basis of 365 days\*24 hours availability of the Power plant.

- **Graphical representation of Water Conservation vs C.O.C**

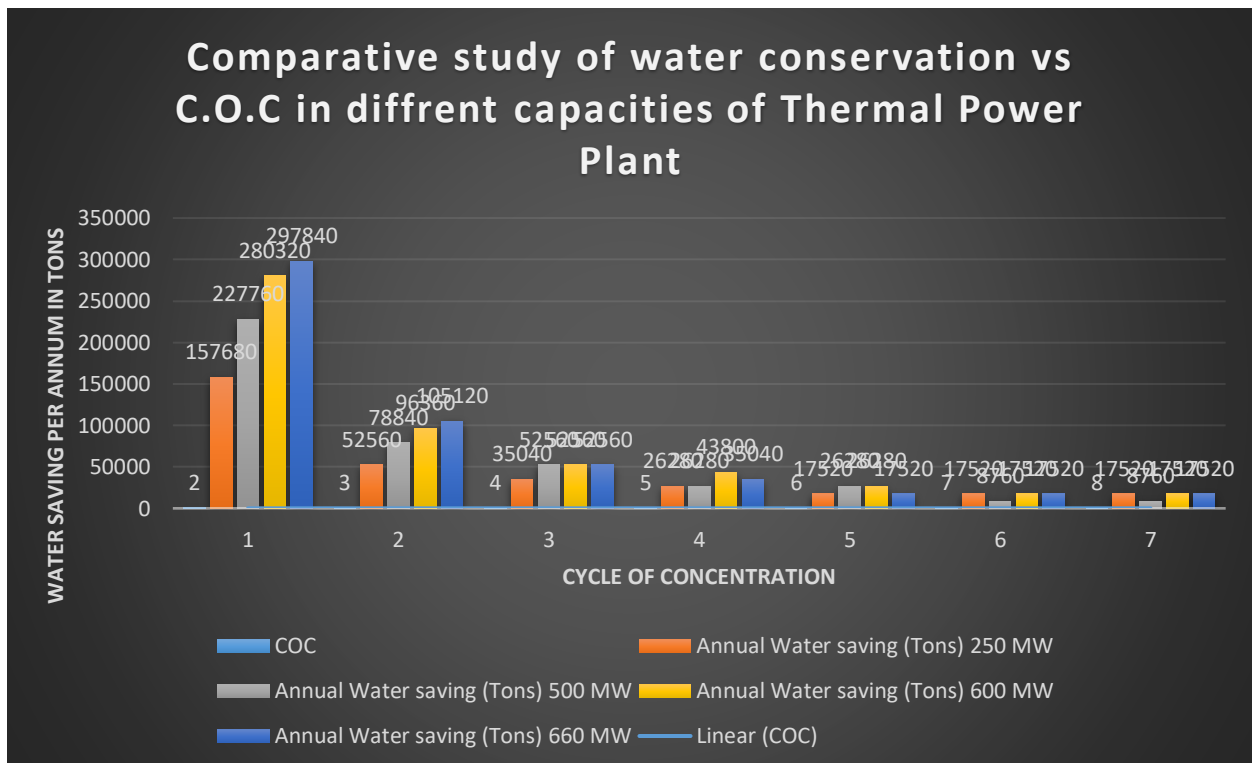

Fig-11 Comparative study of water conservation at different COC in Thermal power plant

**IX. Other Methods of water saving in Thermal Power Plant**

1. ZLD scheme- Zero Liquid Discharge scheme is most useful & much needed in present scenario of water crises. Huge amount of water is required in Bottom Ash conveying system & Coal dust suppression system. This cooling Blow down water can be used in Ash handling system & Coal Dust suppression system.
2. Demineralization Plant waste water & Condensate Polishing Unit waste water can be treated in ETP Plant. By installing RO Plant we can treat this waste water and this treated waste water is used in gardening and floor cleaning purpose.
3. The remaining waste water can be converted in to salts or solids through evaporators. And this solid waste can be disposed as per CPCB norms.
4. Air Cooled Condensers (ACCs) are recommended for new installation of any size power plant.

## **X. CONCLUSION**

The Above comparative study with some modification in existing system such as By Increasing COC & modifying CW Blow down line taping position from hot water side to direct blow down. The above study shows that there is a huge potential of water conservation /saving in thermal power plant, especially in Cooling towers, because >85 % water is used in Cooling Towers in thermal power plant. By increasing C.O.C from 2 – 8, we can reduce water consumption & saving of water in 250 MW Unit is 17520-157680 Tons per annum. In 500 MW Unit water saving is 8760 – 227760 Tons per annum. In 600 MW Unit water saving is 17520 -280320 Tons per annum. In 660 MW unit water saving is 17520- 297840 Tons per annum.

By decreasing drift losses from 0.02 % to 0.01 % by using techniques of Pharpur Cooling towers & by installing Drift Eliminators we can save 0.01% of circulating waters in Cooling towers[9].

By adopting hybrid cooling tower we can save >25 % water in Thermal power plant Cooling towers. But major concern is that to modify the current installation is very costly. Due to financial prospectus to modify present installation is not a good option. We recommend this type of techniques should be adopting for new installation of a power plant.

Modifying Chemical Treatment program: When we increase COC of cooling tower, then the major concern is Scale Formation may be occurred above when COC >5 at time we consider some change in chemical treatments. In present scenario various Anti Scalant Chemicals are in the market. By Adopting modification in chemical treatment program we can easily achieve COC upto 8.

This CW Blow down water can be used in Bottom Ash disposal system & Coal Dust Suppression system instead of fresh water. This practice is also reduce fresh water consumption in Thermal power plant.

Now it is necessity for all power plants to compile govt. norms of specific water consumption. To fulfill these norms they bound to reduce water consumption by adopting these latest modification to reduce fresh water requirements in Thermal Power Plants.

## REFERENCES

1. Central Electricity Authority, Ministry of Power, Government of India, [www.cea.nic.in](http://www.cea.nic.in)
2. Report on minimization of water requirement in coal based thermal power stations, central Electricity Authority, January 2012.
3. The Gazette of India, Ministry of Environment, Forest and climate change, notification, New Delhi, The 07<sup>th</sup> December, 2015.
4. Natural draft cooling towers pictures; <https://www.fansct.com/en/natural-draft-cooling-towers/>
5. Induced draft cooling towers pictures; <https://2.bp.blogspot.com/-kObAc8pa9Eo/VrNt-HBnkSI/AAAAAAAAAIFE/UePnEq1GINQ/s1600/induced%2Bdraught%2Bcross-flow%2Bcooling%2Btower.png>
6. Forced draft cooling tower pictures; <https://www.electrical4u.com/cooling-tower/>
7. Forced draft cooling tower pictures; <https://www.indiamart.com/proddetail/forced-draft-cooling-tower-14463951488.html>
8. Hybrid type cooling tower pictures; [https://www.fansct.com/Resizer/img.aspx?src=/root/content/industrial-cooling-technology/cooling-towers-and-equipment/hybrid-cooling-towers/hybridni-chv-s-nucenym-tahem\\_en.jpg&t=14](https://www.fansct.com/Resizer/img.aspx?src=/root/content/industrial-cooling-technology/cooling-towers-and-equipment/hybrid-cooling-towers/hybridni-chv-s-nucenym-tahem_en.jpg&t=14)
9. Paharpur (2018) Drift eliminator. <http://www.paharpur.com/products/components/drift-eliminator/>. Accessed 3 Oct 2018
10. Perry RH, Green DW (2008) Psychrometry, evaporative cooling, and solids drying. In: Perry RH, Green DW, Maloney JO (eds) Perry's chemical engineers' handbook. McGraw-Hill, New York [Google Scholar](#)
11. Recovery of additional cost incurred due to abnormal increase in water charges, before the CERC, [www.ntpc.co.in://www.cercind.gov.in/2014/technical\\_validation/NTPC121MP.pdf](http://www.ntpc.co.in://www.cercind.gov.in/2014/technical_validation/NTPC121MP.pdf)
12. Abbi YP (2011) Energy audit: thermal power, combined cycle, and cogeneration plants. The Energy and Resources Institute, New Delhi [Google Scholar](#)



13. Amit N, Prajapathi P, Singh RP, Khan SA (2015) Air cooled condensers. <https://www.slideshare.net/ravi0704/air-cooled-condensers>. Accessed 11 Oct 2018
14. Bhattacharya K (2016) Water efficiency in thermal power sector: an outline of cooling technology in India. <https://cdn.cseindia.org/userfiles/Kalyan-Bhattacharya-2.pdf>. Accessed 10 Nov 2018
15. Burton B (2018) India's coal power plants are shutting down because they don't have enough water. In: Climate change—the new economy. <http://climatechange-theneweconomy.com/indias-coal-power-plants-shutting-dont-enough-water/>. Accessed 13 Mar 2019
16. Burton B, Fernandes A (2016) Drought hits Indian coal plants and plans. <https://endcoal.org/2016/03/drought-hits-indian-coal-plants-and-plans/>. Accessed 25 Mar 2019
17. Carpenter AM (2015) Water availability and policies for the coal power sector. IEA Clean Coal Centre, London [Google Scholar](#)
18. CEA (2015) Annual performance review of thermal power stations for 2014–15. Central Electricity Authority, Ministry of Power, Government of India
19. CEA (2018) Committee on optimal energy mix in power generation on medium and long term basis. New Delhi
20. CEEW (2017) Implications of shared socio-economic pathways for India's long-term electricity generation and associated water demands. Council on Energy, Environment and Water, New Delhi [Google Scholar](#)
21. CERC (2014) Central electricity regulatory commission (terms and conditions of tariff) regulations, 2014. Central Electricity Regulatory Commission, New Delhi [Google Scholar](#)
22. CoalSwarm (2016) India and coal. In: SourceWatch. Center for Media and Democracy. [https://www.sourcewatch.org/index.php/India\\_and\\_coal](https://www.sourcewatch.org/index.php/India_and_coal). Accessed 11 Dec 2018
23. CSE (2014) The state of our power plants. Centre for Science and Environment, New Delhi [Google Scholar](#)
24. Engineering ToolBox (2003) Overall heat transfer coefficients for fluids—heat exchanger surface. [https://www.engineeringtoolbox.com/overall-heat-transfer-coefficients-d\\_284.html](https://www.engineeringtoolbox.com/overall-heat-transfer-coefficients-d_284.html). Accessed 20 Mar 2019
25. EPRI, California Energy Commission (2002) Comparison of alternate cooling technologies for California power plants economic, environmental and other tradeoffs. California Energy Commission, Palo Alto [Google Scholar](#)
26. Gao J, Zhao P, Zhang H et al (2018) Operational water withdrawal and consumption factors for electricity generation technology in China—a literature review. MDPI 10:1–15. <https://doi.org/10.3390/su10041181> [Google Scholar](#)

27. Greenpeace International (2015) The great water grab-how the coal industry is deepening the global water crisis. <http://www.greenpeace.org/archive-international/Global/international/publications/climate/2016/The-Great-Water-Grab.pdf>. Accessed 29 Oct 2018
28. Hamon group (2018) Natural draft cooling towers. <https://www.europages.co.uk/Natural-draft-cooling-towers/HAMON/cpid-5561189.html>. Accessed 11 Nov 2018
29. MoEFCC (2015) Notification on emission standards in coal power plants (Gazette Notification). Ministry of Environment, Forest and Climate Change, Government of India, New Delhi
30. Muthuraman M (2016) Reduction in power plant specific water consumption. Indian Power Stations - IPS 2016, Noida
31. Nexant, Inc (2014) Best practices manual for Indian supercritical plants
32. NITI Aayog (2018) Composite water management index- a tool for water management. New Delhi
33. Olsson E (2015) Water use in the chinese coal industry. Uppsala University, Uppsala [Google Scholar](#)
34. Perry RH, Green DW (2008) Psychrometry, evaporative cooling, and solids drying. In: Perry RH, Green DW, Maloney JO (eds) Perry's chemical engineers' handbook. McGraw-Hill, New York [Google Scholar](#)
35. Srinivasan S, Roshna N, Guttikunda SK et al (2018) Benefit cost analysis of emission standards for coal based thermal power plants in India. Center for Study of Science, Technology and Policy, Bangalore [Google Scholar](#)
36. Tianyi L, Krishnan D, Sen S (2018) Parched power: water demands, risks and opportunities for India's power sector. World Resource Institute, Washington DC [Google Scholar](#)
37. Xinxin Z, Junguo L, Yu T et al (2017) China's coal-fired power plants impose pressure on water resources. J Clean Prod. <https://doi.org/10.1016/j.jclepro.2017.04.040> [Google Scholar](#)
38. Zhai H, Rubin ES (2010) Performance and cost of wet and dry cooling systems for pulverized coal power plants with and without carbon capture and storage. Energy Policy 38:5653–5660. <https://doi.org/10.1016/j.enpol.2010.05.013> [Google Scholar](#)
39. Zhai H, Rubin ES (2016) A techno-economic assessment of hybrid cooling systems for coal- and natural-gas-fired power plants with and without carbon capture and storage. Environ Sci Technol 50:4127–4134. <https://doi.org/10.1021/acs.est.6b00008>
40. IPS Paul, A study of energy audit conservation and management measures in Indian thermal power stations for enhancing power generation, IEEE Workshop on Rtl& High Level Testing 2007;2(4):401-410.