

Implementation of Wireless Health Monitoring System using GSM Technology

¹Chidarapu Sravya; ²B. Ashok & ³G. Purna Chandra Rao

1. M.Tech, SVS Institute of Technology, Warangal, Hasanparthy, Bheemaram, Hanamkonda, Telangana 506015.
2. Associate Prof, SVS Institute of Technology, Warangal, Hasanparthy, Bheemaram, Hanamkonda, Telangana 506015.
3. Associate Prof, SVS Institute of Technology, Warangal, Hasanparthy, Bheemaram, Hanamkonda, Telangana 506015.

ABSTRACT-

The concept of this project builds upon the integration of wireless communications into medical applications to revolutionize personal healthcare. The objective of this project is to build a wireless heart beat monitoring system using GSM Technology, which could potentially be an integral part of a suite of personal healthcare appliances for a large-scale remote patient monitoring system. As its name implies this is a Health monitoring system, with a feature of sending SMS to doctor and information to corresponding nurse in the room through bluetooth and patients relative in event of emergency, hence the system can be used at hospitals as well as at home.

I. INTRODUCTION

Constant monitoring of the human's body parameters such as temperature, pulse rate, voltage etc. is a difficult task. Also in intensive care units it is necessary to monitor continuously the patient's health parameters and keep their record. There is possibility of human errors. There are some shortcomings present in existing system. Currently there are number of health monitoring systems available for the ICU patients which can be used only when the patient is on bed. This system has wiring complexities.

Such systems become difficult where the distance between System and PC is more. The available systems are huge in size. Regular monitoring of patient is not possible once he/she is discharged from hospitals. These systems cannot be used at individual level. Hence to remove human errors and to lessen excessive burden of continuously monitoring patient's health from doctor's head, we are proposing health monitoring system using GSM. The objective of Health monitoring system is to have quantitative assessment of important Physiological variables of patients during critical conditions. This system is used for measuring continuously automatically the values of the patient's important physiological parameters such as body temperature and pulse rate. The paper is organized into 6 sections. Section 1 gives an overview of the paper. Section 2 describes the basic block diagram of the Health Monitoring System. In section 3, different steps in the working of the system are presented. Section 4 is dedicated to the detailed explanation of the hardware used. Finally, section 5 presents conclusion and future work.

II. BLOCK DIAGRAM OF THE SYSTEM

Fig.1 shows a simplified block diagram where the blocks depict the major components of the system and their interconnections.

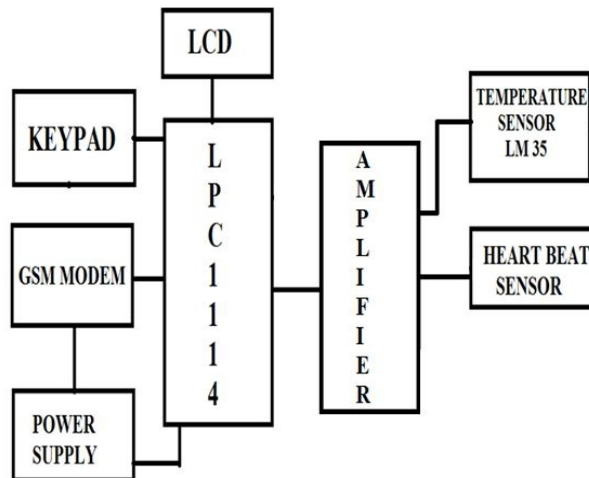
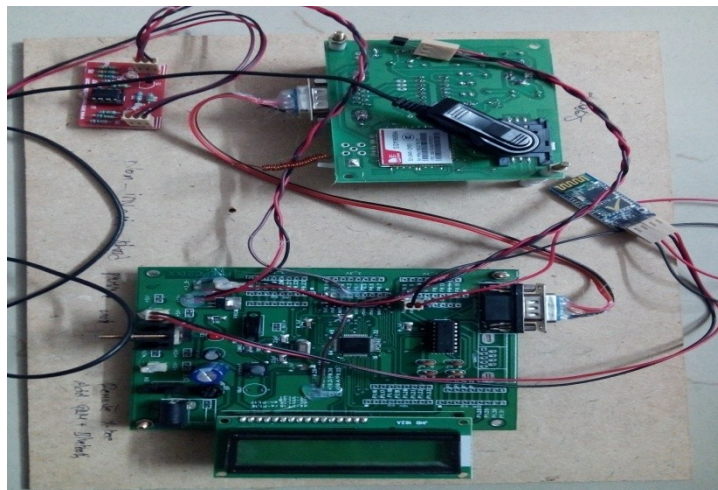
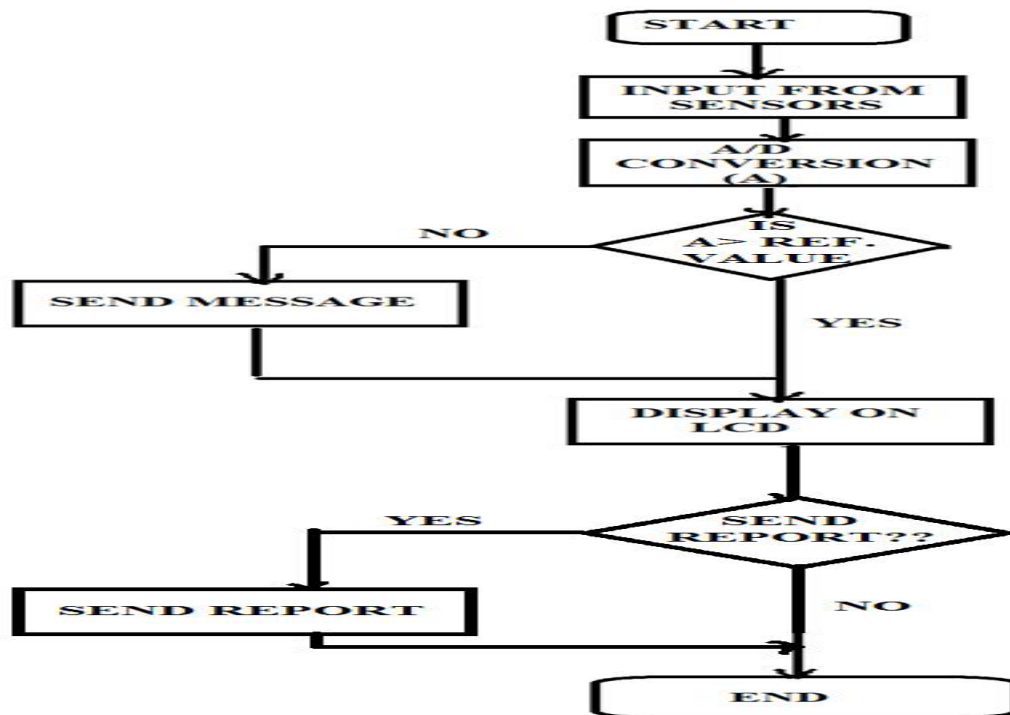

Fig.1 Block Diagram of Health Monitoring System

Various physiological signals such as body temperature and heart rate are continuously monitored with this system. Various types of transducers are used to sense these bioelectrical signals. To sense the body temperature we have used LM35 of national instruments because it is cheap in rate and its size is small enough to fit on patient's body. Heart beat sensor is one type of sensor which monitors the heart beat pulses for every minute. It will check the heart beat pulses and the same data will be given to LPC1114. This heart beat sensor is designed to give digital output of heart beat when a finger is placed inside it. This digital output can be connected to LPC1114 directly to measure the Beats per Minutes. All the signals from transducers are weak signals hence these signals are processed and amplified to desired level with the help of signal conditioner and instrumentation amplifier. The output of instrumentation amplifier is given to analog to digital converter. These converted digital signals are then fed to LPC 1114 which displays these respective values on LCD display and then compares these values with the hard coded values given to LPC1114. These values are stored in memory of LPC1114. If measured values cross the limit of reference values then LPC1114 sends SMS to a particular mobile number stored in memory through GSM modem. LPC1114 continuously displays these variables on the LCD Display. Also if the person wishes to send his report, he can do so on a regular basis by specifying his choice through keyboard. LPC1114 continuously does this work, thus providing a real time monitoring of heart rate, body temperature and voltage level of the battery

III. WORKING OF THE SYSTEM : Fig. 2 shows the flowchart of the health monitoring system.



In the first step, we sense the heart rate and body temperature using respective sensors.

Then, convert the analog data to digital using on chip ADC and compare the sensor values with the reference value using LPC1114. Next step is to send message through GSM to mentioned mobile number if the sensed value is found to be abnormal as well as display the message on LCD.

IV. HARDWARE USED

LPC1114: The LPC111x are a ARM Cortex-M0 based, low-cost 32-bit MCU family, designed for 8/16-bit microcontroller applications, offering performance, low power, simple instruction set and memory addressing together with reduced code size compared to existing 8/16-bit architectures. **Heart beat sensor:** Heart Beat Sensor consists of a super bright red LED and light detector. With each heart pulse the detector

signal varies. This variation is converted to electrical pulse. This signal is amplified and triggered through an amplifier which outputs +5V logic level signal. The output signal is also indicated on top by a LED which blinks on each heartbeat. The signals are analog which are converted into digital by ADC (Analog-Digital Converter), suitable for the MCU. **Temperature sensor:** LM35 temperature sensor is used to measure the temperature and connected to MCU. This sensor unit works under low power DC input of 5V which is controlled by a mini transformer.

Keypad and LCD: keypad and LCD are interfaced with the microcontroller for giving inputs and observing outputs.

A. Microcontroller: LPC1114

The basic features of LPC microcontroller include:

- System: ARM Cortex-M0 processor, running at frequencies of up to 50 MHz, ARM Cortex-M0 built-in Nested Vectored Interrupt Controller (NVIC), Serial Wire Debug, System tick timer.

- Memory: 32 kB (LPC1114), on-chip flash programming memory.

8 kB, 4 kB, or 2 kB SRAM, In-System Programming (ISP) and In-Application Programming (IAP) via on-chip Boot loader software.

- Digital peripherals:

Up to 42 General Purpose I/O (GPIO) pins with configurable pull-up/pull-down resistors, GPIO pins can be used as edge and level sensitive interrupt sources, high-current output driver (20 mA) on one pin, high-current sink drivers (20 mA) on two I2C-bus pins in Fast-mode Plus, four general purpose timers/counters with a total of four capture inputs and 13 match outputs, Programmable Watchdog Timer (WDT).

- Analog peripherals:

10-bit ADC with input multiplexing among 8 pins.

- Serial interfaces:

UART with fractional baud rate generation, internal FIFO, and RS-485 support, two SPI controllers with SSP features and with FIFO and multi-protocol capabilities (second SPI on LQFP48 and PLCC44 packages only), I2C-bus interface supporting full I2C-bus specification and Fast-mode Plus with a data rate of 1 Mbit/s

with multiple address recognition and monitor mode.

- Power control:

Integrated PMU (Power Management Unit) to minimize power consumption during Sleep, Deep-sleep, and Deep power-down modes, three reduced power modes: Sleep, Deep-sleep, and Deep power-down, processor wake-up from Deep-sleep mode via a dedicated start logic using up to 13 of the functional pins, Power-On Reset (POR), Brownout detect with four separate thresholds for interrupt and forced reset.

B. Temperature Sensor :The temperature and heart beat sensors can measure temperature, pulse signals which are sent to the microcontroller. The sensors are connected to the I/O port of the microcontroller LPC1114. It is electronic device which provides a voltage analogue of the temperature of the surface on which it is mounted. The LM35 series are precision integrated-circuit Temperature Sensors whose output voltage is linearly proportional to the Celsius temperature. The sensor circuitry is sealed and not subject to oxidation. The LM35 generates a higher output voltage than thermocouples and may not require that the output voltage be amplified. The output voltage is converted to temperature by a simple conversion factor. Normally the body temperature for a normal adult is about 35 degree Celsius.

The general equation used to convert output voltage to temperature is: Temperature (oC) = $V_{out} * (100 \text{ oC/V})$ So if V_{out} is 1V, then, Temperature = 100 oC. The output voltage varies linearly with temperature.

Fig.3 shows the LM35 temperature sensor.

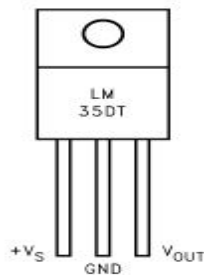

C. Heart Beat Sensor

Heart beat sensor is one type of sensor which monitors the heart beat pulses for every minute. It will check the heart beat pulses and the same data will be given to Microcontroller. This heart beat sensor is designed to give digital output of heart beat when a finger is placed inside it as shown in fig.4. This digital output can be connected to Microcontroller directly to measure the Beats per Minutes

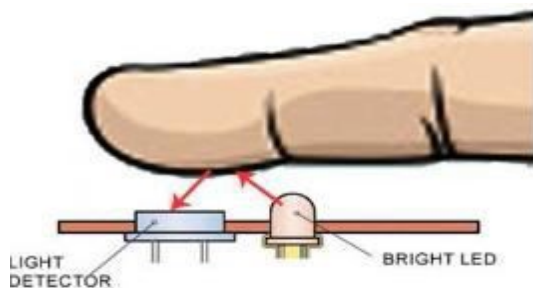

Working of heart beat sensor: Fig.5 shows the circuit diagram of the heart beat sensor. The sensor consists of a super bright red LED and light detector. The LED needs to be super bright as the light must pass through finger and detected at other end. When the heart pumps a pulse of blood through the blood vessels, the finger becomes slightly more opaque and so less light reached the detector. With each heart pulse the detector signal varies. This variation is converted to electrical pulse. This signal is amplified and triggered through an amplifier which outputs +5V logic level signal. The output

signal is also indicated on top by a LED which blinks on each heartbeat.

CONCLUSION

By using this prototype circuit containing LPC1114, GSM Modem, LCD and other hardware circuit so that the page messages can be transferred at fixed time intervals to the corresponding medical expert to give necessary precautions to take care about the patient. This system has the following features:

i. LPC1114 MCU consumes low power with suitable devices for interconnection.

ii. Continuous monitoring of patients is done

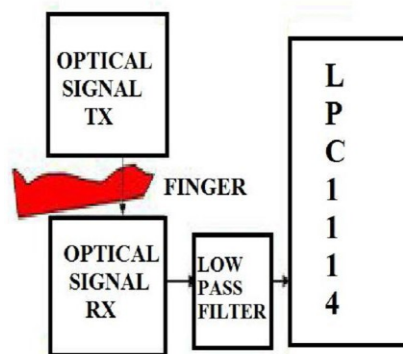

which is simple by using GSM network. The device is designed to provide a continuous access to a

person's heart rate and temperature monitoring & inform through wireless communication. The heart beat sensor which detects heart beat is interfaced to microcontroller along with LCD, which display the heart beat rate. The goal of the project is to reduce the hospitalization and assistance cost. Health monitoring application is mainly proposed to provide alerts for medical health monitoring staff for the patients when needed.

REFERENCES

[1] Chaya Khandelwal S. and Manish Patil M., Implementation of Patient Monitoring System Using GSM Technology, International Journal of

Electronics and Communication technology, 4(1)
18-24 (2013).

[2] Qun Hou, Research and Implementation of Remote Heart Rate Monitoring System Based on GSM and MCU, Institute of Electrical and Electronics Engineers, 978-1-4244- 7618-3 (2010).

[3] Edwards S., Heart rate Monitor Book”, Leisure systems international, 1(3), 122-134 (1993)

[4] Chiranjeevini Kumari B. and Rajasekar K., Implementation of SMS based Heartbeat monitoring system using PSoC Microcontroller, 2230-7109, International Journal of Electronics and Communication technology, 2(1), (2011)

[5] Mohammad Ari Mazidi and Janci Gillispie, The 8051 Microcontroller and Embedded Systems, (2), 5-17 (2007)

[6] Lee. W.C.Y, Mobile Cellular Telecommunications, (2), 463-467 (1995)