

Intelligent Grid to Autonomous Cars and Vehicular through wireless communication

¹Gottymukkula Sowjanya & ²Padakanti Kiran Kumar

1. M.Tech, Balaji Institute of Technology & Science (BITS) , Maheswaram (P), Narsampet Mandal, Warangal Dist.-506 331, Warangal-Narsampet Rd, Madhira D, Telangana 506330.
- 2.Asst. Professor, Balaji Institute of Technology & Science (BITS) -, Maheswaram (P), Narsampet Mandal, Warangal Dist.-506 331, Warangal-Narsampet Rd, Madhira D, Telangana 506330

ABSTRACT:

Traditionally, the vehicle has been the extension of the man's ambulatory system, docile to the driver's commands. Recent advances in communications, controls and embedded systems have changed this model, paving the way to the Intelligent Vehicle Grid. The urban fleet of vehicles is evolving from a collection of sensor platforms to the Internet of Autonomous Vehicles. Like other instantiations of the Internet of Things, the Internet of Vehicles will have communications, storage, intelligence and learning capabilities to anticipate the customers' intentions. This article claims that the Vehicular Cloud, the equivalent of Internet Cloud for vehicles, will be the core system environment that makes the evolution possible and that the autonomous driving will be the major beneficiary in the cloud architecture.

INTRODUCTION:

In the vehicular network, like in all the other IOTs, when the human control is removed, the autonomous vehicles must efficiently cooperate to maintain smooth traffic flow in roads and highways. Visionaries predict that the vehicles will behave much better than drivers allowing to handle more traffic with lower delays, less pollution and certainly better driver and passenger comfort. However, the complexity of

the distributed control of hundreds of thousands of cars cannot be taken lightly. If a natural catastrophe suddenly happens, say an earthquake, the vehicles must be able to coordinate the evacuation of critical areas in a rapid and orderly manner.

This requires the ability to efficiently communicate with each other and also to discover where the needed resources are (e.g., ambulances, police vehicles, information about escape routes, images about damage that must be avoided, etc.). Moreover, the communications must be secure, to prevent malicious attacks that in the case of autonomous vehicles could be literally deadly since there is no standby control and split second chance of intervention by the driver (who may be surfing the web). Vehicles produce a great amount of content, while at the same time consuming the content. That is, they become rich data "prosumers." Such contents show several common properties of local relevance - local validity, explicit lifetime, and local interest. *Local validity* indicates that vehicle-generated content has its own spatial scope of utility to consumers. In safety applications, for instance, a speed-warning message near a sharp corner is only valid to vehicles approaching to the corner, say within 100 m. *Explicit lifetime* reflects the

fact that vehicle content has its own temporal scope of validity. This also implies that the content must be available during its entire lifetime. For instance, the road congestion information may be valid for 30 min, while the validity of roadwork warning must last as long as work is finished. *Local interest* indicates that nearby vehicles represent the bulk of potential content consumers. This concept is further extended so as to distinguish the scope of consumers. For instance, all the vehicles in the vicinity want to receive safety messages, while only a fraction of vehicles are interested in commercial advertisements. Timespace validity of the data implies the scalability of the data collection/storage/processing applications, since old data is discarded. It also implies that the data should be kept on the vehicles rather uploaded to the Internet, leading to enormous spectrum savings. This property will be key to the scalability of the autonomous vehicle concept, given the huge amount of data collected by autonomous vehicle sensors. This memoryless property is characteristic of VANETs. In the fixed Internet, when one wants to check traffic congestion, she visits a favorite service site. Namely, the explicit site's URL guarantees access to ample, reliable information. In contrast, vehicle applications flood query messages to a local area, not to a specific vehicle, accepting responses regardless of the identity of the content providers. In fact, the response may come from a vehicle in the vicinity that has in turn received such traffic information indirectly through neighboring vehicles. In this case, the vehicle does not care who started the broadcast. This characteristic is mainly due to the fact that the sources of information (vehicles) are mobile and geographically scattered. Content centric

networking will play a major role in the management and control of the autonomous car fleet. There are two reasons for this: first, the autonomous vehicle will travel at high speed and short distance from neighbors (on highways) and must have very up-to-date information of surrounding vehicles up to several kilometers in order to maintain a stable course. Thus, in the content-centric networking style,

HARDWARE IMPLEMENTATION:

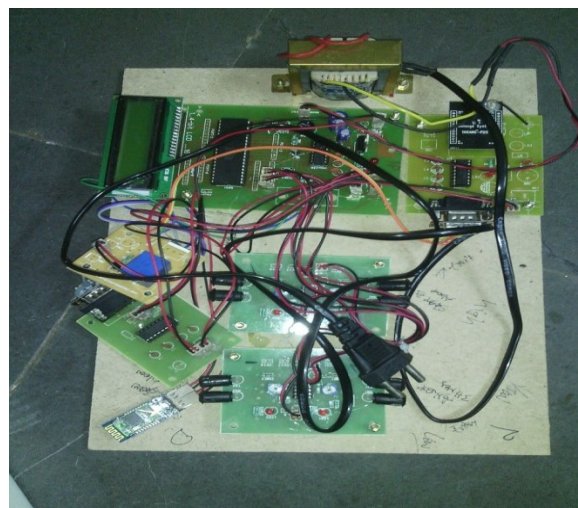

ARM7

The ARM7 family includes the ARM7TDMI, ARM7TDMI-S, ARM720T, and ARM7EJ-S processors. The ARM7TDMI core is the industry's most widely used 32-bit embedded RISC microprocessor solution. Optimized for cost and power-sensitive applications, the ARM7TDMI solution provides the low power consumption, small size, and high performance needed in portable, embedded applications.

The ARM7EJ-S processor is a synthesizable core that provides all the benefits of the ARM7TDMI low power consumption, small size, and the thumb instruction set while also incorporating ARM's latest DSP extensions and enabling acceleration of java-based applications. Compatible with the ARM9™, ARM9E™, and ARM10™ families, and Strong-Arm® architecture software written for the ARM7TDMI processor is 100% binary-compatible with other members of the ARM7 family and forwards-compatible with the ARM9, ARM9E, and ARM10 families, as well as products in Intel's Strong ARM and x scale architectures. This gives designers a choice of software-compatible processors with strong price-performance points. Support for the ARM architecture today includes:

- Operating systems such as Windows CE, Linux, palm and SYMBIAN OS.
- More than 40 real-time operating systems, including qnx, Wind River's vxworks and mentor graphics' vrtx.

- Co simulation tools from leading eda vendors
- A variety of software development tools.

MAX232

The MAX232 is an integrated circuit that converts signals from an RS-232 serial port to signals suitable for use in TTL compatible digital logic circuits. The MAX232 is a dual driver/receiver and typically converts the RX, TX, CTS and RTS signals.

The drivers provide RS-232 voltage level outputs (approx. ± 7.5 V) from a single +5 V supply via on-chip charge pumps and external capacitors. This makes it useful for implementing RS-232 in devices that otherwise do not need any voltages outside the 0 V to +5 V range, as power supply design does not need to be made more complicated just for driving the RS-232 in this case.

PIN DIAGRAM OF MAX232

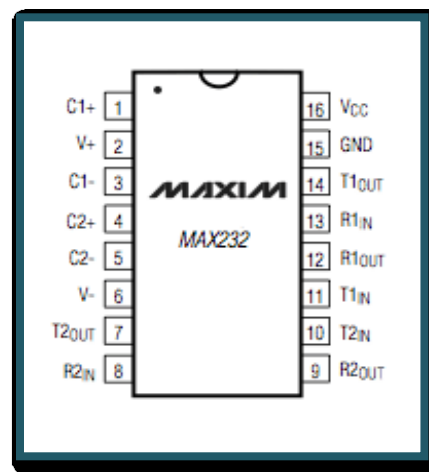

• Fig 4.2: Pin Diagram of MAX232.

RS232 Interfaced to MAX 232

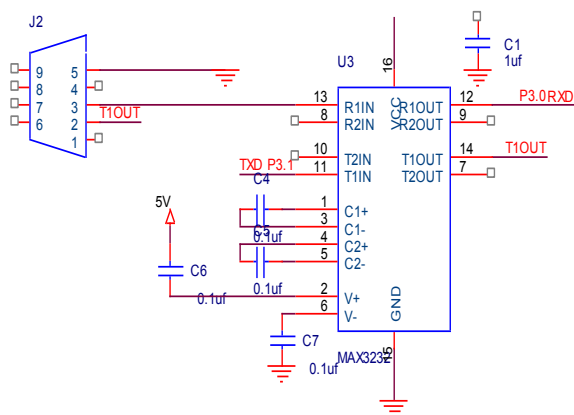

Fig 4.3: RS232 Interfaced to MAX232.

- RS232 is 9 pin db connector, only three pins of this are used ie 2,3,5 the

Table 4.2: TTL Logic Levels

RS232 Line Type & Logic Level	RS232 Voltage	TTL Voltage to/from MAX232
Data Transmission (Rx/Tx) Logic 0	+3V to +15V	0V
Data Transmission (Rx/Tx) Logic 1	-3V to -15V	5V
Control Signals (RTS/CTS/DTR/DSR) Logic 0	-3V to -15V	5V
Control Signals (RTS/CTS/DTR/DSR) Logic 1	+3V to +15V	0V

ZIGBEE:

ZigBee was designed to provide high data throughput in applications where the duty cycle is low and low power consumption is an important consideration. (Many devices that use ZigBee are powered by battery.) Because ZigBee is often used in industrial automation and physical plant operation, it is often associated with machine-to-machine (M2M) communication and the Internet of Things (IoT).

ZigBee is based on the Institute of Electrical and Electronics Engineers Standards

transmit pin of RS232 is connected to Rx pin of MAX232.

3.3.2 VOLTAGE LEVELS

It is helpful to understand what occurs to the voltage levels. When a MAX232 IC receives a TTL level to convert, it changes a TTL Logic 0 to between +3 and +15V, and changes TTL Logic 1 to between -3 to -15V, and vice versa for converting from RS232 to TTL. This can be confusing when you realize that the RS232 Data Transmission voltages at a certain logic state are opposite from the RS232 Control Line voltages at the same logic state. To clarify the matter, see the table below.

Association's 802.15 specification. It operates on the IEEE 802.15.4 physical radio specification and in unlicensed radio frequency bands, including 2.4GHz, 900 MHz and 868 MHz. The specifications are maintained and updated by the ZigBee Alliance.

As of this writing, there are three ZigBee specifications: ZigBee, ZigBee IP and ZigBee RF4CE. ZigBee IP optimizes the standard for IPv6 full mesh networks and ZigBee RF4CE optimizes the standard for partial mesh networks.

Conclusion:

The urban fleet of vehicles is evolving from a collection of sensor platforms to the Internet of Autonomous Vehicles. Like other instantiations of the Internet of Things, the Internet of Vehicles will have communications, storage, intelligence and learning capabilities to anticipate the customers' intentions. The car is now a formidable sensor platform, absorbing information from the environment (and from other cars) and feeding it to drivers and infrastructure to assist in safe navigation, pollution control and traffic management. The next step in this evolution is just around the corner: the Internet of Autonomous Vehicles. Pioneered by the Google car, the Internet of Vehicles will be a distributed transport fabric capable to make its own decisions about driving customers to their destinations. Like other important instantiations of the Internet of Things (e.g., the smart building), the Internet of Vehicles will have communications, storage, intelligence, and learning capabilities to anticipate the customers' intentions. The concept that will help transition to the Internet of Vehicles is the Vehicular Cloud, the equivalent of Internet cloud for vehicles, providing all the services required by the autonomous vehicles. In this article, we discuss the evolution from Intelligent Vehicle Grid to Autonomous, Internet-connected Vehicles, and Vehicular Cloud.

REFERENCES

- [1] U. Lee, E. Magistretti, B. Zhou, M. Gerla, P. Bellavista, and A. Corradi, "MobEyes: Smart Mobs for Urban Monitoring with a Vehicular Sensor Network," *IEEE Communications Magazine*, vol. 13(6), pp. 52 – 57, Oct. 2006.
- [2] S. Kumar, L. Shi, S. Gil, N. Ahmed, D. Katabi, and Daniela, "CarSpeak: A Content-Centric Network for Autonomous Driving," in *ACM SIGCOMM*, Aug. 2012.
- [3] "Smart Dust Project," <http://robotics.eecs.berkeley.edu/~pister/SmartDust/>.
- [4] E.-K. Lee, Y. M. Yoo, C. G. Park, M. Kim, and M. Gerla, "Installation and Evaluation of RFID Readers on Moving Vehicles," in *ACM VANET*, Sep. 2009.
- [5] M. Gerla, "Vehicular Cloud Computing," in *IEEE Med-Hoc-Net*, June 2012.
- [6] N. Fernando, S. Loke, and W. Rahayu, "Mobile Cloud Computing: A Survey," *Elsevier Future Generation Computer Systems*, vol. 29(1), pp. 84 – 106, July 2013.
- [7] B. Ahlgren, C. Dannewitz, C. Imbrenda, D. Kutscher, and B. Ohlman, "A Survey of Information-Centric Networking," *IEEE Communications Magazine*, vol. 50(7), pp. 26 – 36, July 2012.
- [8] V. Jacobson, D. K. Smetters, J. D. Thornton, M. F. Plass, N. H. Briggs, and R. L. Braynard, "Networking Named Content," in *ACM CoNEXT*, Dec. 2009.
- [9] L. Wang, R. Wakikawa, R. Kuntz, R. Vuyyuru, and L. Zhang, "Data naming in Vehicle-to-Vehicle communications," in *IEEE NOMEN*, Mar. 2012.