

# Bank Locker Authentication using Signature Verification on Mobile phones

**Lakshmi kala Pampana <sup>1</sup>& Gandla Naga Sandeep <sup>2</sup>**

<sup>1</sup>ASSISTANT PROFESSOR, Dept of ECE, MLRITM, Hyderabad, Telangana

<sup>2</sup>PG Student [Embedded Systems], MLRITM, Hyderabad, Telangana

Mail id's: lakshmisurendra2007@mlritm.ac.in<sup>1</sup>, nagasandeep456.g@gmail.com<sup>2</sup>

## Abstract—

*A 2-step authentication is designed for giving security to the bank lockers. First step is through password and the second step is through signature verification. Signature is collected with the help of Android Smartphone from the user and it is uploaded to the dynamic web server for image processing using open CV (Histogram Evaluation). If it matches with the original signature given during opening of the account, then the locker can be accessed.*

**Keywords—** Android Application; open CV; Signature Verification; Histogram Evaluation

## I. INTRODUCTION

Now-a-days, the bank lockers were accessed through a key and there were some demerits by doing that. Out of which, the main demerit is anyone can access the locker if they have a key with them. In this paper, we proposed a solution for bank lockers. A security system is designed with 2-step authentication (Step-1: Password Recognition, Step-2: Pattern Recognition). Pattern Recognition is done with the help of user signature verification using image processing. OpenCV installed with Microsoft Visual Studio 2012 is used for processing the signature and a simple customized web bank interface is also designed along with the android application.

Signature Verification can be done in two ways:

*Static:* In this verification method, users deliver their signature on a bank document and digitalize it through a scanner. Bankers will

recognizes it through a shape analysis. Thus, this method is termed as offline system.

*Dynamic:* In this verification method, users deliver their signature on an android smartphone/any digitalized device and that signature will be given for image processing with the previous original signature where pattern recognition plays a vital role and making it as an online system.

## II. SYSTEM ARCHITECTURE

The system architecture of this proposed system is divided into three different and independent blocks. *ARM7 END:* Hardware implementation for this proposed system is shown below with the simple blocks. Power Supply block is designed and developed to generate power source for the ARM processor and its relevant components. Reset Circuit is designed and developed to reset the program whenever necessary and interfaced to the ARM processor for greater stable response. Clock Circuit is designed and developed to generate oscillations and interfaced to the ARM processor for needy response. LCD Display is interfaced to the ARM processor for displaying the status of the system for better understanding. Keypad is used to enter the password as a first step authentication for bank lockers which plays a key role in accessing the locker. The GSM module is the main important peripheral which sends information to the owner asking him to sign on his own android smartphone, the system which we proposed here seems to look like a present

OTP system. Laptop is interfaced for processing the image.

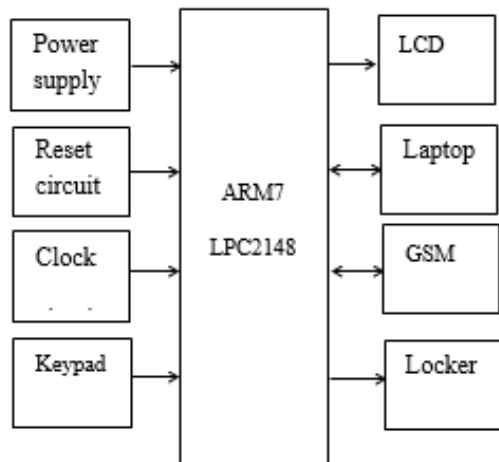

Figure – 1: Block Diagram of ARM7 END

**ANDROID END:** The GSM module interfaced at ARM will send a simple SMS stating that someone is accessing the locker, and please authenticate it with the help of your signature. A simple customized Android application is designed and installed manually in the user's android smartphone/tablet. The GSM module of android smartphone will receive a SMS coming from ARM end, upon a SMS coming from the bank server a simple android application will be opened automatically. In the application, it will ask you to enter your name and followed by a canvas where the user has to sign there. The signed image will be uploaded to the bank server for signature verification.

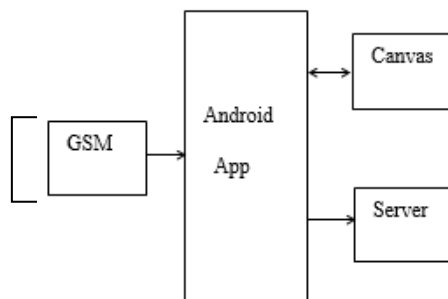

Figure – 2: Block Diagram of ANDROID END

**SERVER END:** A WEB SERVER is designed and developed for collecting the user signature from the application. A simple UI is designed for better understanding by the bankers and when the signature is received, the bankers will perform the signature verification using openCV. Manual UI is designed for understanding of process with the help of HTML and PHP.

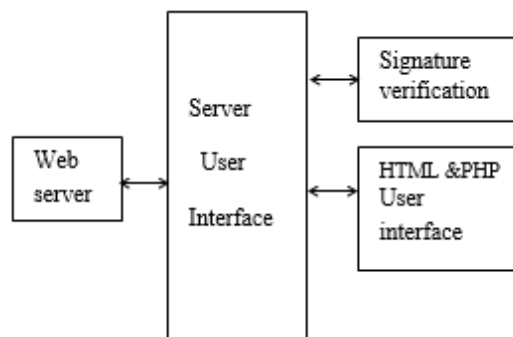

Figure – 3: Block Diagram of Server END

### III. IMPLEMENTATION

#### HARDWARE:

In hardware implementation, ARM processor plays a key role in monitoring and controlling the security system. Low-power consumption ARM processor (LPC2148) operating at 3.3V, 50uA is designed and mounted on a PCB along with Reset Circuit and a Clock Circuit. LPC2148, a 32-bit microcontroller with advanced RISC architecture and having 48 GPIO lines with a program memory of 32KB and a data memory of 512Bytes.

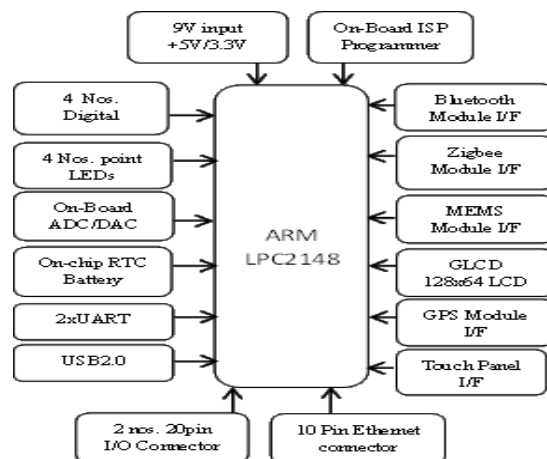

Figure – 4: ARM Overview [LPC2148]

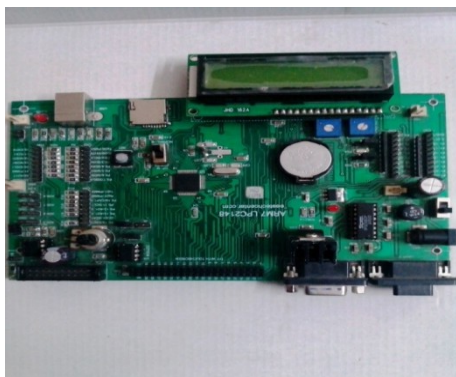

Figure – 5: LPC2148 Development Board

Here, in the above figure the clock circuit and reset circuits were assembled along with the LCD display circuit. A 16 X 2 LCD display is used for displaying the status of the system. A keypad is also designed as per below the schematic diagram, and interfaced to P0.16 – P0.23 of LPC2148.

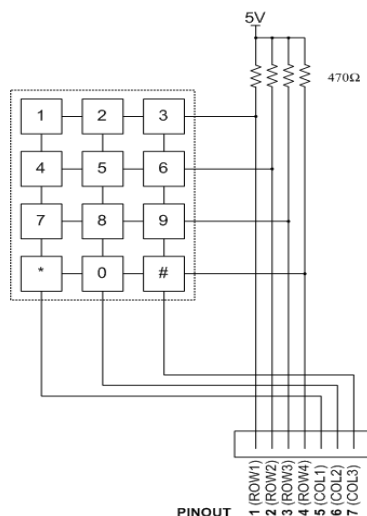

Figure – 6: Keypad Interfacing with LPC2148

The remaining modules like GSM, Motor Driver for controlling the locker were assembled as per the following schematic diagram:

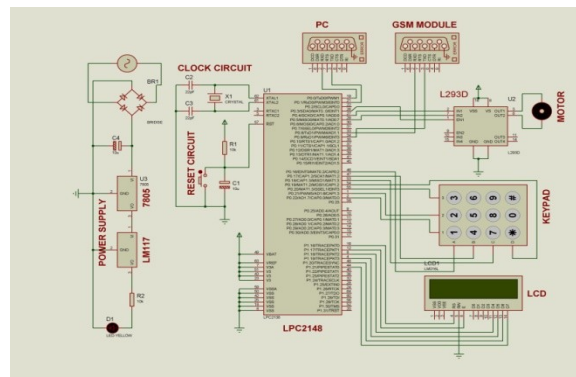

Figure – 7: Schematic Diagram

PC/Laptop was interfaced at UART0 of LPC2148 as per Figure – 7. Motor was interfaced to L293D (Motor Driver) at P0.3 – P0.5 of LPC2148 as per Figure – 8 which enables the locker action. GSM Module was interfaced to UART1 for SMS communication. Keypad (4 \* 3) was interfaced at P0.16 – P0.23 of LPC2148. LCD Display (16 \* 2) was also interfaced at P1.6 – P1.22 of LPC2148. Reset Circuit and Clock Circuits were interfaced at RST, XTAL1, and XTAL2 of LPC2148.

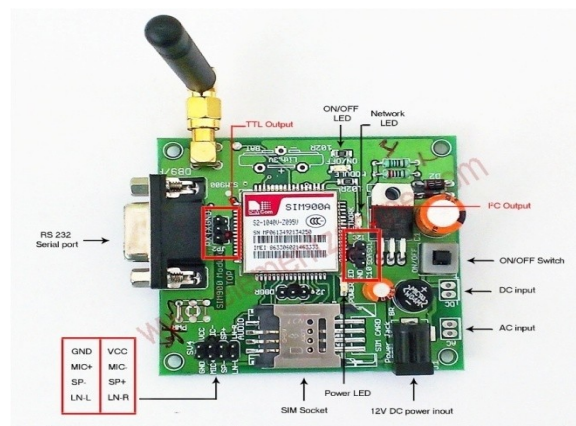

Figure – 8: GSM Module

**SOFTWARE:**

Here, to program ARM processor Keiluvision 4 was used as a cross-compiler and Flash Magic was used as a programmer. Signature evaluation is done using openCV with Visual





**V. RESULTS**

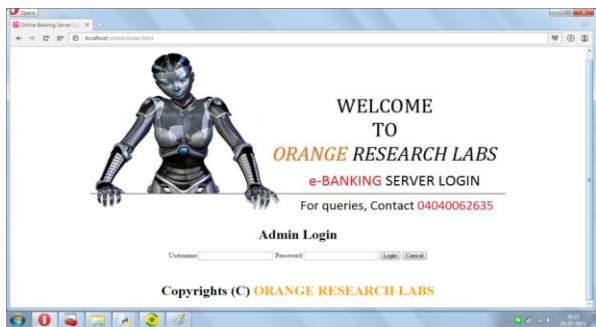

Figure – 10: Server Login of Bank

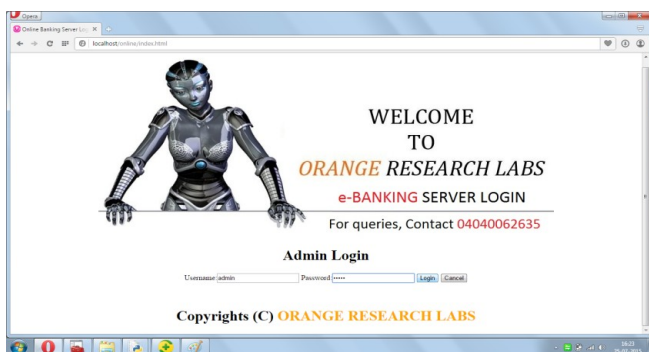

Figure – 11: Login ID and Password

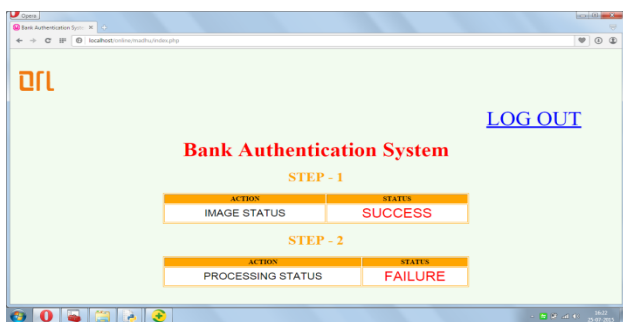

Figure – 12: Status of the Process

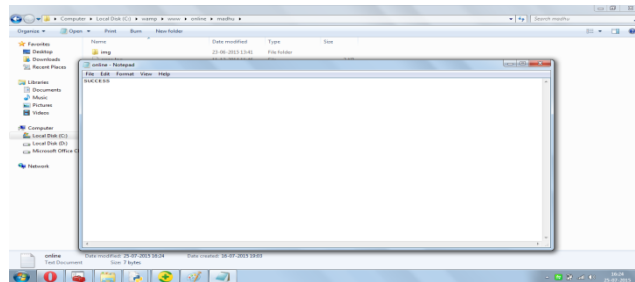

Figure – 14: Text Bridge between the HTML and Image Processing

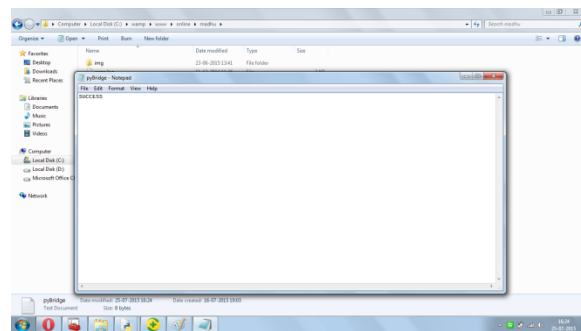

Figure – 15: Python Bridge between the Python Program and Serial Communication

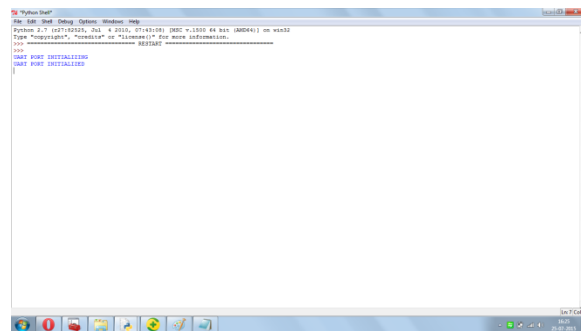

Figure – 16: Python Web Server

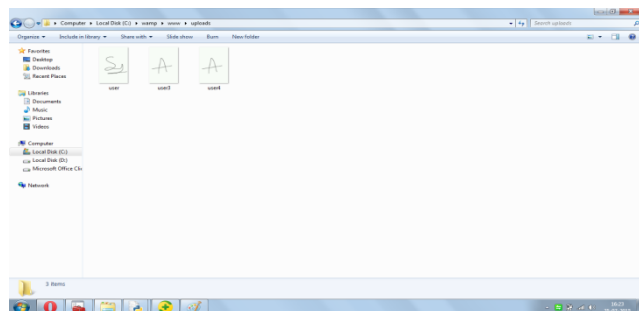

Figure – 13: Signature Uploaded to the server

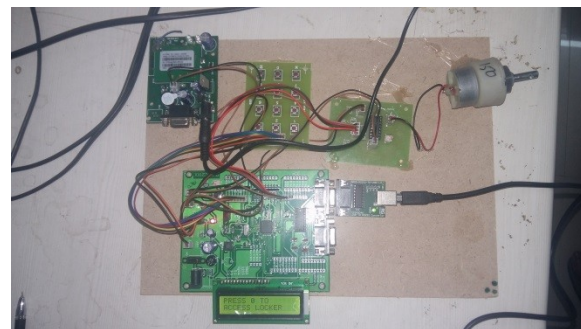

Figure – 17: Hardware Assembled for the system



Figure – 18: Asking to access the locker



Figure – 22: Waiting for the server to communicate



Figure – 19: Enter the password



Figure – 23: Unauthorized access



Figure – 20: Entering the password



Figure – 24: Signature collected from Android Smartphone



Figure – 21: Authorized and going to second authentication

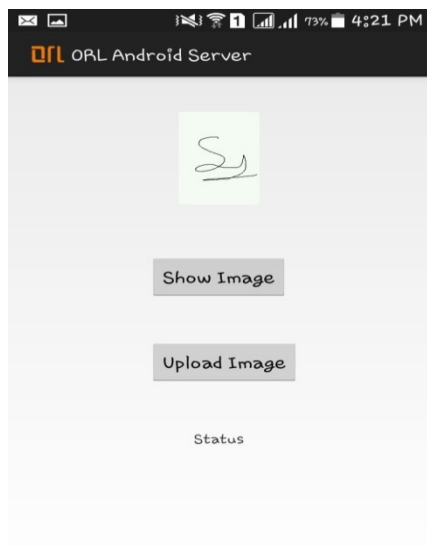

Figure – 25: Signature Stored

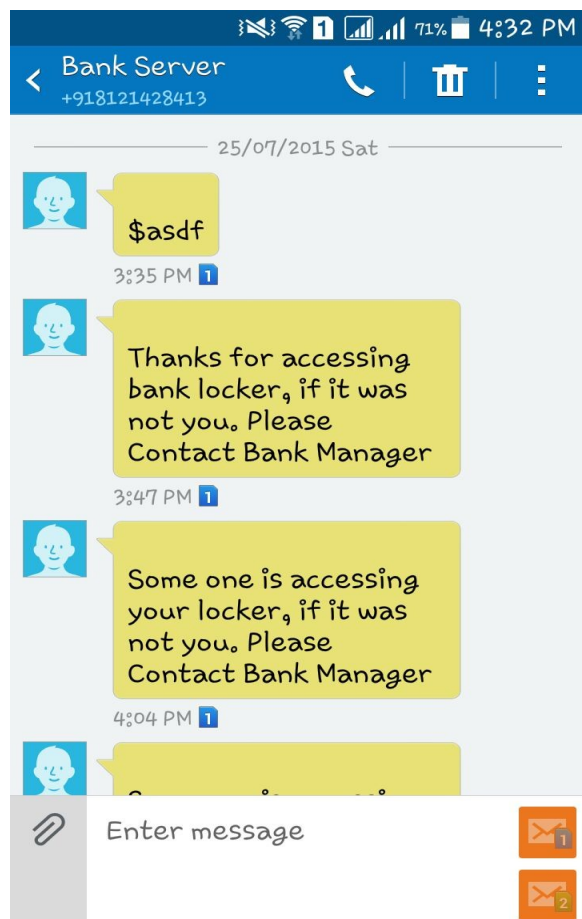

Figure – 26: SMS Feedback from the server

## VI. CONCLUSION

Here, in this paper a two-step authentication is designed and proposed for accessing the locker in the bank with a password and signature verification as authentications. Now-a-days, digitalization is everywhere and in every digital product that designed and purchased. Making a signature on a digital device plays a key role in making authentications for various applications and field areas.

## ACKNOWLEDGEMENT

I would like to express my special thanks of gratitude to Marri Laxman Reddy Institute of Technology & Management as well as our Principal Dr. K Venkateswara Reddy, M. Tech., Ph.D., MISTE, K. N. BHUSHAN, Assoc. Prof & HOD ECE, Asst Prof P. Lakshmi kala, Dept of ECE, MLRITM college, who gave me the golden opportunity to do this wonderful project on the topic (Bank locker authentication using signature verification on mobile phones), which also helped me in doing a lot of Research and i came to know about so many new things we are really thankful to them.

And, secondly i would also like to thank my parents and friends who helped me a lot in finalizing this project within the limited time frame.

## REFERENCES

- [1] L. Nanni and A. Lumini, "A novel local online signature verification system", vol 29. No 5 pp – 599-568, 2008.
- [2] E. Maiorana, P. Campisi, J. Fierrez, J. Ortega-Garcia, and A. Neri, "Cancelable templates for sequence-based biometrics with application to online signature recognition," IEEE Trans. Syst.,

Man, Cybern. A, Syst.,Humans, vol. 40, no. 3, pp. 525–538, May 2010.

[3]H. Feng and C. C. Wah, “Online signature verification using a newextreme points warping technique,” Pattern Recognit.Lett., vol. 24,no. 16, pp. 2943–2951, 2003.

[4]DataGenetics. (2012, Aug. 14). Pin Analysis [Online].

Available:<http://www.datagenetics.com/blog/september32012/>

[5] Python Reference – Guido Van Rossum, Fred L. Drake, Jr., editor, Available: <https://docs.python.org/2.0/ref/ref.html>

[6] Py Serial – Documented for Python Serial. Available: <http://pythonhosted.org/pyserial/>

[7] PHP References manual for Beginners, Available: <http://code.stephenmorley.org/php/references-tutorial/>

[8] Managing Android Projects for Beginners, Available: <https://www.edx.org/course/introduction-mobile-application-hkustx-comp107x?gclid=CKawudvN-8YCFYcHvAodMeYGLw>

[9] Referenced GSM, AT COMMANDS Available: <http://www.zeeman.de/wp-content/uploads/2007/09/ubinetics-at-command-set.pdf>

[10] ARMv7 Reference and System Architecture Manual, Available: [https://web.eecs.umich.edu/~prabal/teaching/eecs373-f10/readings/ARMv7-M\\_ARM.pdf](https://web.eecs.umich.edu/~prabal/teaching/eecs373-f10/readings/ARMv7-M_ARM.pdf)

SYSTEM DESIGN and B.Tech in ECE from Sri Vishnu Engineering College .



Mr.G.Nagasandeep had completed B.Tech in ECE from Shri Sai Institute of Engineering & Technology. He is perusing M.Tech in Embedded Systems from MLRITM College.



## BIOGRAPHY

Asst Prof.P Lakshmi Kala has completed M.TECH from Indur Institute Of Technology in VLSI