



Comparative Study of Reducing the Fault Current and Overvoltage in a Distribution System in Autonomous Micro Grids Operation Using PSO UPFC & SFCL

Vukoti Madhuri*¹; Abdul Ahad²& Dr. Abdul Ahad³

¹M.tech (P.S) Student Department Of EEE, Nimra College Of Engineering & Technology
madhurivukoti@gmail.com

² Asst. Professor Department Of EEE, Nimra College Of Engineering & Technology

³Professor & Head Of The Department, Nimra College Of Engineering & Technology

ABSTRACT:

This paper deals with a hybrid active power filter with injection circuit (IHAPF). It shows great promise in reducing harmonics and improving the power factor with a relatively low capacity active power filter. This paper concluded that the stability of the IHAPF based on detection supply current is superior to that of others. To minimize the capacity of IHAPF, an adaptive fuzzy dividing frequency-control method is proposed by analyzing the bode diagram, which consists of two control units: a generalized integrator control unit and fuzzy adjustor unit. The generalized integrator is used for dividing frequency integral control, while fuzzy arithmetic is used for adjusting proportional-integral coefficients timely. And the control method is generally useful and applicable to any other active filters. The strategy was proposed for four- and three-wire systems, and it allowed the compensation of current harmonics and reactive power of harmonic current source and harmonic voltage source loads. Compared to other IHAPF control methods, the adaptive fuzzy dividing frequency control shows the advantages of shorter response time and higher control precision. The simulation results show that the new control method is not only easy to be calculated and implemented, but also very effective in reducing harmonics.

INTRODUCTION

In order to solve more serious harmonic problems of the grid, the passive power filter (PPF) is often used at the point of common coupling (PCC) conventionally. However, it has many disadvantages (mistuning, resonance, instability, etc.), which discourages its implementation. The use of the active power filter (APF) to mitigate harmonic problems has drawn much attention since the 1970s. APFs seem to be a feasible solution for eliminating harmonic currents and voltages. They are usually in parallel to harmonic loads and, therefore, are called shunt APFs. In recent years,

there has been a trend to develop the shunt APF that can be used under non-sinusoidal supply voltages, where the voltages at the PCC of the APF are harmonics-contaminated and caused by other connecting nonlinear loads in the APF application environment. However, they are limited by high cost, low-power capacity, and are difficult to use in high-voltage grids. Another solution for the harmonic problem is to adopt a hybrid active power filter (HAPF). The HAPF is the combination of active and passive power filters. The aim in the HAPF design is to complement or enhance the performance of the active power filter

or passive power filter by adding passive or active components to its structure.

FUZZY LOGIC

In recent years, the number and variety of applications of fuzzy logic have increased significantly. The applications range from consumer products such as cameras, camcorders, washing machines, and microwave ovens to industrial process control, medical instrumentation, decision-support systems, and portfolio selection. To understand why use of fuzzy logic has grown, you must first understand what is meant by fuzzy logic.

Fuzzy logic has two different meanings. In a narrow sense, fuzzy logic is a logical system, which is an extension of multivalve logic. However, in a wider sense fuzzy logic (FL) is almost synonymous with the theory of fuzzy sets, a theory which relates to classes of objects with unsharp boundaries in which membership is a matter of degree. In this perspective, fuzzy logic in its narrow sense is a branch of fl. Even in its more narrow definition, fuzzy logic differs both in concept and substance from traditional multivalve logical systems.

I. SYSTEM CONFIGURATION AND CONTROL STRATEGY

A. Topology of the Novel HAPF

The parallel HAPF has the advantages of easy installation and maintenance and can also be made just by transformation on the PPF installed in the grid. Fig. 1 shows a PHAPF that is in use now.

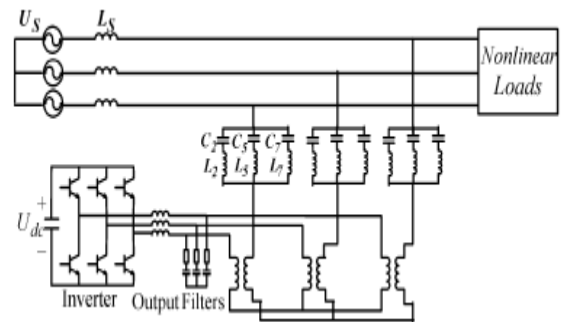

Fig.1 Topology of the shunt hybrid APF

To reduce the power of APFs, a PPF has been designed for some certain orders of harmonics. As in Fig., $C_2, L_2; C_5, L_5,$ and C_7 and L_7 make up a PPF to compensate the second, fifth, and seventh harmonic current, while the APF is just used to improve the performance of PPF and get rid of the resonance that may occur. So the power of the filter can be reduced sharply, usually one-tenth of the power of the nonlinear load, which enables the APF to be used in a high-power occasion. HAPF is expected to compensate for reactive power as well as damp harmonics in the grid, and all of the reactive power current will go through APF. To further decrease the power of APF, a novel configuration of the hybrid APF is proposed. L_1 and C_1 tune at the fundamental frequency, and then compose the injection branch with C_F .

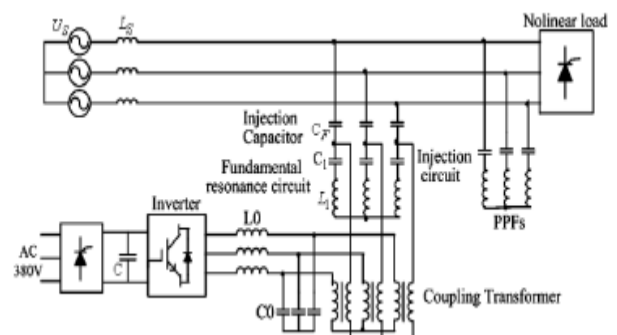

Fig.2 Topology of the novel HAPF

The APF, shunted to the fundamental resonance circuit, is directly connected in series with a matching transformer. Therefore, the novel HAPF (IHAPF) is formed. The PPF sustains the main grid voltage and compensates for the constant reactive power, while the fundamental resonance circuit only sustains the harmonic voltage, which greatly reduces the APF power and minimizes the voltage rating of the semiconductor switching device. So it is effective to be used in the 6-kV/10-kV medium-voltage grid.

In order to clarify the compensation principle of IHAPF, a single-phase equivalent circuit is shown in Fig., where APF is considered a controlled current source, I_{af} and the nonlinear load is considered to be a harmonic current source I_L . In Fig., U_S and L_S are the supply voltage and equivalent inductor of the grid. C_F , and C_1 , L_1 , C_P , and L_P are the injection capacitor, fundamental resonance capacitor, fundamental resonance inductor, and the PPF capacitor and inductor, respectively. Fig (b) is the equivalent circuit of the IHAPF only considering the harmonic component of the system. Z_{Sh} , Z_{Ph} , Z_{CF} , and Z_1 represent system impedance, PPF impedance, the impedance of the injection capacitor, and the fundamental resonance impedance. From Fig (b), we can see that

$$\begin{cases} I_{Sh} = I_{Fh} + I_{Lh} \\ U_{Sh} - I_{Sh}Z_{Sh} = I_{Ph}Z_{Ph} \\ I_{Fh} = I_{Ph} + I_{Gh} \\ I_1 = I_{Gh} + I_{af} \\ I_{Gh}Z_{Gh} + I_1Z_1 = I_{Ph}Z_{Ph} \end{cases}$$

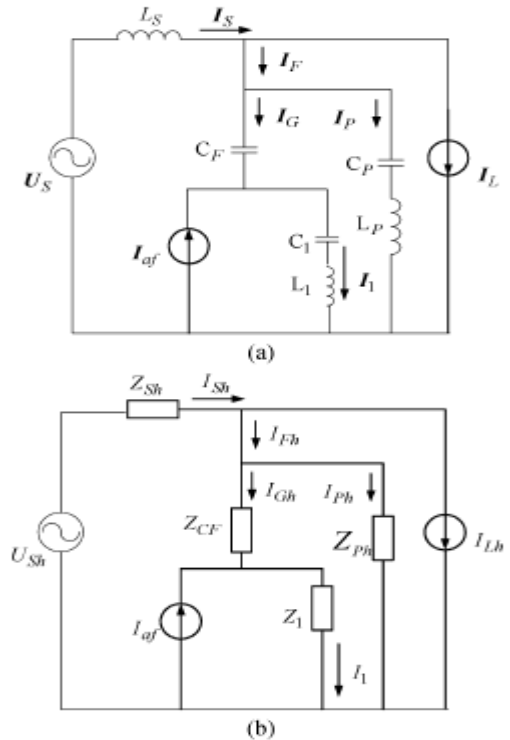

Fig.3 Single-phase equivalent circuit. (a) Single-phase equivalent circuit. (b) Single-phase equivalent circuit with the effect of a harmonic source

II. ADAPTIVE FUZZY DIVIDING FREQUENCY-CONTROL METHOD

The conventional linear feedback controller (PI controller, state feedback control, etc.) is utilized to improve the dynamic response and/or to increase the stability margin of the closed loop system. However, these controllers may present a poor steady-state error for the harmonic reference signal. An adaptive fuzzy dividing frequency control method is presented in Fig., which consists of two control units: 1) a generalized integrator control unit and 2) a fuzzy adjustor unit. The generalized integrator, which can ignore the influence of magnitude and phase, is used for dividing frequency integral control, while fuzzy

arithmetic is used to timely adjust the PI coefficients.

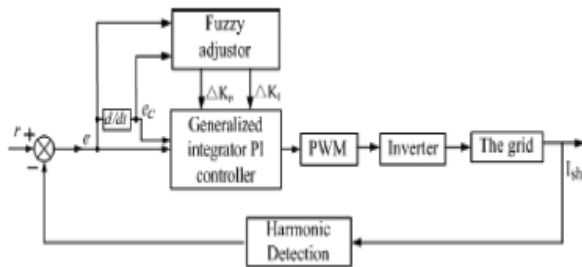

Fig.4 Configuration of the adaptive fuzzy dividing frequency controller

Since the purpose of the control scheme is to receive a minimum steady-state error, the harmonic reference signal r is set to zero. First, supply harmonic current is detected. Then, the expectation control signal of the inverter is revealed by the adaptive fuzzy dividing frequency controller. The stability of the system is achieved by a proportional controller, and the perfect dynamic state is received by the generalized integral controller. The fuzzy adjustor is set to adjust the parameters of proportional control and generalized integral control. Therefore, the proposed harmonic current tracking controller can decrease the tracking error of the harmonic compensation current, and have better dynamic response and robustness.

B. Fuzzy Adjustor

The fuzzy adjustor is used to adjust the parameters of proportional control gain K_P and integral control gain K_I , based on the error e and the change of error e_c

$$\begin{cases} K_P = K_P^* + \Delta K_P \\ K_I = K_I^* + \Delta K_I \end{cases}$$

Where K_P^* and K_I^* are reference values of the fuzzy-generalized integrator PI controller. In this

paper, K_P^* and K_I^* are calculated offline based on the Ziegler–Nichols method. In a fuzzy-logic controller, the control action is determined from the evaluation of a set of simple linguistic rules. The development of the rules requires a thorough understanding of the process to be controlled, but it does not require a mathematical model of the system. A block diagram fuzzy-logic adjustor is shown in Fig 5.

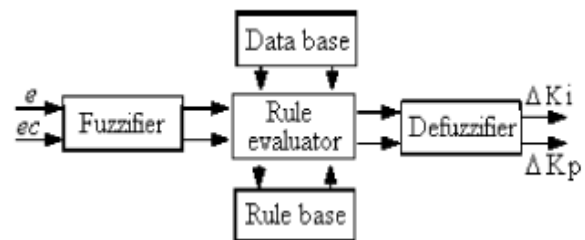

Fig.5 Block diagram of the fuzzy adjustor unit

In this way, system stability and a fast dynamic response with small overshoot can be achieved with proper handling of the fuzzy-logic adjustor. Fuzzification converts crisp data into fuzzy sets, making it comfortable with the fuzzy set representation of the state variable in the rule. In the fuzzification process, normalization by reforming a scale transformation is needed at first, which maps the physical values of the state variable into a normalized universe of discourse.

The error e and change of error e_c are used as numerical variables from the real system. To convert these numerical variables into linguistic variables, the following seven fuzzy levels or sets are chosen as : negative big (NB), negative medium (NM), negative small (NS), zero (ZE), and positive small (PS), positive medium (PM), and positive big (PB). To ensure the sensitivity and robustness of the controller, the membership function of the fuzzy sets for $e(k)$, $e_c(k)$, ΔK_P , and ΔK_I in this paper are acquired from the ranges

of e , e_c , ΔK_P , and ΔK_I , which are obtained from project and experience. And the membership functions are shown in Fig., respectively.

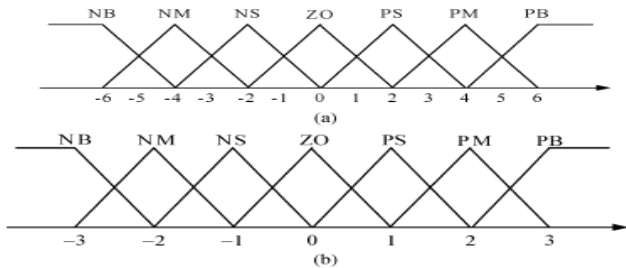

Fig.6 Membership functions of the fuzzy variable.
 (a) Membership function of $e(k)$ and $e_c(k)$ (b) Membership function of ΔK_P and ΔK_I .

The core of fuzzy control is the fuzzy control rule, which is obtained mainly from the intuitive feeling for and experience of the process. The fuzzy control rule design involves defining rules that relate the input variables to the output model properties. For designing the control rule base for tuning ΔK_P and ΔK_I , the following important factors have been taken into account.

- 1) For large values of $|e|$, a large ΔK_P is required, and for small values of $|e|$, a small ΔK_P is required.
- 2) For $e \cdot e_c > 0$, a large ΔK_P is required, and for $e \cdot e_c < 0$, a small ΔK_P is required.
- 3) For large values of $|e|$ and $|e_c|$, ΔK_I is set to zero, which can avoid control saturation.
- 4) For small values of $|e|$, ΔK_I is effective, and ΔK_I is larger when $|e|$ is smaller, which is better to decrease the steady-state error. So the tuning rules of ΔK_P and ΔK_I can be obtained as Tables.

TABLE: ADJUSTING RULE OF THE ΔK_P PARAMETER

| ΔK_P | | e_c | | | | | | |
|--------------|----|-------|----|----|----|----|----|----|
| | | NB | NM | NS | O | PS | PM | PB |
| e | NB | PB | PB | NB | PM | PS | PS | O |
| | NM | PB | PB | NM | PM | PS | O | O |
| | NS | PM | PM | NS | PS | O | NS | NM |
| | O | PM | PS | O | O | NS | NM | NM |
| | PS | PS | PS | O | NS | NS | NM | NM |
| | PM | O | O | NS | NM | NM | NM | NB |
| | PB | O | NS | NS | NM | NM | NB | NB |

TABLE: ADJUSTING RULE OF THE ΔK_I PARAMETER

| ΔK_I | | e_c | | | | | | |
|--------------|----|-------|----|----|----|----|----|----|
| | | NB | NM | NS | O | PS | PM | PB |
| e | NB | O | O | NB | NM | NM | O | O |
| | NM | O | O | NM | NM | NS | O | O |
| | NS | O | O | NS | NS | O | O | O |
| | O | O | O | NS | NM | PS | O | O |
| | PS | O | O | O | PS | PS | O | O |
| | PM | O | O | PS | PM | PM | O | O |
| | PB | O | O | NS | PM | PB | O | O |

The inference method employs the MAX-MIN method. The imprecise fuzzy control action generated from the inference must be transformed to a precise control action in real applications. The center of gravity method is used to defuzzify the fuzzy variable into physical domain

$$\begin{cases} K_P = K_P^* + \frac{\sum_{j=1}^n \mu_j(e, e_c) \Delta K_{Pj}}{\sum_{j=1}^n \mu_j(e, e_c)} \\ K_I = K_I^* + \frac{\sum_{j=1}^n \mu_j(e, e_c) \Delta K_{Ij}}{\sum_{j=1}^n \mu_j(e, e_c)} \end{cases}$$

III. Simulation and Application Results

A. Simulation Results

Simulation results of a 10-kV system have been carried out with software PSIM. The system parameters are listed in Table. The PPFs are turned at the 11th and 13th, respectively. The injection circuit is turned at the 6th. In this simulation, ideal harmonic current sources are applied. The dc-side voltage is 535 V. Simulation results with the conventional PI controller and the proposed current controller are shown in Figs. I_L , I_S , I_F , I_{apf} , and the error represent the load current, supply current,

current through the injection capacitor, current through APF, and error of compensation.

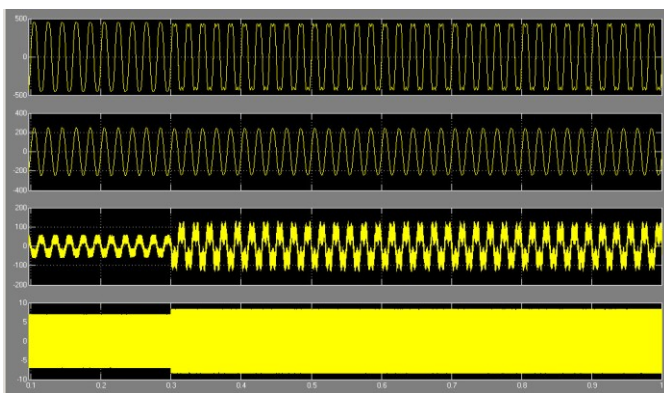
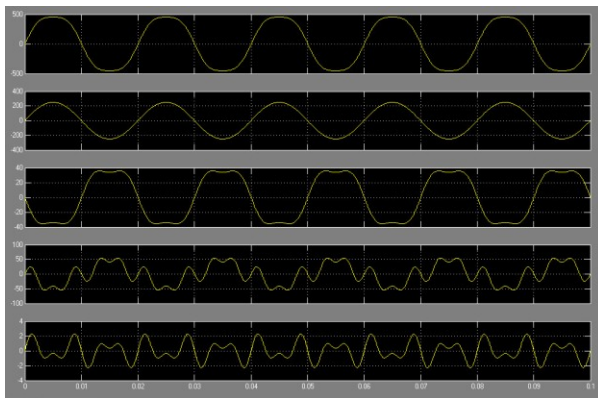
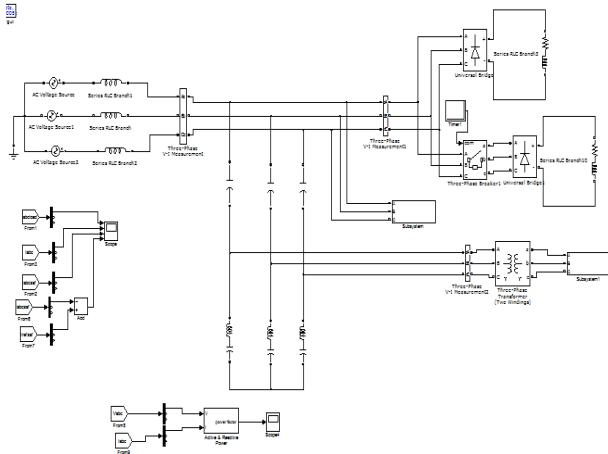

Fig. 7 Simulation results of steady-state compensation. (a) Simulation results with the conventional generalized integral controller. (b) Simulation results with the proposed fuzzy controller

Conclusion

A novel hybrid APF with injection circuit was proposed. Its principle and control methods were

discussed. The proposed adaptive fuzzy-dividing frequency control can decrease the tracking error and increase dynamic response and robustness. The control method is also useful and applicable to any other active filters. It is implemented in an IHAPF with a 100-kVA APF system in a copper mill in Northern China, and demonstrates good performance for harmonic elimination. Simulation and application results proved the feasibility and validity of the IHAPF and the proposed control method.

References

- [1] L. Gyugyi and E. C. Strycula, "Active ac power filters," in Proc. IEEE, Ind. Appl. Soc. Annu. Meeting, 1976, pp. 529–535.
- [2] N. Mohan, H. A. Peterson, W. F. Long, G. R. Dreifuerst, and J. J. Vithayathil, "Active filters for AC harmonic suppression," presented at the IEEE Power Eng. Soc. Winter Meeting, 1977.
- [3] F. Peng, H. Akagi, and A. Nabae, "A new approach to harmonic compensation in power system—a combined system of shunt passive and series active filters," IEEE Trans. Ind. Appl., vol. 26, no. 6, pp. 983–990, Nov. 1990.
- [4] C. Madtharad and S. Premrudeep reechacharn, "Active power filter for three-phase four-wire electric systems using neural networks," Elect. Power Syst. Res., vol. 60, no. 2, pp. 179–192,

BIBLIOGRAPHY

Madhuri Vukoti: pursuing M.Tech in Nimra college of engineering and technology, Jupudi, Ibrahimpatnam. His specialization in power systems. He graduated in Electrical and Electronics Engineering from DVR & Dr. HS MIC College of



Technology, Kanchikacherla. Mail ID
madhurivukoti@gmail.com

DR.Abdul Ahad : Mtech. P.hd (NITK) is an eminent PROFESSOR & HEAD OF EEE , nimra group of colleges. he received M.Tech and was conferred Doctorate from NITK SURATKAL. He is expertised in power electronics, power systems, special machines, Electrical machines& industrial applications. He has over a 15 years of teaching

experience .He trains various students for various competitive exams like IES ,IAS, GATE , AP GENCO,AP TRANSCO, DISCOMS and no of national competitive exams. He is the chair person of several national and technical symposiums. He published more than 20 international journals and attended several international conferences. His prime interest is in research .to his credit he guided scores of UG AND PG students in their projects and right now he is guiding two P,hd scholars.