



Positive Sequence Admittance and Negative Sequence Conductance to Mitigate Voltage Fluctuations in DG systems by using FUZZY controller with D-STATCOM

Mahaboobunnisa¹ & G.PoornachandraRao²

¹M. Tech Scholar, Dept of EEE, VBIT, Hyderabad. mahaboobunnisa284@email.com

²Asst. Professor, Dept. of EEE, VBIT, Hyderabad. g.poornachandrarao@gmail.com

ABSTRACT:

In present days, most of the distributed generations depends on renewable energy sources (such as solar or wind) due to its vast advantages. To reduce transmission & distribution costs, network congestion and losses distribution generations (DGs) are connected to micro grids for the distribution of power to the consumers. Increasing the connections of DGs causes voltage fluctuations in the distribution network due to variable output power of DGs with renewable energy sources. Voltage fluctuations are one of the power quality problems and causes severe problems in the power system network such as over loading of transformer, reducing the life time of equipment, sensitive equipment malfunctioning, system losses. This paper presents compensation of voltage fluctuations in DGs using Distributed Static synchronous Compensator (D-STATCOM) with fuzzy logic controller. Tuning control is designed to alleviate the variations of negative and positive sequence voltages whenever the disturbance occurs in the network. The results are verified by simulating the developed method in mat lab environment.

Key Words: Fuzzy Logic Controller; D-STATCOM; Distributed Generation System; Pulse Width Modulation; etc

I.INTRODUCTION:

Nonconventional energy is consistent and reliable will doubtless be lowest once technology and infrastructure develop. A renewable source includes wind, solar, hydrothermal and geothermal, tidal energy, plus biofuels that are full pledged and harvested without fossil fuels.

Conventional energy, such as petroleum and coal, require rich explorations and doubtless dangerous drilling and mining, and they will become more costly as supplies decrease and demand grownup.

Nonconventional energy produces only minute levels of carbon emissions and as a result helps combat climate change with the usage of fossils. The aggregation of Renewable Energy sources (RES) at the distribution level is termed as Distributed Generation (DG).

Micro grid [1]-[2] may be defined as a collection of distributed generation (DG) units usually connected through power electronic based devices (voltage source inverter & current source inverter) to the utility grid. DG units can be built with renewable energy sources such as solar energy, fuel cells, hydroelectric power, and wind energy. Small grid can function either linked to the grid or isolated from the grid.

Great penetration of RES reason for issues instability, flickering, voltage regulation and power quality of the system.

Different types of problems in power quality. These problems are power factor, harmonic distortion, reactive power compensation and voltage fluctuations.

Commonly, single-phase loads distribution, transmission lines impedances, different loading types would lead to voltage fluctuations in power system. This problem is much severe in case of micro grids because of power flow in reverse direction with the Distributed Generations in either single phase or three phase connection [3]. Voltage variations in the power system causes system losses, transformer overloading, capacity reduction, motor overheating and may results in Sensitive equipment malfunction, protected devices nuisance tripping and output limitation of DGs. Hence, voltage regulation is compulsory needed in grid connected operation to allow more DGs to join.

Various types of FACT devices like UPFC, SVC, STATCOM, IPC, DVR, TCSC, TCPST and D-STATCOM can be used to solve these types of complications in the power system network.

All the FACT devices have its own application. But in case of distribution system D-STATCOM is suitable device to compensate voltage fluctuations, reactive power and harmonics i.e. for all power quality problems DG systems.

D-STATCOM is used in distribution system for reactive power compensation and to control voltage fluctuations as well as to decrease harmonics. D-STATCOM is connected in shunt with transmission lines. In case if we are transmitting sum of power through transmission lines and at receiver end we are getting it with somenoise or any other disturbance that means losses are present in the network. Disturbance may be voltage sag, reactive power and harmonics.

Fuzzy logic controller [4]-[6] is extensively used in controlling disturbances in power systems. The alternate controller known as PI controller is not worthful for many reasons. PI controller includes its incapability to withstand rapid changes in error signal and it is not dynamic in identifying the present error signal. This paper presents the usage of fuzzy logic controller in order to improve the performance of D-STATCOM for Dc-bus voltage control for compensating negative sequence and positive sequence voltages.

Voltage variations are restricted to $\pm 5\%$ as the non conventional energy sources are operated in parallel to systems which are having low voltages as per IEEE Std 1547.2-2008 [7]. A voltage fluctuation indicated by %VUF (Voltage Unbalance Factor) and is kept below 2.0% to 3.0% which is acceptable for both manufacturers and utility, where %VUF is defined as the ratio of the negative-sequence voltage to the positive sequence voltage [8].

2. D-STATCOM OPERATION:

D-STATCOM is being designed with a conventional 3- \emptyset voltage source inverter and it is coupled to the distribution systems through a boost up transformer and its diagram is as shown in the Fig-1.

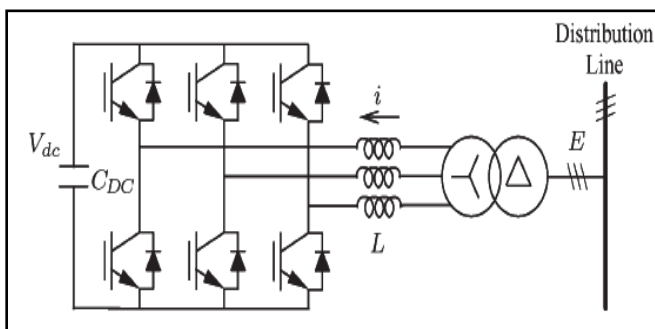

Fig -1: power circuit of D-STATCOM

The implemented D-STATCOM operates as fundamental negative-sequence conductance and fundamental positive-sequence admittance as given in eq.1

$$i^* = Y_p^* \cdot E_f^{+} + G_n^* \cdot E_f^{-} \dots\dots\dots (1)$$

Where i^* indicates the reference current, E_f^{+} indicates the quadrature fundamental positive-sequence voltage, and E_f^{-} is the fundamental negative-sequence voltage.

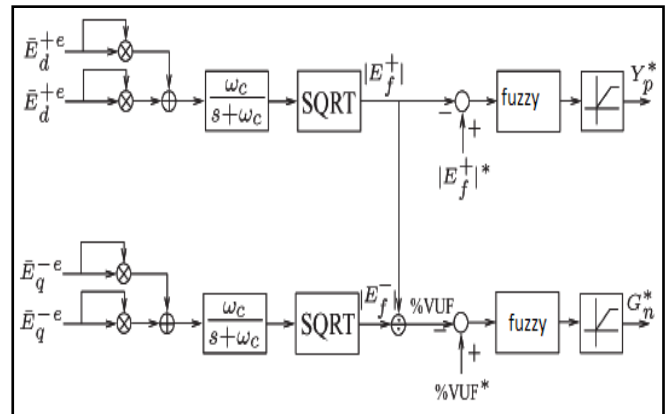

Fig -2: reference current generation.

A. REFERENCE-CURRENT GENERATION:

Synchronous Reference Frame (SRF) theory is used to realize the control circuit as shown in Fig. 2. To filter out ripple components, a Low Pass Filter is used to generate the positive-sequence voltage E_{qd}^{+e} along with Low Pass Filter a band rejected filter which is tuned at the second-order harmonic frequency is required in order to find out the negative-sequence voltage E_{qd}^{-e} . With the application of reverse transformation, and the negative sequence voltage $|E_f^{-}|$ and the quadrature fundamental positive-sequence voltage $|E_f^{+}|$ in the three-phase system are available, where $|E_f^{+}|$ is lagging behind the fundamental positive-sequence voltage with an angle of 90 degrees. The negative-sequence current command i_f^{*-} and the positive-sequence current command i_f^{*+} are equal to product of Y_p^* and $|E_f^{+}|$, product of G_n^* and $|E_f^{-}|$ respectively. Therefore the reference current i^* is obtained as shown in the eq.1. For the proper operation of the D-STATCOM fuzzy controller is utilized to generate fundamental current which is in phase with the positive-sequence voltage in order to maintain the voltage of the DC bus V_{dc} at the reference value of voltage V_{dc}^* .

B.FUZZY LOGIC CONTROLLER:

Fuzzy logic is an intelligent system hence it has numerous applications in different fields such as control engineering, power engineering, medical, control of subway systems, pattern etc. Fuzzy logic controller contains fuzzifier, inference mechanism, defuzzifier to perform the operation. It incorporates simple IF-THEN rules to solve many control system problems rather than attempting a problem in mathematical model. We can get the fuzzy logic controller and fuzzy logic controller with rule viewer blocks in the fuzzy logic tool box. It also allows us to utilize how rules can be built at the time of simulation.

C. FUZZY LOGIC TOOLBOX WORKING:

Fuzzy logic tool box provides design of fuzzy logic systems using command line functionality and graphical user interface (GUI) tools. It can also be used to build adaptive neuro fuzzy inference systems and fuzzy expert systems. To observe, build and edit fuzzy inference systems in the fuzzy logic tool box five GUI tools are present. They are membership function editor, surface viewer, FIS editor, rule viewer, rule editor. There are two types of inference methods. They are Mamdani & Sugeno fuzzy inference method. Mamdani is the most common methodology used in all applications.

D. CONTROL OF CURRENT:

Current command is based on the reference current i^* , the current measured i , and the voltage measured is E from Fig-1. The current regulator shown in below

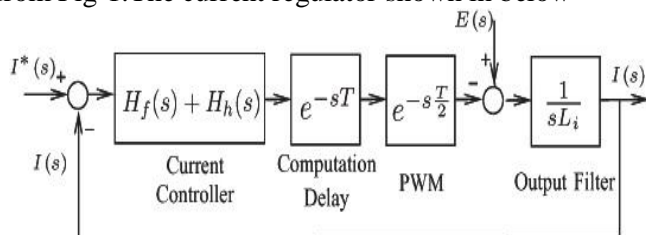

Fig-3: Current control loop diagram

Fig-3 produces for space vector pulse width modulation (PWM) control voltage command v^* of the inverter. The defined transfer functions $H_f(s)$ and $H_h(s)$ are given as follows

$$H_f(s) = k_p + \frac{2K_{i,f}\xi w_f s}{s^2 + 2\xi w_h s + w_f^2}$$

$$H_h(s) = \sum_h \frac{2K_{i,h}\xi w_h s}{s^2 + 2\xi w_h s + w_h^2}$$

Where K_p means proportional gain, the fundamental frequency and its integral gain is W_f and $K_{i,f}$ respectively and the harmonic frequency and its integral gain represented as W_h and $K_{i,h}$ respectively. The damping ratio ξ is used to tune the current regulation to establish a peak of narrow gain intense at the fundamental frequency for tracking of the fundamental current and it will also introduce different narrow gain peaks to diminish current distortion near harmonic frequencies. For the control of parameters Y_p^* and G_n^* Fuzzy logic controller has to be designed.

$|E_f^+|$ and $|E_f^-|$ are approximately calculated by using SQRT and Low Pass Filter operation, where Low Pass Filters are considered at cutoff frequency $w_c = 10$ Hz in order to sort out the ripple components. After that, a Fuzzy controller is designed in order to produce Y_p in order to balance $|E_f^+|$ at prescribed value $|E_f^+|^*$. Therefore, Voltages can be maintained at its permissible level with control of G_n^* and imbalanced voltages are suppressed. Here, %VUF (percentage of voltage imbalance factor) is used to indicate the level of imbalanced voltage and it can be defined as the ratio of the negative-sequence voltage to the positive-sequence voltage.

$$|E_f^+| = \sqrt{\frac{\int_t^{t+T} (E_q^{+e}(t)^2 + E_d^{+e}(t)^2) dt}{T}}$$

$$|E_f^-| = \sqrt{\frac{\int_t^{t+T} (E_q^{-e}(t)^2 + E_d^{-e}(t)^2) dt}{T}}$$

$$\% VUF = \left| \frac{E_f^-}{E_f^+} \right| * 100$$

3. SIMULATION RESULTS AND DISCUSSIONS:

A Power system network rated at 23 KV and 100 MW is designed which is used to illustrate voltage fluctuations and to check the performance of the proposed D-STATCOM. Basic Simulink model for 5 bus system for D-STATCOM operation is shown in Fig-4.

As the voltage of grid at the end of a line is very much sensitive to the addition of both reactive and real powers depending on the load flow analysis, so the D-STATCOM is installed at the end of the line. Voltage fluctuations are measured in terms of positive sequence voltage $|E_f^+|$ and voltage unbalance factor (%VUF).

A. STEADY-STATE PERFORMANCE:

Without D-STATCOM voltages are increased significantly as shown in Fig-5 (a). Table-1 provides

without D-STATCOM voltage fluctuations are worst and increases beyond the nominal values ($|E_f^+| = 1, \%VUF=1$).

When D-STATCOM on with $Y_p^*=0.37$ but $G_n^*=0, |E_f^+|$ at every bus will maintains nominal value. As there is no compensation of negative sequence voltage %VUF at every bus will be same as in the case of without D-STATCOM shown in Fig-5©&TABLE-2. In this case

D-STATCOM with rms currents $i_a = i_b = i_c = 0.37pu$. When D-STATCOM on with $G_n^*=9.6pu$ & $Y_p^*=0.37pu$, it will compensate both $|E_f^+|$ and %VUF to their nominal values as shown in Fig-5(e)&TABLE-3. In this case rms currents of D-STATCOM are $i_a=0.52pu, i_b=0.25pu, i_c=0.35pu$.

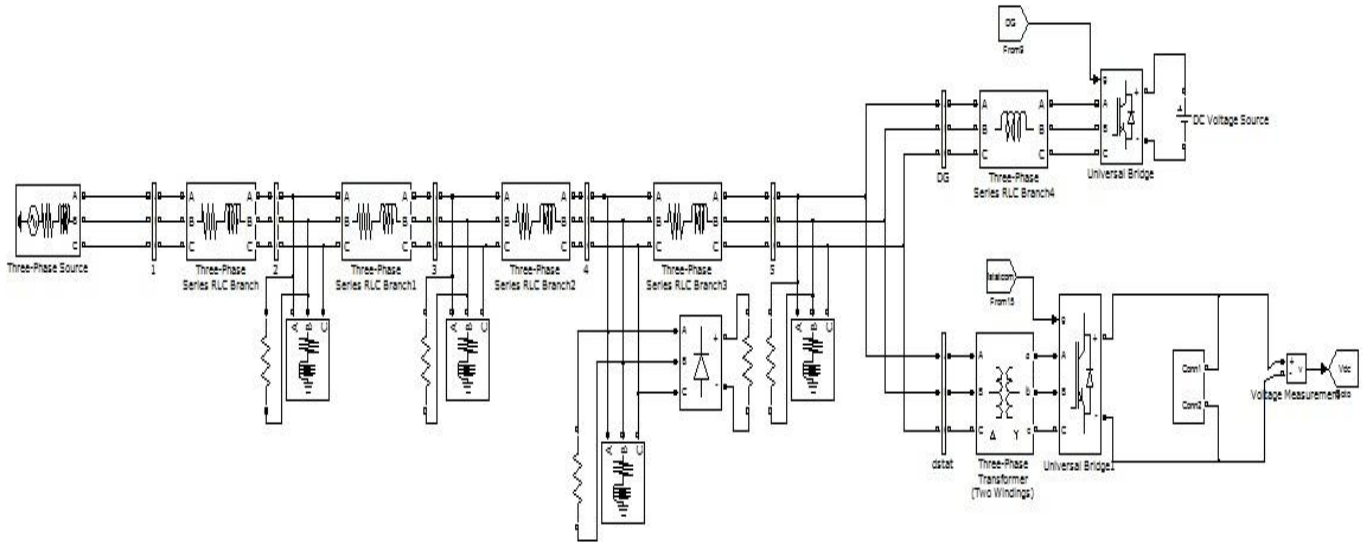

Fig – 4: simulink model for 5bus system

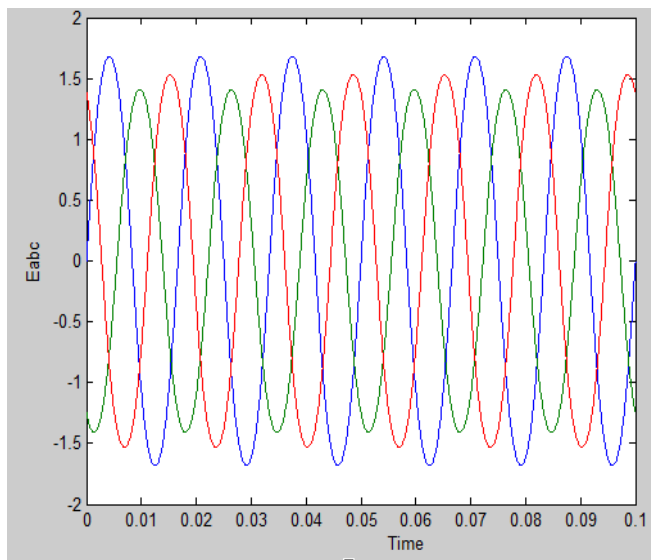

Fig – 5(a): Voltage E_{abc} without D-STATCOM

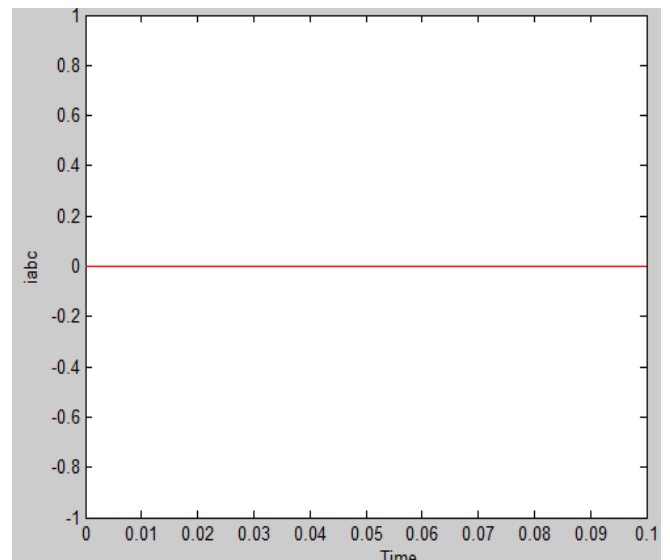

Fig – 5 (b): Current i_{abc} without D-STATCOM

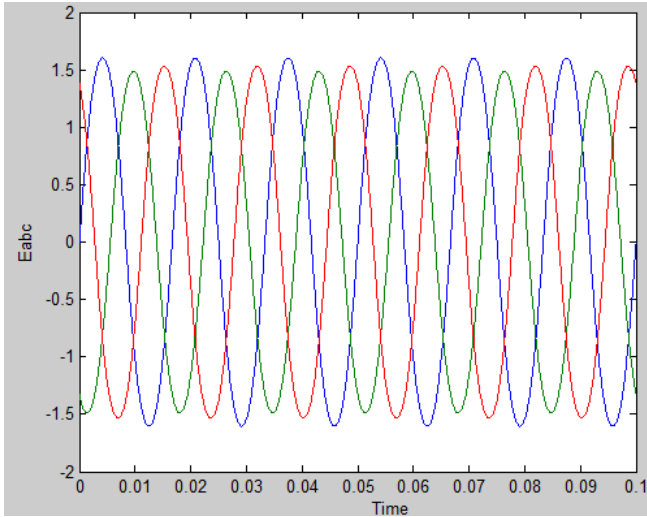

Fig – 5(c): Voltage E_{abc} with D-STATCOM on but $G_n=0$

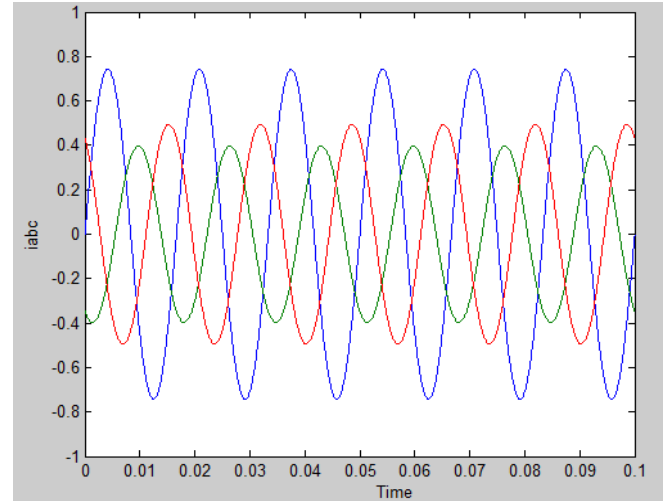

Fig – 5(f): Current i_{abc} with D-STATCOM on

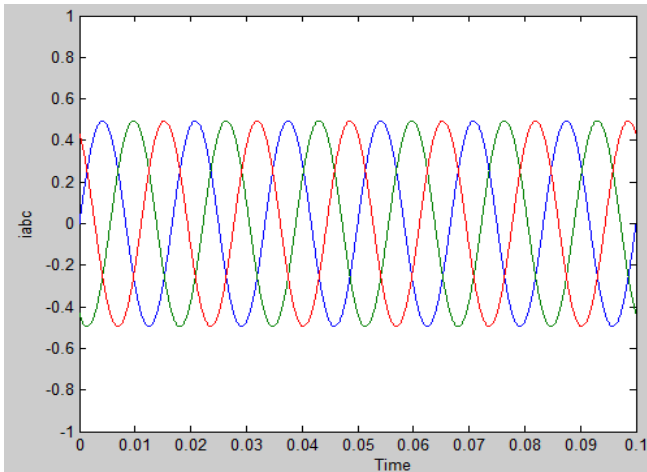

Fig – 5 (d): Current i_{abc} with D-STATCOM on but $G_n=0$

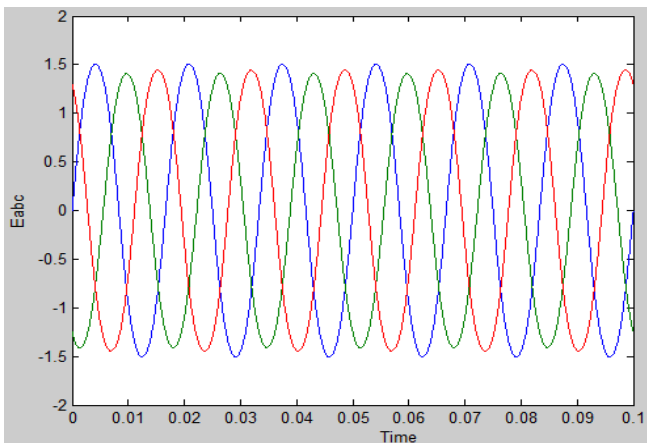

Fig – 5 (e): Voltage E_{abc} with D-STATCOM on

TABLE-1: BUS VOLTAGES WHEN D-STATCOM OFF

	Bus2	Bus3	Bus4	Bus5
$ E_f^+ $	1	1.02	1.04	1.06
%VUF	1.79	3.753	4.792	5.254

TABLE-2: BUS VOLTAGES WHEN D-STATCOM COMPENSATE ONLY POSITIVE SEQUENCE VOLTAGE

	Bus2	Bus3	Bus4	Bus5
$ E_f^+ $	1	1	1	1
%VUF	1.79	3.753	4.792	5.254

TABLE-3: BUS VOLTAGES WHEN D-STATCOM COMPENSATES BOTH NEGATIVE AND POSITIVE SEQUENCE VOLTAGE

	Bus2	Bus3	Bus4	Bus5
$ E_f^+ $	1	1	1	1
%VUF	1.703	1.905	2.021	2.021

Fig.-5: Simulation results (a) E_{abc} during D-STATCOM off (b) i_{abc} during D- STATCOM off (c) E_{abc} during D- STATCOM on but $G_n^*=0$ (d) i_{abc} during D- STATCOM on but $G_n^*=0$ (e) E_{abc} during D-STATCOM on (f) i_{abc} during D- STATCOM on.

B. TRANSIENT OPERATION:

At $t=4$ and 6 s, three phase loads are off at buses 3 & 4 hence E_f^+ is increased slightly as shown in Fig-6(a). To maintain E_f^+ at nominal value Y_p, Y_p is increased beyond 0.37 pu as shown in Fig-6(c).

At $t=7s$, single phase load is off at bus4 hence %VUF reduces as shown in Fig-6(b). To maintain %VUF at nominal value G_n^* , G_n decreases from 9.6pu as shown in Fig-6(d).

At $t=8s$, when DG output decreases from 0.9pu to 0.45pu at bus5, $|E_f^+|$ & %VUF are slightly increased and decreased respectively. To maintain voltages at their nominal values Y_p further decreases and G_n is slightly increased as shown in Fig-6(c) & Fig-6(d).

At $t=9s$, DG output further decreases from 0.45pu to 0pu interestingly Y_p^* is negative to maintain the fluctuated voltages to nominal values.

Fuzzy logic controller tunes Y_p^* and G_n^* accordingly with the variations in the power system network, to maintain the voltages at allowable levels.

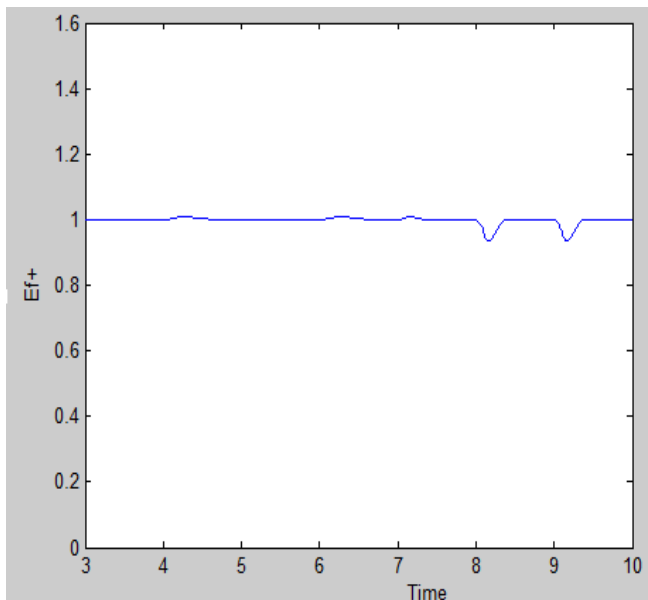

Fig – 6(a): Positive sequence voltage $|E_f^+|$ during transient period

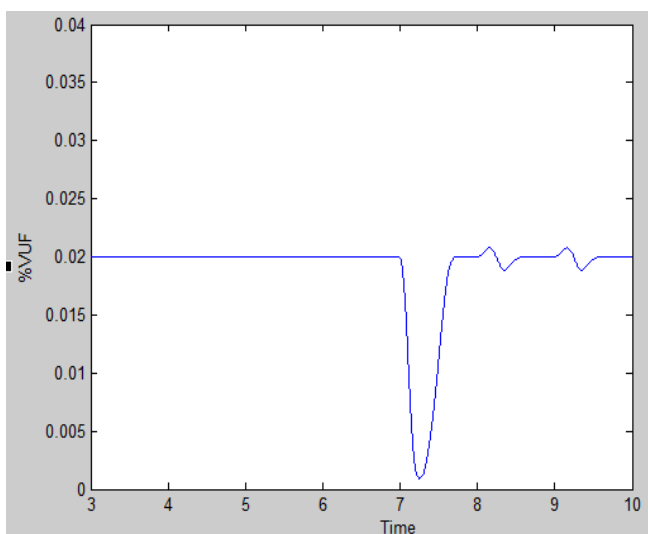

Fig – 6(b): Voltage Unbalance Factor (%VUF) during transient period

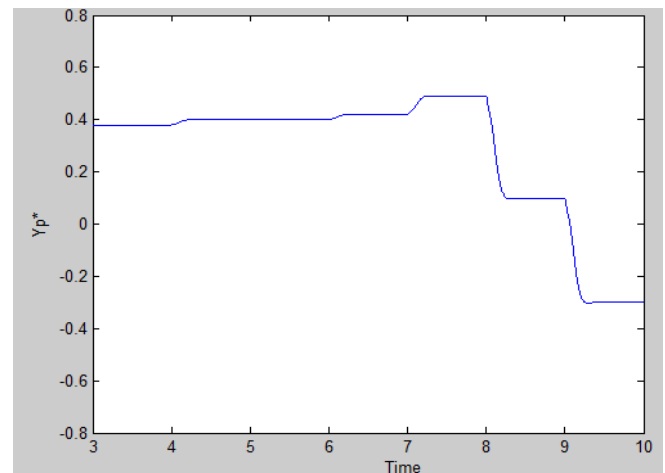

Fig – 6(c): Positive sequence admittance Y_p^* during transient period

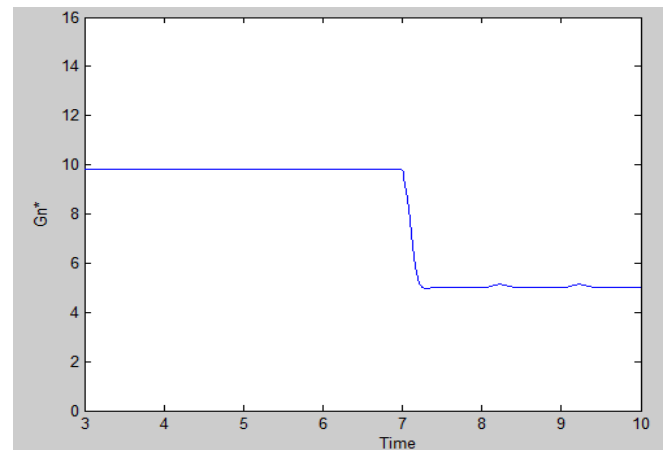

Fig – 6(d): Negative sequence conductance G_n^* during transient period

4. CONCLUSION:

In this paper, fuzzy logic controller along with negative sequence conductance and positive sequence admittance was used to control the D-STATCOM which reduces voltage fluctuations in Distributed Generation systems. In order to maintain both negative and positive sequence voltages at tolerable level a tuning control is implemented to dynamically vary conductance and admittance commands. D-STATCOM operation and its voltage regulation during different situations have been discussed. By adjusting conductance and admittance the operation of D-STATCOM is controlled, the compromise between the required improvement on power quality and the D-STATCOM rating can be accomplished.

The D-STATCOM in the proposed method can be implemented at the same location in order to mitigate voltage fluctuations in Distributed Generation systems



using fuzzy logic controller along with negative sequence conductance and positive sequence admittance, hence, more Distributed generations can be allowed online. At last, the D-STATCOM cooperative control has been discussed. The D-STATCOM along SVC and OLTC to control the voltage of the grid by employing a low frequency communication.

5. REFERENCES

[1] R. Lasseter, "Microgrids," in Proc. IEEE Power Eng. Soc. Winter Meeting, 2002, pp. 305–308.

[2] F. Katiraei, R. Iravani, N. Hatziargyriou, and A. Dimeas, "Micro grids management," IEEE Power Energy Mag., vol. 6, no. 3, pp. 54–65, May/Jun. 2008.

[3] C. L. Masters, "Voltage rise: The big issue when connecting embedded generation to long 11 kV over headlines," Inst. Elect. Eng. Power Eng. J. vol. 16, no. 1, pp. 5–12, Feb. 2002.

[4] A. Ajami and H. S. Hosseini, "Application of Fuzzy Controller for Transient Stability Enhancement of AC Transmission System by STATCOM," International Joint Conference SICE-ICASE, pp. 6059–6063, 2006.

[5] Recently, intelligent controllers like Fuzzy Logic Controllers (FLC) and Artificial Neural Network (ANN) as alternative linear and nonlinear control techniques have been used in control of D-STATCOM.

[6] A. LUO, C. Tang, Z. K. Shuai, J. Tang, X. Y. Xu and D. Chen, "Fuzzy-PI- Based Direct-Output-Voltage control strategy for the STATCOM used in utility distribution systems," IEEE Trans. Ind. Electron., vol. 56, no. 7, July 2009.

[7] IEEE Standard for Interconnecting Distributed Resources with Electric Power Systems, IEEE Std. 1547.2-2008,

[8] A. V. Jouanne and B. Banerjee, "Assessment of voltage unbalance," IEEE Trans. Power Del., vol. 16, no. 4, pp. 782–790, Oct. 2001.