

# Back-Propagation Control Algorithm for Power Quality Improvement Using UPFC

Rachapudi Vinod Kumar<sup>1</sup>, Dr. P. Sujatha<sup>2</sup>, Dr. R.Kiranmayi<sup>3</sup>

<sup>1</sup>PG Student, Dept. of EEE, JNTUA, Ananthapuramu, Andhra Pradesh, India

<sup>2</sup>M.Tech, PHD, Professor, Dept. of EEE, JNTUA, Ananthapuramu, Andhra Pradesh, India

<sup>3</sup>M.Tech, PHD, Associate Professor, , Dept. of EEE, JNTUA, Ananthapuramu, Andhra Pradesh, India

**Abstract :-**This project exhibits the execution of a three stage distribution static compensator (DSTATCOM) by utilizing a back propagation (BP) control algorithm for its capacities, for example, load balancing and reactive power compensation zero voltage regulation under nonlinear loads .For the extraction of the crucial weight estimation of dynamic here we are utilizing BP-based control algorithm. And BP based control algorithm is also used for the estimation of receptive power parts of burden streams which are required for the estimation of reference source streams.Control of power quality devices by neural networks is a latest research area in filed of power engineering.Extraction of harmonic components decides the performance of compensating devices.Here we are using DSTATCOM and UPFC as compensating devices.A model of DSTATCOM is created utilizing a computerized *signal processor*, and its execution is concentrated on under different working conditions. The execution of DSTATCOM is observed to be acceptable with the proposed control algorithm for different sorts of burdens. A BP based control algorithm is used for extraction of fundamental weighted value of active and reactive power components of load currents.Back propagation algorithm which is trained the sample can detect the signal of power quality problem in real-time.Continuity,differentiability,non-decreasing momotomy are the main characteristics of this algorithm. The operation of UPFC is similar to the DSTATCOM but the only advantage is that it doesnot make the system shut down under worse conditions.UPFC is a novel power transmission controller.To control the power flow and to optimize the system stability in the transmission line UPFC is mostly preferred.A control system which enables the UPFC to follow changes in reference values like AC voltage,DC voltage and angle order of the series voltage source converter is simulated.The UPFC is a combination of a

static synchronous compensator (STATCOM) and a static synchronous series compensator (SSSC) coupled via a common DC voltage link. The main advantage of the UPFC is to control the active and reactive power flows in the transmission line steady.state problems.UPFC is one of the most important FACT device.The results are also verified for UPFC. The proposed system is verified by the results of MATLAB/Simulink.

## I.INTRODUCTION

The major problem today the distribution system facing is power quality.The quality of power that is given to the end users is not upto the mark.Because of this there is a failure in the devices.Inorder to overcome this problem that means to improve the quality of the power we are implementing certain devices in the transmission system.Power converter based custom power devices (CPDs) are useful for reduction of power quality problems such as power factor correction, harmonics compensation,reduction in transients,voltage sag/swell compensation, resonance due to distortion, voltage flicker reduction within specified time and range. These CPDs include DSTATCOM, DVR and UPQC in different Configurations. Many non model and training based alternative control algorithms are reported in the literature with application of soft computing technique such as neural network, fuzzy logic and adaptive neuro-fuzzy etc.A VSC based DSTATCOM has been introduced for better power quality improvement and thereby improving power factor correction and maintaining rated PCC voltage.For power quality improvement as power factor correction and to maintain rated PCC voltage a

voltage source converter(VSC) based DSTATCOM has been preferred in the distribution systems.. A three phase DSTATCOM has been implemented for compensation of nonlinear loads using BPT control algorithm to verify its worthyness.For the extraction of reference source currents to generate the switching pulses for IGBTs of VSC of DSTATCOM has been made by the proposed BPT algorithm.. Various functions of DSTATCOM are as follows, harmonic elimination and load.MATLAB with SIMULINK and Sim Power System (SPS) toolboxes are used for the development of simulation model of a DSTATCOM and its control algorithm.By examining the simulation results the performance of the DSTATCOM with BPT algorithm has been found satisfactory for this application because extracted reference source currents performed well in tracing the sensed source currents during steady state as well as under dynamic conditions. The DC bus voltage of the DSTATCOM has also been regulated to rated value without any overshoot or undershoots during load variation that is under varying loads.

This paper presents minimum conditions for the losses in distribution systems and experimentally achieving them by using UPFC.The main advantage of UPFC here is that we can independently control the active and reactive powers when needed. Enhanced power quality improvement is the essential necessity of any electrical equipment. Almost all power quality problems originate from disturbances in the distribution networks.The most common problem that is reported in low and medium level distribution sytem is harmonic resonance.So we have to overcome this by using certain filters.It has numerous points of interest, for example, most extreme use of electrical types of gear, improved stacking ability, zero voltage regulation,power factor correction and so on. Wellsprings of poor power quality can be separated in view of purchaser burdens also, subsystem of a conveyance framework. These purchaser burdens can be named straight, nonlinear, or blended sort of loads.So to overcome the problems that are neglected by DSTATCOM we are using UPFC.UPFC consists of a series and a shunt converter which is connected back –to-back through

a common DC link.In order to overcome these limitations Back Propagation (BP) has been implemented.An improved Back Propagation control algorithm and linear sinusoidal tracer control algorithm is implemented on a DSTATCOM for the extraction of load currents and fundamental components in three phase consumer loads that is on the consumer side.Internal parameters of this algorithm have clear physical understanding and easy adjustable to optimal value that is to our required value.It is obtained by continuously training the algorithm,which shows the simplicity of this algorithm.Frequency-and time-domain characteristics of the ILST are not affected due to external environment changes and this is another advantage of using artificial neural networks on the distribution system. Detection accuracy and speed of the dynamic response can be tuned after adjusting the algorithm's internal parameters. In this algorithm, extracted reference source currents from the trained network exactly follows the actual source currents that are in the non linear distribution system during steady-state as well as dynamic conditions. For this reason, three-phase source currents have smooth variation during load perturbations which is a preferrable condition.

This control algorithm is implemented on a DSTATCOM which is on the distribution system lines for compensation of linear and nonlinear loads. The advantages of these systems are as follows, (i)This method will not be affected by the initial gain settings, changes of system conditions, and the limits of human experience and judgment, Self-tuning process,(ii)Better response for dynamic system, Voltage Regulation, power factor correction is achieved.(iii)Power quality issues are gaining significant attention due to the increase in the number of sensitive loads on the end user side. Many of these loads use equipment that are sensitive to distortions or dips in supply voltages.So it may cause a failure in the system or complete shut down of the grid which is not acceptable.Regulations is applied in many places on the distribution system which limit the distortion,transients and unbalanced conditions that a customer can inject into a distribution system.

These regulations may require the installation of compensators (filters) on customer premises. It is also expected that a utility will supply a low distortion balanced voltage to its customers, especially those with sensitive loads because increase in distortions leads to burning of the systems on customer side. A distribution static compensator (DSTATCOM) is a voltage source inverter (VSI)-based power electronic device. Usually, this device is supported by short-term energy stored in a DC capacitor. Because we know that a capacitor is an energy storing device. So it is connected back to back in the system. When a DSTATCOM is associated with a particular load, it can inject compensating current they are also called as injection currents. Because we are injecting these currents in the place where the system is unbalanced. So that the total demand meets the specifications for utility connection. The shunt converter is also connected in parallel with the transmission line by transformer which allows to control the UPFC's bus voltage/shunt reactive power and the DC capacitor voltage. Apart from this, it can also clean up the voltage of a utility bus from any unbalance, overshoots, transients and harmonic distortion. The mitigation of power quality problems can be achieved in two ways. It can be done from either the customer side or utility side. First approach used is load conditioning and other is line conditioning.

## II. SYSTEM CONFIGURATION AND CONTROL ALGORITHM

One of the major considerations while using DSTATCOM for load compensation is the generation of the reference compensator currents that are taken from the load line. There are several training methods that have been developed for the use of the compensator when it tracks these reference currents, and thereby injecting these three-phase currents in the AC system to cancel out the disturbances caused by the load in the distribution

system[2-5]. The execution of DSTATCOM depends upon the exactness of music streams, tuned esteem of interfacing conductors ( $L_f$ ) are joined at air conditioning yield of the VSC. For all the methods that are present for suppression of harmonics there is a common belief that the voltage at the point of common coupling is tightly regulated and cannot be influenced by the currents injected by the shunt device which is connected externally on the distribution system. The DSTATCOM employs an inverter to convert the DC link voltage of adjustable magnitude and phase i.e., to an alternating one. It is basically connected near to the load because we can inject dc components on to the load. So here we are employing inverter which converts DC to AC and vice versa. The schematic diagram of a VSC based DSTATCOM is shown on the below fig which is connected in shunt to the distribution network along with the controller.

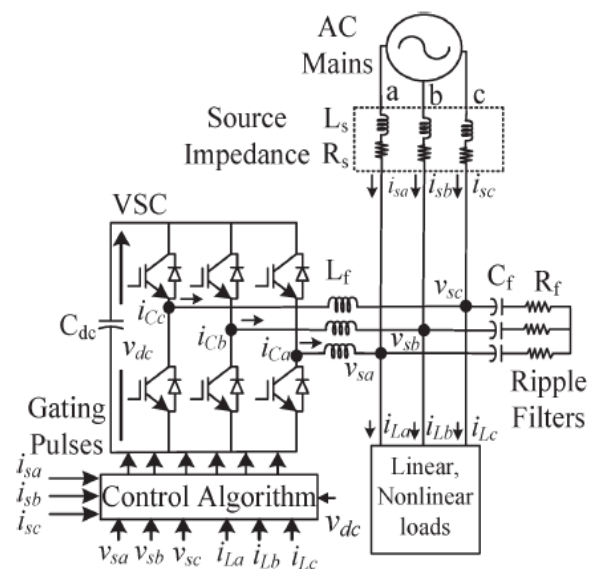

Fig. 1. Schematic diagram of VSC-based DSTATCOM.

There are two different modes in which a DSTATCOM can operate. They are (1) voltage mode and (2) current mode. The basic operation that is carried out in a voltage control mode is the DSTATCOM is connected at a utility bus to maintain

a balanced voltage at that bus, irrespective of unbalance or distortion on either side of the bus. In this mode, responsibility of the utility is the operation and maintenance of the DSTATCOM effectively. In a voltage control mode, it can make the voltage of the bus to which it is connected a balanced sinusoid, irrespective of the unbalance and distortion in voltage in the supply side or line current. Alternatively, in the current control mode, the DSTATCOM compensates for any unbalance or distortion in the load. Ideally, it should draw a balanced load current from the system, irrespective of any unbalance or harmonics in either the source or load side. Similarly when operated in a current control mode, it can force the source side currents to become balanced sinusoids. It is also assumed that the DSTATCOM is placed at a utility bus on customer. The phase of the output voltage of the thyristor based inverter,  $V_i$ , is controlled in the same way as the distribution system voltage  $V_s$ .

A DSTATCOM is capable of compensating either bus voltage or line current.

Three load buses. It is assumed that consumers are supplied from these buses. A DSTATCOM can be connected in any of these buses, depending on whether it belongs to the utility or a particular customer. For example, if the voltage at bus 3 is distorted, it affects customers both at buses 3 and 4. The utility may then install a DSTATCOM at this bus to clean up its voltage. On the other hand, suppose that the consumer at bus 4 has loads that draw unbalanced and distorted current from the supply. In order to avoid a penalty, one option for the consumer is to install a DSTATCOM on its premises, so that the current drawn from bus 4 is a balanced. VSCs using PWM controllers are the mainstay of modern power electronics controllers, such as STATCOM, DVR and HVDC-VSC stations. One of the many advantages of VSCs using PWM control is that they can produce quasi-sinusoidal voltage waveforms, having almost any desired phase relationship with an existing AC system waveform, thus dictating the direction and magnitude of the active and reactive power exchanged with the AC system. In practice, the high harmonic frequencies generated by the VSC could be filtered out by high-frequency harmonic

filter [101], but in real time the operation of such filters will not be perfect or they may not even be operating. Moreover, harmonic interactions between the VSC and the electric network will always take place. This interaction may produce harmonic resonances which can only be predicted with realistic models of the VSC and the electric network. Comprehensive models for power converters have been reported in the open literature. In power systems harmonic studies, switching functions have found widespread acceptance in the modeling of converters based on thyristor, where the commutation period of the thyristors has been included in the switching functions. As an extension, switching functions have also been used in the modeling of converters based on GTOs or IGBTs, showing even greater adequacy than in the former application.

### III. CONTROL ALGORITHM

The back propagation algorithm looks for the minimum of the error function in weight space using the method of gradient descent. This numerical method was used by different contexts. The combination of weights which minimizes the error function is considered to be a solution of the learning problem. Since this method requires computation of the gradient of the error function at each iteration step, we must guarantee the continuity and differentiability of the error function. Obviously we have to use a kind of activation function other than the step function used in perceptrons because the composite function produced by interconnected perceptrons is discontinuous, and therefore the error function too. Since this method requires computation of the gradient of the error function at each iteration step, we must guarantee the continuity and differentiability of the error function. Obviously we have to use a kind of a activation function. Here we are using sigmoid function as activation function. Multilayered networks are capable of computing a wider range of Boolean functions than networks with a single layer of computing units. However the computational effort needed for finding the correct combination of weights increases substantially when more parameters and more complicated topologies are considered. In this chapter we discuss a popular learning method capable of handling such large learning problems —the back propagation algorithm. This numerical method was used by different research communities in different

contexts, was discovered and rediscovered, until in 1985 it found its way into connectionist AI mainly through the work of the PDP group. It has been one of the most studied and used algorithms for neural networks learning ever since.

**A. Estimation of Weighted Value of Average Fundamental Load Active and Reactive Power Components**

The back propagation algorithm looks for the minimum of the error function in weight space using the method of gradient descent. This method is not only more general than the usual analytical derivations, which handle only the case of special network topologies, but also much easier to follow. The combination of weights which minimizes the error function is considered to be a solution of the learning problem. Since this method requires computation of the gradient of the error function at each iteration step, we must guarantee the continuity and differentiability of the error function. Obviously we have to use a kind of activation function other than the step function used in perceptrons, because the composite function produced by interconnected perceptrons is discontinuous, and therefore the error function too.

A BP training algorithm is mainly used to estimate the three phase weighted value of load active power current components ( $wap$ ,  $wbp$ , and  $wcp$ ) and reactive power current components ( $waq$ ,  $wbq$ , and  $wcq$ ) from the polluted load currents using the feedforward and supervised principle. In this estimation, the input layer for three phases is given as follows

$$ILap = wo + iLauap + iLbubp + iLcucp \quad (1)$$

$$ILbp = wo + iLbubp + iLcucp + iLauap \quad (2)$$

$$ILcp = wo + iLcucp + iLauap + iLbubp \quad (3)$$

where  $wo$  is the selected value of the initial weight and  $uap, ubp$ , and  $ucp$  are the in-phase unit templates.

The In-phase unit templates are estimated using the sensed PCC phase voltages ( $vsa$ ,  $vsb$ , and  $vsc$ ). It is the relation of the phase voltage and the amplitude of the PCC voltage ( $vt$ ). The amplitude of sensed PCC voltages is estimated as

$$vt = \sqrt{\frac{2(vsa^2 + vsb^2 + vsc^2)}{3}}$$

The extracted values of  $ILap$ ,  $ILbp$ , and  $ILcp$  are passed through a sigmoid function as an activation function, and the output signals ( $zap$ ,  $zbp$ , and  $zcp$ ) of the feedforward section are mostly expressed as

$$Zap = f(ILap) = 1/(1 + e^{-ILap}) \quad (6)$$

$$Zbp = f(ILbp) = 1/(1 + e^{-ILbp}) \quad (7)$$

$$Zcp = f(ILcp) = 1/(1 + e^{-ILcp}) \quad (8)$$

The estimated values of  $zap$ ,  $zbp$ , and  $zcp$  are fed to a hidden layer as input signals. Differentiable activation functions the back propagation algorithm looks for the minimum of the error function. The three phase outputs of this layer ( $iap1$ ,  $ibp1$ , and  $icp1$ ) before the activation function are expressed as

$$iap1 = uo1 + uapzap + ubpzbp + ucpszcp \quad (9)$$

$$ibp1 = uo1 + ubpzbp + ucpszcp + uapzap \quad (10)$$

$$icp1 = uo1 + ucpszcp + uapzap + ubpzbp \quad (11)$$

where  $uo1$ ,  $uap$ ,  $ubp$ , and  $ucp$  are the selected value of the initial weights in the hidden layer and the updated values of three phase weights using the average weighted value ( $wp$ ) of the active power current component as a feedback signal, respectively. The updated weight of phase "a" active power current components of load current "wap" at the  $n$ th sampling instant is expressed as

$$wap(n) = wp(n) + \mu \{wp(n) - wap1(n)\} f(iap1)zap(n) \quad (12)$$

where  $wp(n)$  and  $uap(n)$  are the average weighted value of the active power component of load currents and the updated weighted value of phase "a" at the  $n$ th sampling instant, respectively, and  $wap1(n)$  and  $zap(n)$  are the phase "a" fundamental weighted amplitude of the active power component of the load current and the output of the feedforward section of the algorithm at the  $n$ th instant, respectively.  $f(iap1)$  and  $\mu$  are represented as the derivative of  $iap1$  components and the learning rate.

Similarly, for phase “b” and phase “c,” the updated weighted values of the active power current components of the load current are given as follows

$$wbp(n) = wp(n) + \mu \{wp(n) - wbp1(n)\} f(lbp1) zbp(n) \quad (13)$$

$$wcp(n) = wp(n) + \mu \{wp(n) - wcp1(n)\} f(lcp1) zcp(n). \quad (14)$$

The extracted values of  $l_{ap1}$ ,  $l_{bp1}$ , and  $l_{cp1}$  are then passed through a sigmoid function which is an activation function for the estimation of the fundamental active components in terms of three phase weights  $u_{ap1}$ ,  $u_{bp1}$ , and  $u_{cp1}$  as

$$u_{ap1} = f(l_{ap1}) = 1 / (1 + e^{-l_{ap1}}) \quad (15)$$

$$u_{bp1} = f(l_{bp1}) = 1 / (1 + e^{-l_{bp1}}) \quad (16)$$

$$u_{cp1} = f(l_{cp1}) = 1 / (1 + e^{-l_{cp1}}). \quad (17)$$

#### IV. SIMULATION RESULTS AND DISCUSSION

The DSTATCOM performance is depends upon the accurateness of harmonic current detection. For reducing ripple in compensating currents, the tuned values of interfacing inductors ( $L_f$ ) are connected at the output of an ac Voltage Source Converter. A three phase series combination of a resistor ( $R_f$ ) and capacitor ( $C_f$ ) correspond to the shunt passive ripple filter which is associated at a point of common coupling (PCC) for reducing the high frequency switching noise of the VSC. The currents ( $i_{cabc}$ ) of DSTATCOM are injected as required compensating currents to cancel the reactive power components and harmonics of the load currents so that loading due to reactive power component/harmonics is reduced on the distribution system.

##### (i) Performance of DSTATCOM in PFC Mode

The dynamic execution of a VSC-based DSTATCOM is considered for PFC mode at nonlinear burdens. The execution files are the stage voltages at PCC (versus), adjusted source streams (is), burden ebbs and flows (iLa, iLb, and iLc), compensator ebbs and flows (iCa, iCb, and iCc), and

dc transport voltage (vdc) which are appeared in Fig. under fluctuating burden (at  $t = 3.7$  to  $3.8$  s) conditions.

The waveforms of the stage "a" voltage at PCC (vsa), source current (isa), and burden current (iLa) are appeared in Fig3. The total harmonic distortion (THD) of the stage "an" at PCC voltage, source current, and burden current are observed to be 3.90%, 2.00%, and 27.90%, separately. It is watched that the DSTATCOM has the capacity perform the elements of burden adjusting and harmonic disposal with high accuracy.

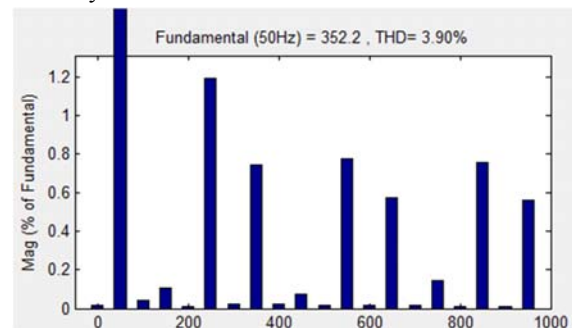

Fig a. PCC voltage of phase “a”

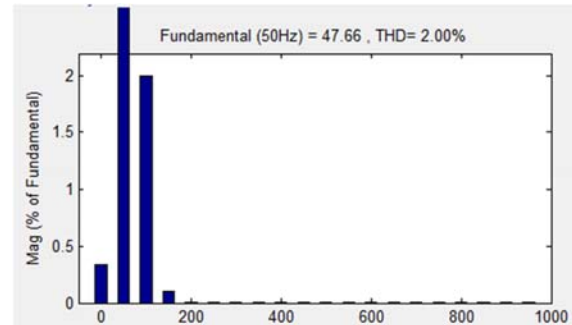

Fig b. source current of phase “a”

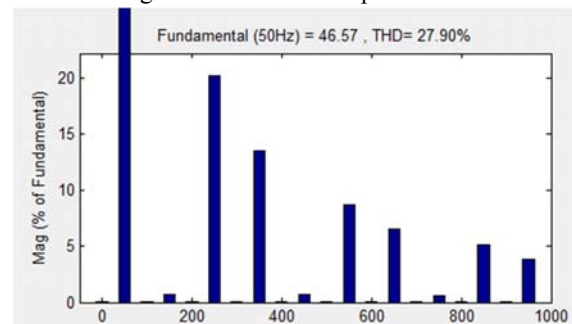

Fig c. load current of phase “a”

##### (ii) Performance of DSTATCOM in ZVR Mode

In ZVR mode, the amplitude of the PCC voltage is managed to the reference sufficiency by infusing additional driving receptive force segments. The dynamic execution of DSTATCOM as far as PCC stage voltages (versus), adjusted source streams (is), burden ebbs and flows (iLa, iLb, and iLc), compensator ebbs and flows (iCa, iCb, and iCc), amplitude of voltages at PCC (vt), and dc transport voltage (vdc) waveforms is appeared in Fig. under uneven burden at once span of  $t = 3.7$  to  $3.8$  s. The consonant spectra of the stage "a" voltage at PCC (vsa), source current (isa), and burden current (iLa) are appeared in Fig.. The THDs of the stage "an" at PCC voltage, source current, load current are seen to be 4.63%, 2.50%, and 28.88%, individually. Three stage PCC voltages are directed up to the appraised esteem. The amplitude of the three stage voltages is controlled from 335.2 to 338.9 V under nonlinear burdens.

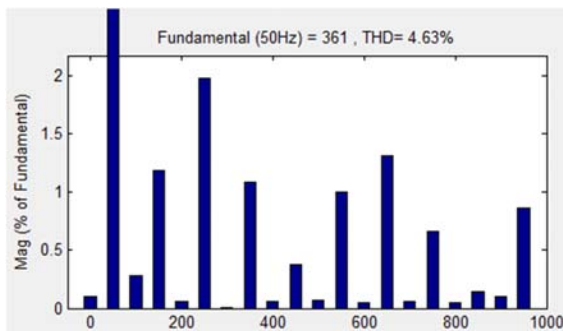

Fig d. PCC voltage of phase "a"

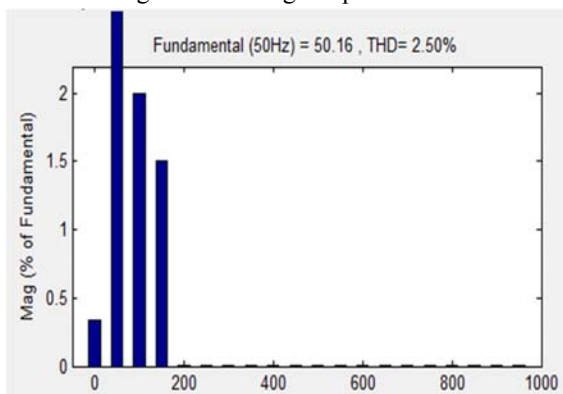

Fig e. source current of phase "a"

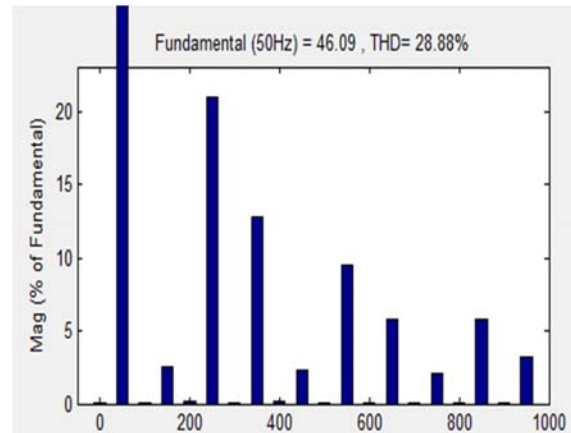

Fig f. load current of phase "a"

### (iii) Performance of UPFC in PFC mode

The dynamic performance of UPFC for PFC mode at non linear loads is shown in the below fig. The performance indices are the phase voltages at PCC ( $v_s$ ), balanced source currents ( $i_s$ ), load currents ( $i_{La}, i_{Lb}, i_{Lc}$ ) and compensator currents ( $i_{Ca}, i_{Cb}, i_{Cc}$ ) and dc bus voltage ( $v_{dc}$ ) are shown below under varying load during the time duration 3.7 to 3.8s. The results are found to be satisfactory when compared to DSTATCOM as there is a visible decrease in the THD which is the main objective of the project. The total harmonic distortion of the phase "a" at PCC voltage is 0.01%, the THD of load current of phase "a" is observed as 2.57% and finally the THD of source current is found to be 0.86%.

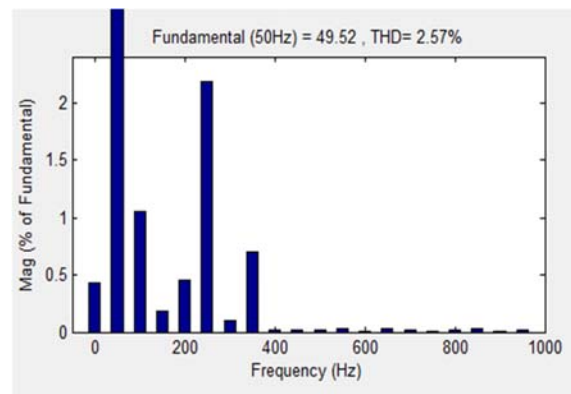

fig g. load current of phase "a"

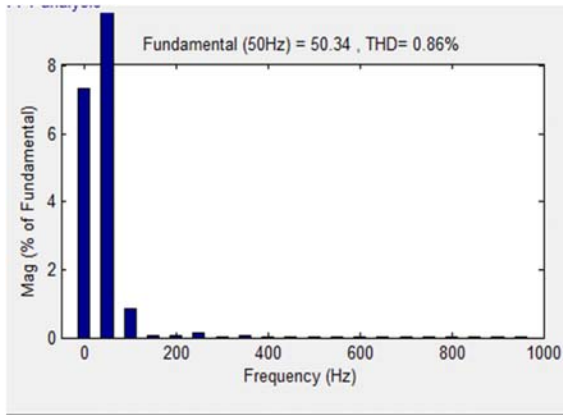

Fig h. Source current of phase a “ $i_{sa}$ ”

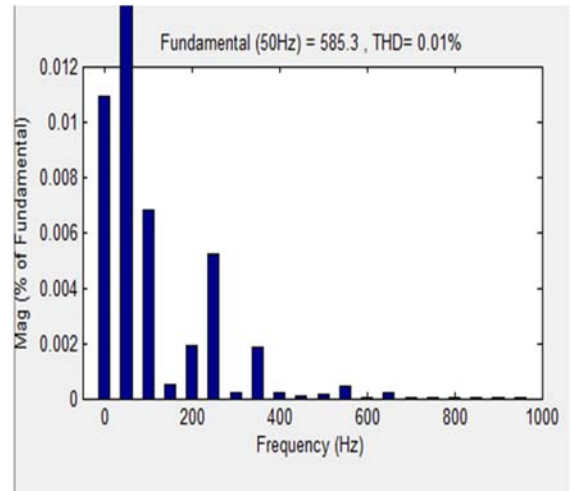

Fig i. PCC voltage of phase a “ $v_{sa}$ ”

**(iv) Dynamic Performance of UPFC under varying non linear loads in PFC mode**

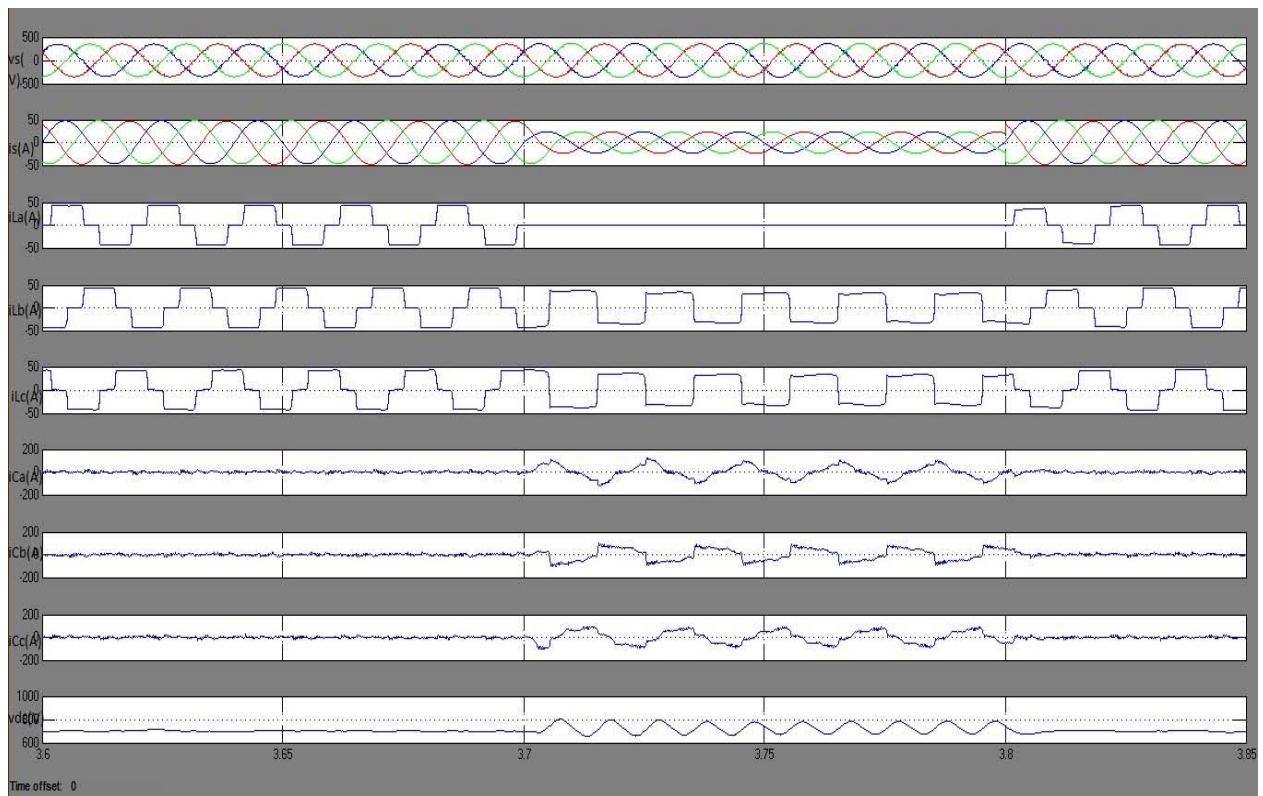



Fig 3. Performance of UPFC under nonlinear loads in PFC mode  $i_{sa}$ ,  $i_{sb}$ , and  $i_{sc}$  with  $v_{ab}$ ;  $i_{La}$ ,  $i_{Lb}$ , and  $i_{Lc}$ ; and  $i_{Ca}$ ,  $i_{Cb}$ , and  $i_{Cc}$ . Harmonic spectra of  $i_{sa}$ ,  $i_{La}$ , and  $v_{ab}$ .

The dynamic performance of UPFC is conducted for power factor correction (PFC) mode at non linear loads. The following are the performance indices, the phase voltages at PCC ( $v_s$ ), balanced source currents ( $i_s$ ), load currents ( $i_{La}$ ,  $i_{Lb}$ ,  $i_{Lc}$ ) and the compensator currents ( $i_{Ca}$ ,  $i_{Cb}$ ,  $i_{Cc}$ ) and the dc bus voltage ( $v_{dc}$ ) under varying loads during the time period 3.7 to 3.8s.

**(v) Performance of UPFC under Zvr mode**

In zvr mode the amplitude of the point of common coupling (pcc) voltage is regulated to the reference amplitude by injecting extra leading reactive power components. The dynamic performance of UPFC in terms of PCC voltages ( $v_s$ ), balanced source currents ( $i_s$ ), load currents ( $i_{La}$ ,  $i_{Lb}$ ,  $i_{Lc}$ ), compensator currents ( $i_{Ca}$ ,  $i_{Cb}$ ,  $i_{Cc}$ ), amplitudes of voltages at  $v_t$  and dc bus voltage ( $v_{dc}$ ) waveforms are shown in below fig under unbalanced load at a time duration  $t=3.7$  to 3.8s.

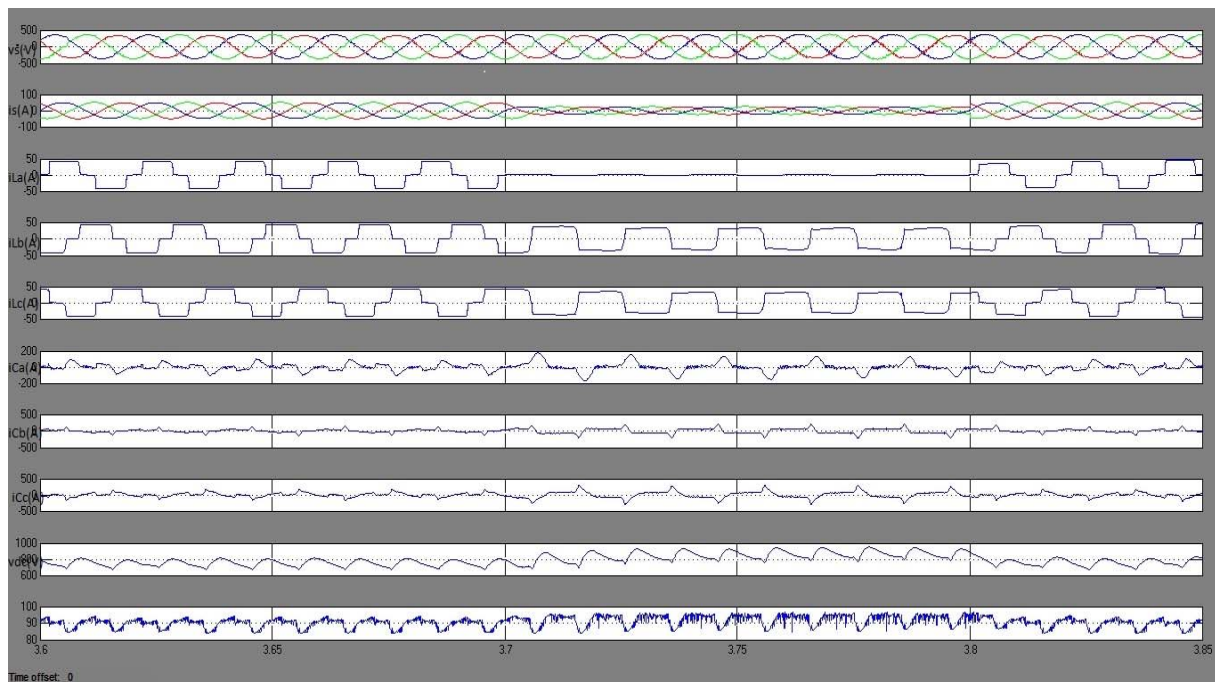

Fig. 4 Performance of UPFC under nonlinear loads in ZVR mode:  $i_{sa}$ ,  $i_{sb}$ , and  $i_{sc}$  with  $v_{ab}$ ;  $i_{La}$ ,  $i_{Lb}$ , and  $i_{Lc}$ ; and  $i_{Ca}$ ,  $i_{Cb}$ , and  $i_{Cc}$  Harmonic spectra of  $i_{sa}$ ,  $i_{La}$ , and  $v_{ab}$ .

These results shows satisfactory performance of UPFC for harmonic elimination and load balancing of non linear loads as according to IEEE-519

standard limit there is permissible amount of 5% in errors.

**(vi) Performance of UPFC at non linear loads**

The fig below shows the waveform and harmonic spectra and from these the total harmonic distortion (THD) is calculated. The results are as follows: The harmonic distortion of the “a” phase source current is observed as 1.59%, the harmonic distortion of load current is observed as 2.34% and the harmonic distortion of PCC voltage is observed as 0.01%. These results show better performance of the BP algorithm for harmonic elimination.

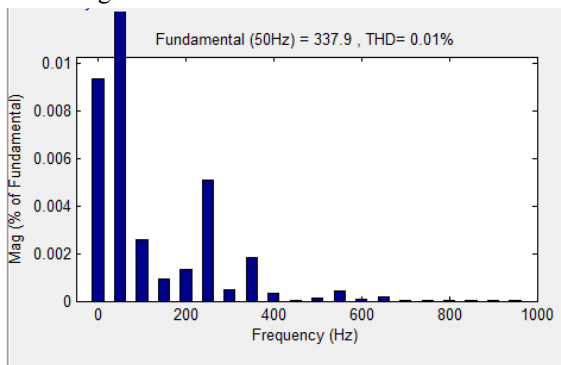

Fig j. PCC voltage of phase “a”

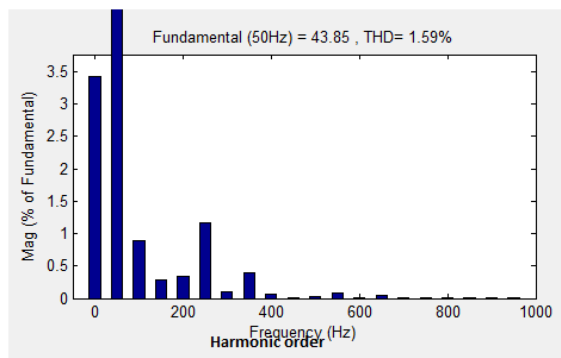

Fig k. Source current of phase “a”

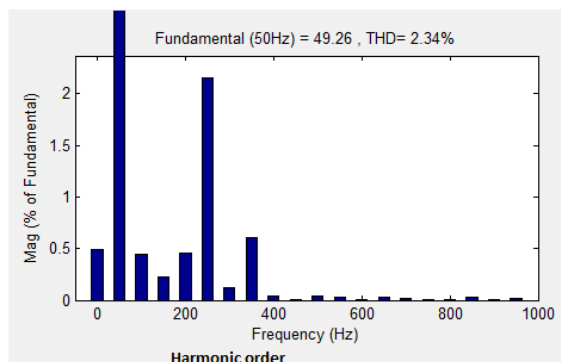

fig l. Load current of phase “a”

(V) TABLE 1

Performance of DSTATCOM and UPFC

Device	Mode	Performance parameters	Non linear load (rectifier with R and L load)
DSTATCOM	PFC	PCC Voltage	352.2V, 3.90%
	ZVR	Supply Current	47A, 66, 2.00%
		Load current	46.57A, 27.90%
		PCC Voltage	361V, 4.63%
UPFC	PFC	Source current	50.16A, 2.50%
	ZVR	Load current	46.09A, 28.88%
		PCC Voltage	585.3V, 0.01%
		Supply Current	50.34A, 0.86%
		Load Current	49.52A, 2.57%
		PCC voltage	337.9V, 0.01%
		Source Current	43.85A, 1.59%
		Load Current	49.26A, 2.34%

## VI. CONCLUSION

This paper presents a comparison between two custom power devices. They are DSTATCOM and UPFC. The comparison is made by using ANN (artificial neural networks). In artificial neural network we are using back propagation control algorithm. The reactive power and unbalanced currents are eliminated by using DSTATCOM. So here compensation of harmonics in distribution systems is carried out. A neural network has been proposed to predict the next step value of the output power on the basis of the values of the control input and output power at preceding instants. Back Propagation control algorithm and ILST are the two types of control algorithm that are generally used for the extraction of reference source currents. The thesis mainly concentrated on two important effects of power quality. The first one is the current harmonic and the second one is load voltage harmonics. To design the alternative control schemes for switching of the shunt active power filter artificial neural

network and fuzzy logic controllers are used. The various activities that are performed by DSTATCOM are transients elimination and balancing of unbalanced loads. Various that has been demonstrated in Zero Voltage Regulation and Power Factor Correction modes of DSTATCOM with dc voltage regulation. For the compensation or suppression of harmonics in nonlinear loads the DSTATCOM shows a satisfactory performance which can be seen in the simulation results of DSTATCOM. The performance has been found better for this application because the extracted reference source currents exactly traced out, that means compensated the sensed source currents during the steady state as well as dynamic conditions i.e., under fluctuating conditions of the distribution system. Although the implemented methods provide the distortion levels within the specified IEEE standards (that means 5% of harmonics are allowed) achieving balanced load currents from the unbalanced system was a difficult task which leads to the flow of neutral current. The other problem that we have overcome here is without any overshoots/undershoots we have regulated the DC bus voltage of the DSTATCOM to the rated value. The description of the BP control algorithm is carried out by the simulation results under non linear loads. It can also be said that a DSTATCOM though it is conceptually similar to a STATCOM at the transmission level, its control scheme should be such that in addition to complete reactive power compensation, power factor correction and total harmonic distortion are also checked. The results are also verified for UPFC. Thus, the two objectives of the thesis were attained by modeling and simulating the neutral compensator and UPFC. Therefore the proposed method made an enhancement in the power quality in the distribution system.

## VII. REFERENCES

- [1] R. C. Dugan, M. F. McGranaghan, and H. W. Beaty, *Electric Power Systems Quality*, 2nd ed. New York, NY, USA: McGraw-Hill, 2006.
- [2] A. Ortiz, C. Gherasim, M. Manana, C. J. Renedo, L. I. Eguiluz, and R. J. M. Belmans, "Total harmonic distortion decomposition depending on distortion origin," *IEEE Trans. Power Del.*, vol. 20, no. 4, pp. 2651–2656, Oct. 2005.
- [3] T. L. Lee and S. H. Hu, "Discrete frequency-tuning active filter to suppress harmonic resonances of closed-loop distribution power systems," *IEEE Trans. Power Electron.*, vol. 26, no. 1, pp. 137–148, Jan. 2011. 1212 IEEE TRANSACTIONS ON INDUSTRIAL ELECTRONICS, VOL. 61, NO. 3, MARCH 2014
- [4] K. R. Padiyar, *FACTS Controllers in Power Transmission and Distribution*. New Delhi, India: New Age Int., 2008.
- [5] *IEEE Recommended Practices and Requirement for Harmonic Control on Electric Power System*, IEEE Std. 519, 1992.
- [6] T.-L. Lee, S.-H. Hu, and Y.-H. Chan, "DSTATCOM with positive sequence admittance and negative-sequence conductance to mitigate voltage fluctuations in high-level penetration of distributed generation systems," *IEEE Trans. Ind. Electron.*, vol. 60, no. 4, pp. 1417–1428, Apr. 2013.
- [7] B. Singh, P. Jayaprakash, and D. P. Kothari, "Power factor correction and power quality improvement in the distribution system," *Elect. India Mag.*, pp. 40–48, Apr. 2008.
- [8] J.-C. Wu, H. L. Jou, Y. T. Feng, W. P. Hsu, M. S. Huang, and W. J. Hou, "Novel circuit topology for three-phase active power filter," *IEEE Trans. Power Del.*, vol. 22, no. 1, pp. 444–449, Jan. 2007.
- [9] Z. Yao and L. Xiao, "Control of single-phase grid-connected inverters with nonlinear loads," *IEEE Trans. Ind. Electron.*, vol. 60, no. 4, pp. 1384–1389, Apr. 2013.
- [10] A. A. Heris, E. Babaei, and S. H. Hosseini, "A new shunt active power filter based on indirect matrix converter," in *Proc. 20th Iranian Conf. Elect. Eng.*, 2012, pp. 581–586.