

# Methods to reduction of inter carrier interference (ICI) in OFDM: A Review

**Author \_Er.Sukhjit singh**

AP ECE,GJIET Banur,Punjab(India)

[sukhjit43@gmail.com](mailto:sukhjit43@gmail.com)

## Abstract—

*Orthogonal Frequency division multiplexing(OFDM) is promising technique for broadband wireless communication system. Intercarrier interference (ICI) occurs in OFDM which must be removed. There are various methods to reduce ICI in OFDM . In this paper we will discuss these various methods like maximum likelihood Estimation(MLE), self cancellation (SC),Extended Kalman filtering (EKF) ,Time domain window ,frequency domains window techniques, and channel estimation techniques .*

**Keywords—**Orthogonal frequency division multiplexing (OFDM) Inter carrier interference(ICI); self cancellation (SC);Extended Kalman filtering (EKF) ;The least-square (LS) and minimum-mean-square-error (MMSE); Discrete furrier Transform( DFT)

## I.Introduction

In a basic communication system, the data are modulated onto a single carrier frequency. The available bandwidth is then totally occupied by each symbol. This kind of system can lead to inter-symbol-interference (ISI). OFDM is a frequency division multiplexing technique used as a multi carrier modulation method. Because of high capacity transmission of OFDM, it has been applied to digital transmission system, such as digital audio broadcasting (DAB) system, digital video broadcasting TV (DVB-T) system. The basic principle of OFDM is to split a high rate data-stream into multiple lower rate data streams that are transmitted simultaneously over a number of sub carriers. OFDM uses the spectrum much more efficiently by spacing the channels much closer. This is

achieved by making all the carriers orthogonal to one another, preventing interference between the closely spaced carriers. OFDM sends multiple high-speed signals concurrently on orthogonal carrier frequencies. This results much more efficient use of bandwidth as well as robust communications during noise and other interferences

The block diagram of OFDM system is given in figure 1 as shown

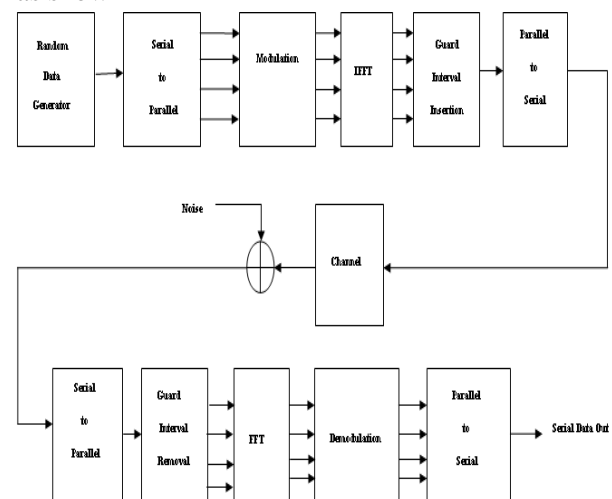

Fig.1

The high speed data rates for OFDM are accomplished by the simultaneous transmission of data at a lower rate on each of the orthogonal sub-carriers. Because of the low data rate transmission, distortion in the received signal induced by multi-path delay in the channel is not as significant as compared to single-carrier high-data rate systems. As a narrowband signal sent at a high data rate through a multipath channel will experience greater negative effects of the multipath delay spread, because the symbols are much closer

together. Multipath distortion can also cause inter-symbol interference (ISI) where adjacent symbols overlap with each other. This is prevented in OFDM by the insertion of a cyclic prefix between successive OFDM symbols. This cyclic prefix is discarded at the receiver to cancel out ISI.

## II. INTERCARRIER

There exists two problems with OFDM, first one is high peak to average power ratio and other is its sensitivity to frequency offset between the transmitted and received signals, which may be caused by Doppler shift due to relative motion between transmitter and receiver, or by the difference between the transmitter and receiver local oscillator frequencies. This carrier frequency offset causes loss of orthogonality between sub-carriers and then the signals transmitted on each carrier are not independent of each other. The orthogonality of the carriers is no longer maintained, which results in inter-carrier interference. ICI problem would become more complicated when the multipath fading is present. If ICI is not properly compensated it results in a power leakage among the sub carriers, thus this degrades the system performance. The various methods that can be used to minimize the ICI are frequency domain equalization, time domain windowing scheme, ICI self cancellation scheme, maximal likelihood estimation, extended kalman filtering etc.

## III. METHODS TO REDUCE ICI

### A. ICI Self- Cancellation Method

In ICI Self- Cancellation method, at the transmitter side, one data symbol is modulated onto a group of adjacent subcarriers with a group of weighting coefficients. The weighting coefficients are designed so that the ICI caused by the channel frequency errors can be minimized. At the receiver side, by linearly combining the received signals on these subcarriers with proposed coefficients, the residual ICI contained in the received signals can then be

further reduced. This method is suitable for multipath fading channels.

### B. Maximal Likelihood Estimation :

This method was suggested by Moose. This method estimates the frequency offset and cancels this offset at the receiver. In this technique, an OFDM symbol stream of  $N$  symbols is replicated such that the duplicate symbols are  $N$  positions apart in the symbol stream. These symbols are then modulated using a  $2N$ -point inverse fast Fourier transform. At the receiver, the first set of  $N$  symbols are demodulated using an  $N$ -point fast Fourier transform to yield the sequence  $Y_{1k}$ , and the second set is demodulated with another  $N$ -point FFT to yield the sequence  $Y_{2k}$ . The frequency offset is the phase difference between  $Y_{1k}$  and  $Y_{2k}$ , that is,  $Y_{2k} = Y_{1k} e^{j2\pi \epsilon}$ .

Once the frequency offset is known, the ICI distortion in the data symbols can be reduced by multiplying received symbols with a complex conjugate of the frequency shift.

C. **Extended Kalman Filter** : The Extended Kalman Filtering (EKF) technique is another method to estimate the frequency offset in the received signal. The received symbols are

$$Y(n) = X(n) \cdot e^{\frac{j2\pi n' \epsilon(n)}{N}} + W(n) \quad (2)$$

There are two stages in the EKF scheme to mitigate the ICI effect: the offset estimation scheme and the offset correction scheme.

D. **Time Domain Window Method**: When the signal is transmitted in a band limited channel, certain portion of the signal spectrum will be cut off, which will cause ICI occurrence. To overcome the interference the spectrum of the signal wave form need to be more concentrated. This is achieved by windowing the signal. Windowing is the process of multiplying a suitable function to the transmitted signal wave form. The same window is used in the receiver side to get back the original signal. The

time domain window method reduces the ICI caused by band limited channel but this is not major source of ICI. This method introduces the problem of noise enhancement.

**E. Frequency Domain Equalization:** frequency domain equalization process is used for reduction of ICI by using suitable equalization techniques. This technique can only reduce the ICI caused by fading distortion which is not the major source of ICI. This method is only suitable for flat fading channels, but not in wireless communication channels that are frequency selective fading in nature because of multipath components.

**F. Channel estimation Techniques:** The channel estimation can be performed by either inserting pilot tones into all of the subcarriers of OFDM symbols with a specific period or inserting pilot tones into each OFDM symbol. The first one, block type pilot channel estimation, has been developed under the assumption of slow fading channel. The Second one is Comb-type pilot channel estimation. In this type, every OFDM symbol has pilot tones at the periodically-located subcarriers, which are used for a frequency-domain interpolation to estimate the channel along the frequency axis. And third one is Lattice Type in which pilot tones are inserted along both the time and frequency axes with given periods. The pilot tones scattered in both time and frequency axes facilitate time/frequency-domain interpolations for channel estimation.

#### G. Training Symbol-Based Channel Estimation

Training symbols can be used for channel estimation, usually providing a good performance. However, their transmission efficiencies are reduced due to the required overhead of training symbols such as preamble or pilot tones that are transmitted in addition to data symbols. The least-square (LS) and minimum-mean-square-error (MMSE) techniques are widely used for channel estimation when training symbols are available

#### H. DFT-Based Channel Estimation

The DFT-based channel estimation technique has been derived to improve the performance of LS or MMSE channel estimation by eliminating the effect of noise

outside the maximum channel delay. Figure 2 shows a block diagram of DFT-based channel estimation. The DFT-based channel estimation technique has been derived to improve the performance of LS or MMSE channel estimation by eliminating the effect of noise outside the maximum channel delay.

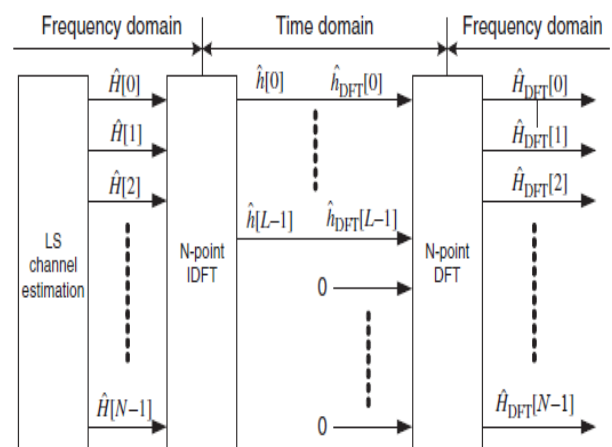

Fig.2

#### IV. CONCLUSIONS

In this paper we investigate the ICI in OFDM by various method. The self cancellation method is simple method to reduce ICI, Extended Kalman Filtering is does not reduce bandwidth as in self –cancellation method. The time domains and frequency domains methods are used to reduce ICI. The further work can be done by extending the concept of self-cancellation and by performing the simulation to investigate the performance of these ICI cancellation schemes in multipath fading.

#### V. REFERENCES

- [1] Weinstein,S.; Ebert, P. “Data Transmission by Frequency Division Multiplexing Using the Discrete Fourier Transform” IEEE Transactions on Communications, vol.19, 1971.
- [2] Y.Zhao and S. Häggman, “Inter carrier interference self cancellation scheme for OFDM mobile

- communication systems,” IEEE Transactions on Communications, vol. 49, no. 7, 2001.
- [3] Yi-Hao Peng; Ying-Chih Kuo; Gwo-Ruey Lee; Jyh-Horng Wen,”Performance Analysis of a New ICI-Self-Cancellation-Scheme in OFDM Systems”, vol.53, pages 1333 - 1338 ,2007.
- [4] Hen-Geul Yeh; Yuan-Kwei Chang; Hassibi, B.;“A Scheme for Cancelling Intercarrier Interference using Conjugate Transmission in Multicarrier Communication Systems”, vol.6, pages 3-7, 2007.
- [5] Niranjane, V.B.Bhoyar, D.B. “Performance Analysis of Different Channel Estimation Techniques” Page: 74 – 78, 2011.
- [6] P. H. Moose, “A Technique for Orthogonal Frequency Division Multiplexing Frequency Offset Correction,” IEEE Transactions on Communications, vol. 42, no. 10, 1994.
- [7] Allam Mousa<sup>1</sup>, Hala Mahmoud, “Reducing ICI effect in OFDM system using low complexity Kalman filter based on comb-type pilots arrangement”, vol.24, page: 53-61, 2010.
- [8] Senevirathna, S.B.; Jayawardena, C.; Perera, S.S.; Perera, C.L.; Ranasignhe, D.; Wijerathna, S.R.; Bandara, T.N.”Carrier Frequency Offset Estimation for OFDM System using Extended Kalman Filter”, Page(s): 351 – 354, 2008.
- [9] B.Sathish Kumar K.R.Shankar Kumar R.Radhakrishnan “An Efficient Inter Carrier Interference Cancellation Schemes for OFDM Systems”, (IJCSIS) International Journal of Computer Science and Information Security, Vol. 6, No. 3, 2009.
- [10] V.Jagan Naveen and K.RajaRajeswari,“ICI Reduction using Extended Kalman Filter in OFDM System”, vol.17, No.7, 2011.
- [11] Colieri, S.; Ergen, M.; Puri, A.; Bahai A., “Study of Channel Estimation in OFDM Systems”Page: 894 – 898, vol.2, 2002.
- [12] Theodore S. Rappaport, Wireless Communications Principles and Practice, 2<sup>nd</sup> ed. Dec 31, 2001.