

Design & Simulation of Grid Integration of Renewable Energy Sources Using High Frequency Link Cascade Multilevel Inverter

M.Jaya Madhuri¹ & K.Kranthi Pratap Singh²

¹M.Tech Scholar, Dept of EEE, ASR College of Engineering and Technology, JNTUK, A.P

²Assistant Professor, Dept of EEE, ASR College of Engineering and Technology, JNTUK, A.P

Abstract: —

This paper presents a High-frequency link multilevel cascaded medium voltage converter. Medium-voltage converters eliminate the step-up transformer for direct grid integration of renewable power plants, but MMC converters require multiple DC supplies. The high frequency magnetic link is used to generate the multiple isolated DC sources for all H-bridge inverter cells of the MMC converters and it also minimizes the voltage imbalance, common mode issue. The proposed system performance is analyzed in the MATLAB/Simulink environment. It is expected that the proposed new technology will have great potential for future renewable power generation and smart grid application. Finally, the proposed new topology is simulated by MATLAB/Simulink software to validate the accuracy of the theoretical explanation.

Keywords: Pulse Width Modulation (PWM); Direct grid integration; high frequency link; medium-voltage converters; modular multilevel cascaded converters; Renewable Energy Systems(RES)

I. INTRODUCTION

The interest in renewable-energy sources is successively increasing because of rising demand of the world's energy and increasing price of the other energy sources, together with considering the environmental pollution. Many renewable energy sources are now available; among them, PV is the most up-to-date technique to address the energy problems. Photovoltaic (PV) power generation systems are received more and more attention in recent years. Due to the large-scale manufacturing capability of the PV module, it is becoming increasingly cheaper during these last years. So the

attempt to decrease the total grid-tied PV system cost is mostly depend on the price of grid-tied inverter [1-3]. Grid tied PV inverters which consists a line frequency transformer are large in size; make the entire system extensive and difficult to install. It is also a challenging task to increase the efficiency and reduce the cost by using high frequency transformer which requires several power stages [4, 5].

The energy and environment represents two major areas of current global crisis and it is more and more widely recognized that renewable energy sources, especially wind and solar energy, can offer effective solutions to these enormous challenges as the wind and solar power development is experiencing dramatic growth. Since 2007, medium- and large scale PV power have attracted great interest and PV power plants of more than 10 MW in capacity have now become a reality [1]. More than 200 PV power plants have been installed in the world, each of them generating an output more than 10 MW. In future some are to have a capacity in excess of 250 MW. These multi-megawatt PV power plants require large area of land. So they are usually installed in remote areas far from cities. However the renewable energy sources have highly variable daily and seasonal patterns and consumer power demands are also extremely variable in nature. Therefore it is difficult to operate a standalone power system which is supplied from only one renewable source unless there are appropriate energy storage facilities. For this grid integration is the only possible solution if enough storage facilities are not available.

Currently there are 318 GW of wind power generation installed worldwide. Wind farms cover large areas of land. The land area covered by a 3.6 MW turbine can be almost 0.37km², such that 54 turbines would cover about a land area of 20km².

Offshore wind farms can save land rental expense which is equivalent to 10-18% of total operating and maintenance cost of a wind farm, offshore based wind farms have attracted great attention in the last few years. To integrate scattered wind turbine generators to a medium-voltage a power frequency transformer is commonly used to step-up the voltage for long distances transmission. Fig.1. shows the traditional wind turbine with step-up transformer.

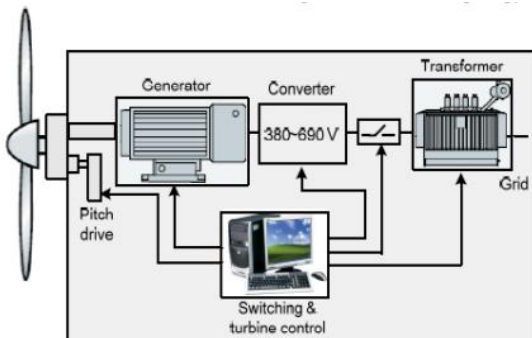

Fig.1. Fully rated converter based wind turbine generation system

With the fast development of power electronics, it is becoming a reality to replace the combination of low voltage inverter and step-up transformer by a medium voltage converter for direct grid connection to reduce the system volume and weight, as well as the cost. In comparison with the conventional two- and three- level converters, the multilevel converters present lower switching losses, lower voltage stress on the switching devices and higher equality output power, and thus suite better for medium-voltage applications. Although there are several multilevel converter topologies, because of (e.g. some special features like number of components scales linearly with the number of levels, and individual modules are identical and completely modular in construction hence enabling high level number attainability) the modular multilevel cascaded (MMC) converter topology can be considered as a possible candidate for the medium-voltage applications [3]-[7]. However the MMC converter requires multiple isolated and balanced DC sources [4]-[6]. As a result its application is not straight forward, especially in wind power generation.

To eliminate the step-up transformer of wind turbine generators, in 2008 a multicoil modular permanent magnet generator was proposed [12]. This multi winding generator has special winding arrangement and complicated control strategies to generate multiple DC supplies of the MMC converters. An improved control strategy was verified and is almost same generator converter system [13]-[14]. To eliminate the step-up transformer in 2010, another approach was proposed [15].

To generate multiple Dc supplies for the MMC converters a few six phase generators are placed in the nacelle. All the generators are driven by the same wind turbine and each stator winding generates an isolated source for an H-bridge inverter cell of the MMC converter. Even though these MMC converters generates medium-voltage ac outputs but these approaches requires special modular generators and multiple traditional generators to generate isolated multiple DC supplies for the MMC converters, and introduce electrical isolation problems between the generator and grid.

The quasi-Z source inverter has attracted significant attention in recent years due to some special features [10]-[11]. A medium-voltage PV inverter which is a combination of few quasi-Z source inverters into an MMC converter was proposed in 2012 [12], where the quasi-z source inverter generates dc supplies for the MMC converter, but it does not have electrical isolation between the PV array and medium-voltage grid. Multiple isolated high frequency link-based medium-voltage PV inverter topology was proposed [10]-[11] where the high frequency link generates dc supplies for the MMC converters. In these proposed systems voltage balancing is the challenging issue since each module is connected to a PV array through a dc/dc converter. A common dc link inverter was proposed in 2012 [11]-[12]. The proposed system may reduces the voltage imbalance problem in the grid side, but the generation of common dc-link voltage from different PV arrays makes the inverter operation complex and limits the range of maximum power point tracker (MPPT) operation.

Nowadays, it is common to use high-frequency magnetic links in designing grid-connected power electronic converters, which can provide electrical isolation without increasing system volume and weight [13]. For example, operated at 1.2 kHz, the weight and size of a 3 MW transformer can be less than 8% of an equivalent 50 Hz unit [15]. For fabrication of high-frequency transformer, the amorphous material has excellent magnetic characteristics such as high saturation flux density and relatively low specific core losses at medium to high frequencies [2]. The commercially available amorphous material is Metglas. The saturation flux density of the Metglas alloy 2605S3A is 1.41 T and the specific core loss at 10 kHz sinusoidal excitation of 0.5T is 20 W/kg.

In this paper, a high-frequency link cascaded medium-voltage converter is proposed for direct grid integration of renewable energy sources. Multiple isolated and balanced DC supplies are generated by the common magnetic link for all of the H-bridge inverter cells of the

MMC converter from a single or multiple renewable energy sources. The high frequency link multilevel cascaded medium-voltage converter-based grid integration will have the following advantages: 1) No requirement for special or multiple generators for the wind turbine generator system; 2) a wide range of MPPT operation for PV systems; 3) An inherent dc-link voltage balance due to the common magnetic-link; 4) Direct grid integration without using step-up transformer; 5) An inherent minimization of the grid isolation problems through the high-frequency link; 6) An overall compact and light weight system. To verify the feasibility of the proposed system a simulink model is developed with modular five-level cascaded converter which gives three phase 1kV rms as output.

II. PROPOSED TOPOLOGY – MEDIUM VOLTAGE CONVERTER BASED DIRECT GRID INTEGRATION SYSTEM

A. Basic block diagram of the proposed system :

In this paper, as an approach to eliminate the step-up transformer to integrate renewable sources to grid, an amorphous alloy 2605SA1-based common magnetic link is considered. The array dc power is converted to a medium frequency ac through a medium-frequency inverter. The inverter is also ensures constant output voltage. The inverter is connected to a primary winding of a multi winding high-frequency link. Each secondary winding works as an isolated source and is connected to an H-bridge cell through a bridge rectifier.

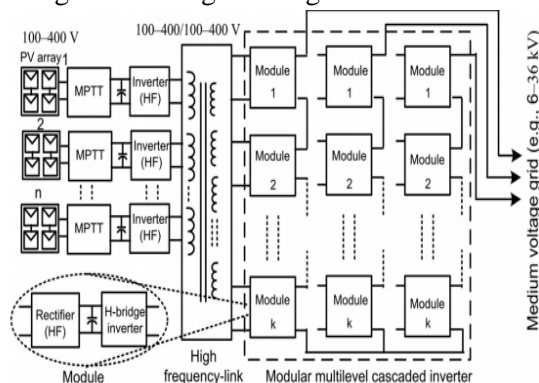

Fig.2. Proposed medium-voltage PV inverter system

The number of primary windings depends on the number of PV arrays and the number of secondary windings depends on the number of levels of the inverter. The detailed power circuit of a three-phase five level PV inverter system is shown in fig3. In large PV power plants,

several PV arrays are operated in parallel. For this case, multi input and multi output magnetic link can be used, where each PV is connected to a primary winding through a booster and medium-frequency inverter as shown in Fig2.

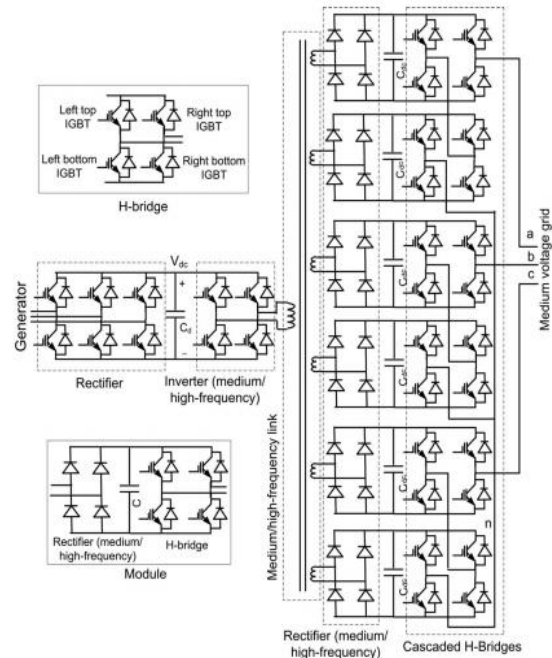

Fig.3. Detailed power conversion circuit

B. Design and Analysis of the Proposed System :

If m_l is the number of levels of the converter , the number of cascade modules on each phase can be calculated from

$$M_n = \frac{m_l - 1}{2} \quad (1)$$

If $V_{ll}(rms)$ is the grid line to line voltage, the minimum dc-link voltage of each H-bridge inverter cell can be calculated from

$$V_{dc(min)} = \sqrt{2} \frac{V_{ll}(rms)}{(m_l - 1)} \quad (2)$$

To determine the nominal dc-link voltage of each H-bridge inverter cell, a voltage reserve of 4% is assumed, i.e.,

$$V_{dc(nom)} = 1.04V_{dc(min)} \quad (3)$$

If $I_p(rms)$ is the inverter phase current ,the apparent output Power can be calculated from

$$S_c = \sqrt{3}V_{ll}(rms)I_p(rms) \quad (4)$$

The highest voltage rating of commercially available IGBT is 6.5 kV and, this is suitable for 2.5 kV

and lower voltage inverter systems with traditional two-level converter topology. Although high voltage devices such as 3.3-, 4.5-, and 6.5 kV IGBTs are available in the market, They are still costly as shown in Fig.4.

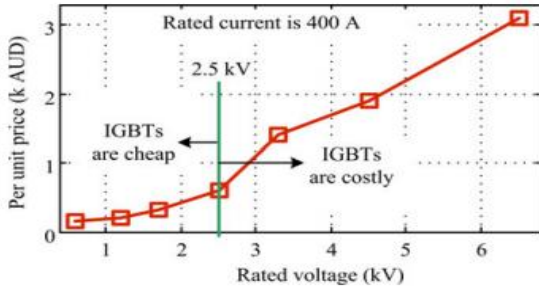

Fig.4. Market price of power semiconductor devices (IGBTs)

The lower voltage devices, such as 0.6-,0.9-,1.2-, 1.7- and 2.5 kV IGBTs are not only matured in technology but also relatively low in price. On the other hand the cascaded connection of low voltage rated semiconductors can be a cost effective solution for medium-voltage inverter applications [13]. The high-number of levels means that medium-voltage attainability is possible to connect the PV array to the medium-voltage ac network directly as well as possible to improve the output power quality. The total harmonic distortions (THD) of levels ranging from 7-level to 19-level with four modulation schemes (e.g., the phase shifted carriers with sinusoidal references (SPWM), the phase shifted carriers with third harmonic injected sinusoidal references (THPWM), the phase-shifted carrier with 600 modulated sinusoidal references (SDPWM), and the phase shifted carriers with trapezoidal type references (TRPWM) is illustrated in Fig.5.

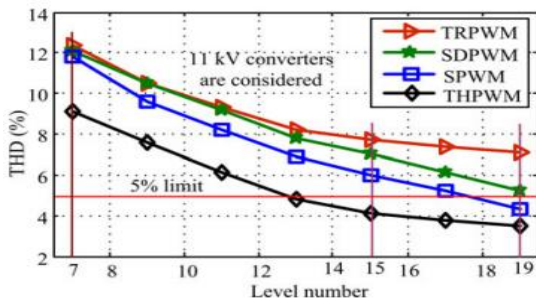

Fig. 5. Calculated THD at different number of levels ranging from 7-level to

19-level with four modulation techniques

Component number and control complexity increases linearly as the number of levels increases. Therefore, the optimal selection of the number of inverter levels is important in order to achieve the best performance/cost ratio of the PV systems. Each H-bridge cell commutation voltage of a seven-level topology-based 11 kV inverter is 2696 V, which may be supported by the 6.5 kV IGBT. Thus, at least seven-level topology is required to design the 11-kV inverter. The output power quality of a 21-level inverter is good enough to feed into the 11-kV ac grid directly. The low-price 1.7-kV IGBT can

be used to design the 21-level inverter. For a 33-kv system, at least 15-level topology is required and 55-level topology is sufficient for the power quality. Therefore, 7-level to 21-level MMC inverter topologies are considered for an 11-kV inverter system and 15-level to 55-level converter topologies are considered for the 33-kV system. The device voltage utilization factor (DVUF), ratio of commutation voltage of respective commutation cells (V_{dc} nom) and device commutation voltage for a device reliability of 100 failures in time (FIT) due to cosmic radiation ($V_{com@100FIT}$) are summarised in Table I. A higher DVUF is essential for the cost effective design, since the semiconductor cost is a significant figure for medium voltage inverter applications. From Table I, it can be seen that only a few inverters have high DVUFs. In order to ensure a cost effective design, the inverters with levels of number 9, 11, 15, 19, and 21 for an 11-kV system are considered for the further analysis. The number of arithmetic and logical operation (ALOs) for switching section and cost of semiconductors are calculated and summarized in table II. The THD is calculated through MATLAB/Simulink environment.

TABLE.I. SELECTION OF IGBT FOR MM CONVERTER

Level number	9	11	15	19	21
IGBTs	48	60	84	108	120
THD (%)	9.60	8.20	6.00	4.30	4.25
Cost (AUD)	86400	82159	50400	36670	40744
ALOs	44	55	77	99	110

TABLE.II. COMPARISON OF MM CONVERTERS

Level number	V_{com} (V)	Rated device voltage (kV)	$V_{com@100FIT}$ (V)	DVUF (%)
7	2696	6.5	3600	75
9	2022	4.5	2250	90
11	1618	3.3	1800	90
13	1348	3.3	1800	75
15	1156	2.5	1200	96
17	1011	2.5	1200	84
19	898	1.7	900	99
21	809	1.7	900	90

III. MATLAB BASED SIMULATION & RESULTS

To verify the feasibility of the proposed system a simulink model is developed with modular five-level cascaded converter which gives three phase 1kV rms as output. Fig.6, Fig.7 & Fig.9 shows the sub system in the simulink model.

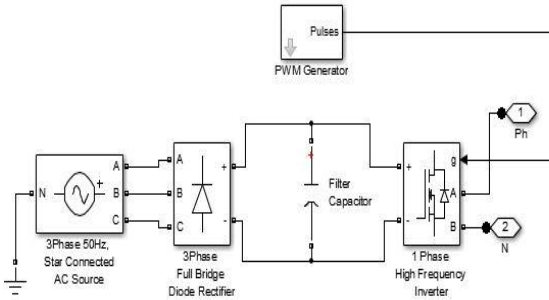

Fig.5. MATLAB based simulation diagram of proposed system with masked diagrams

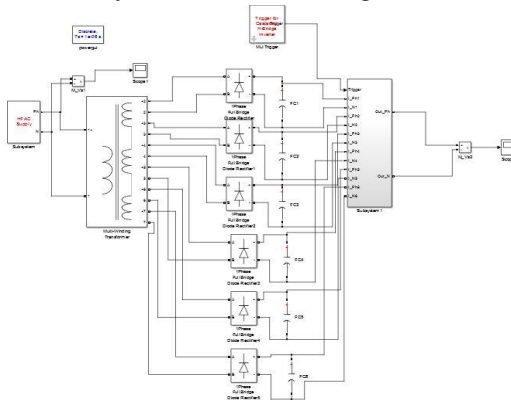

Fig.6. MATLAB based simulation diagram of proposed system with masked blocks

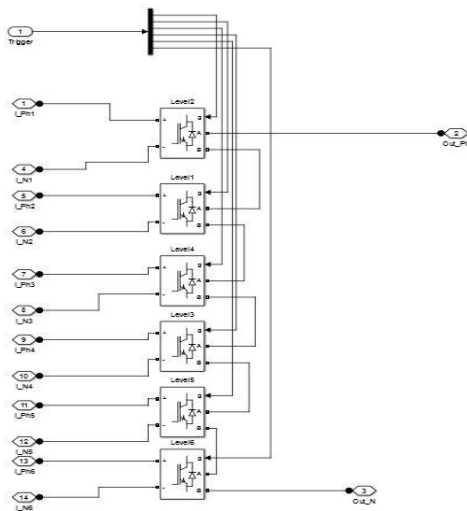

Fig.7. MATLAB based simulation diagram of proposed system with masked blocks

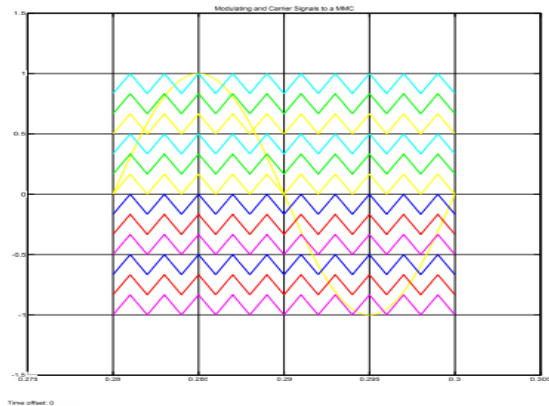

Fig.8. shows the MATLAB based simulation carrier signal

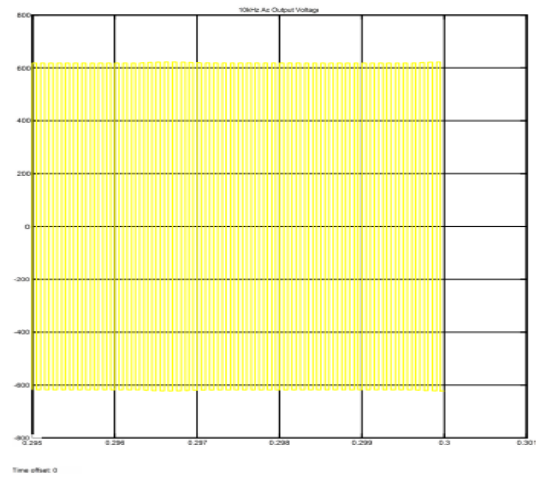

Fig.9. MATLAB based simulation voltage waveform diagram of proposed system

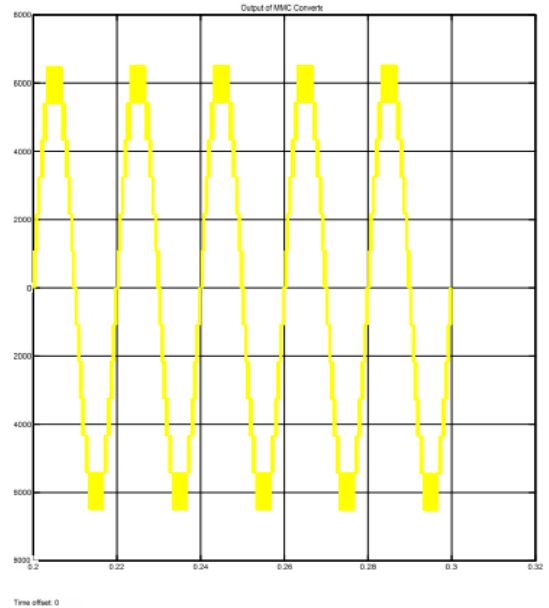

Fig.10. MATLAB based simulation output voltage waveform diagram of proposed system

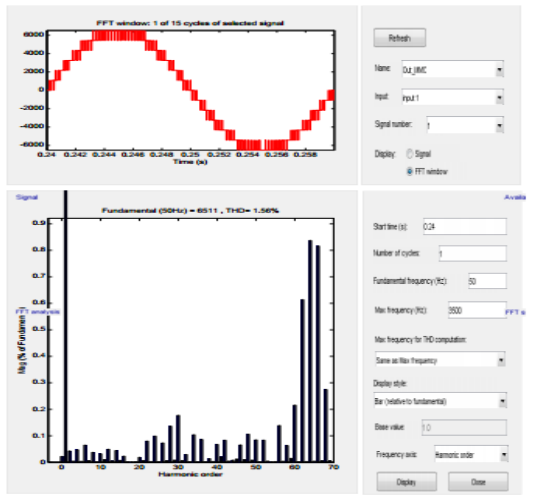

Fig.9. FFT Analysis window diagram

Table.III shows the simulation parameters for the proposed system

TABLE.III.SIMULATION SPECIFICATIONS

Parameter	Rating
Line Voltage (kV)	11
Line Current	250
Apparent Power (MVA)	4.76
Carrier frequency (kHz)	1-2
Output frequency (Hz)	20
Number of levels	7-21
Number of phases	3
Carrier shifting	Phase shifted

IV. CONCLUSION

In this paper, a new-medium voltage PV inverter system is proposed for medium – or large-scale PV power plants. A common magnetic link is employed to interconnect PV arrays to form a single source. Multiple isolated and balanced dc supplies for the multilevel inverter have been generated through the common magnetic link, which automatically minimizes the voltage imbalance problem. The grid isolation and safety problems have also been solved inherently due to electrical isolation provided by the

High-frequency link. Although the additional windings and rectifiers may increase loss of the proposed system, the overall performance is still similar to the traditional system. The elimination of line filter and step-up transformer from traditional system will enable the large cost savings in terms of the installation, running and maintenance of the PV power plant.

REFERENCES

- [1] M. R. Islam, Y. G. Guo, and J. G. Zhu, "A transformer-less compact and light wind turbine generating system for offshore wind farms," in *Proc. IEEE Int. Conf. Power Energy*, Kota Kinabalu, Malaysia, Dec. 2–5, 2012, pp. 605–610.
- [2] M. R. Islam, Y. G. Guo, and J. G. Zhu, "A medium-frequency transformer with multiple secondary windings for grid connection through H-bridge voltage source converters," in *Proc. Int. Conf. Electr. Mach. Syst.*, Sapporo, Japan, Oct. 21–24, 2012, pp. 1–6.
- [3] H. Akagi, "Classification, terminology, and application of the modular multilevel cascaded converter (MMCC)," *IEEE Trans. Power Electron.*, vol. 26, no. 11, pp. 3119–3130, Nov. 2011.
- [4] B. Gultekin and M. Ermis, "Cascaded multilevel converter-based transmission STATCOM: System design methodology and development of a 12 kV \pm 12 MVar power stage," *IEEE Trans. Power Electron.*, vol. 28, no. 11, pp. 4930–4936, Nov. 2013.
- [5] M. Hagiwara, K. Nishimura, and H. Akagi, "A medium-voltage motor drive with a modular multilevel PWM inverter," *IEEE Trans. Power Electron.*, vol. 25, no. 6, pp. 1786–1799, Jul. 2010.
- [6] M. R. Islam, Y. G. Guo, and J. G. Zhu, "Performance and cost comparison of NPC, FC and SCHB multilevel converter topologies for high-voltage applications," in *Proc. Int. Conf. Electr. Mach. Syst.*, Beijing, China, Aug. 20–23, 2011, pp. 1–6.
- [7] A. Luo, S. Peng, C. Wu, J. Wu, and Z. Shuai, "Power electronic hybrid system for load balancing compensation and frequency-selective harmonic suppression," *IEEE Trans. Ind. Electron.*, vol. 59, no. 2, pp. 723–732, Feb. 2012.

- [8] Q.-N. Trinh and H.-H. Lee, "An advanced current control strategy for three-phase shunt active power filters," *IEEE Trans. Ind. Electron.*, vol. 60, no. 12, pp. 5400–5410, Dec. 2013.
- [9] Li Zhang, Kai Sun, Yan Xing and Mu Xing, "H6 Transformerless Full-Bridge PV Grid-Tied Inverters", *IEEE Transactions on Power Electronics*, Vol.29, No.3, pp. 1229-1238 March 2014
- [10] F. Deng and Z. Chen, "A control method for voltage balancing in modular multilevel converters," *IEEE Trans. Power Electron.*, vol. 29, no. 1, pp. 66–76, Jan. 2014.
- [11] T. Zhao, G. Wang, S. Bhattachaya, and Q. Huang, "Voltage and power balance control for a cascaded H-bridge converter-based solid state transformer," *IEEE Trans. Power Electron.*, vol. 28, no. 4, pp. 1523–1532, Apr. 2013.
- [12] D. Dujic, C. Zhao, A. Mester, J. K. Steinke, M. Weiss, S. L. Schmid, T. Chaudhuri, and P. Stefanutti, "Power electronic traction transformer low voltage prototype," *IEEE Trans. Power Electron.*, vol. 28, no. 12, pp. 5522–5534, Dec. 2013.
- [13] B. Yang, W. Li, Y. Gu, W. Cui, and X. He, "Improved transformerless inverter with common-mode leakage current elimination for a photovoltaic grid-connected power system," *IEEE Trans. Power Electron.*, vol. 27, no. 2, pp. 752–762, Feb. 2012.
- [14] M. R. Islam, Y. G. Guo, J. G. Zhu, and D. Dorrell, "Design and comparison of 11 kV multilevel voltage source converters for local grid based renewable energy systems," in *Proc. 37th Annu. Conf. IEEE Ind. Electron. Soc.*, Melbourne, Australia, Nov. 7–10, 2011, pp. 3596–3601.
- [15] Z. Li, P. Wang, H. Zhu, Z. Chu, and Y. Li, "An improved pulse width modulation method for chopper-cell-based modular multilevel converters," *IEEE Trans. Power Electron.*, vol. 27, no. 8, pp. 3472–3481, Aug. 2012.
- [16] H. Xiao and S. Xie, "Transformerless split-inductor neutral point clamped three-level PV grid-connected inverter," *IEEE Trans. Power Electron.*, vol. 27, no. 4, pp. 1799–1808, Apr. 2012.
- [17] D. Dujic, C. Zhao, A. Mester, J. K. Steinke, M. Weiss, S. L. Schmid, T. Chaudhuri, and P. Stefanutti, "Power electronic traction transformer low voltage prototype," *IEEE Trans. Power Electron.*, vol. 28, no. 12, pp. 5522–5534, Dec. 2013.
- [18] F. Deng and Z. Chen, "A new structure based on cascaded multilevel converter for variable speed wind turbine," in *Proc. 36th Annu. Conf. IEEE Ind. Electron. Soc.*, AZ, USA, Nov. 2010, pp. 3167–3172.