



E-Health Monitoring System for Rural Sector

Neha P. Ali & Himani S. Bhosale

Department of Electronics And Telecommunication Engineering

ABSTRACT

Now a days people from rural areas are facing the health issues and Health Care is difficult task to maintain for them. In most of the rural areas Doctors are not available and people are unable to come in the cities. So we are trying to address these issues in rural sector in our project.

This project presents a simple health monitoring system which is well applicable for rural areas or in any Government institution. The system provides a good opportunity to gather and store health information about one or more observed patients. We are planning to design a reliable and accurate patient monitoring system for rural sector which can measure the parameters like body temperature, Blood Pressure, heartbeat and breathing. It is able to send parameters of patient in real time. This project provides a solution for enhancing the reliability and flexibility by improving the performance and accurate measurement of above parameters of the patient and treat the initial illness.

1. INTRODUCTION

Nowadays, the health monitoring in rural sector is an outstanding research area. Throughout the world lots of researchers and health institutions deal with health monitoring. The collected information sets about a patient helps the doctors in the examination of health state changes. Currently, there are many health monitoring devices and applications (e.g. intelligent watches and mobile applications) but most of those devices are expensive and difficult to acquire. Our goal is to develop a generally applicable network monitoring system and accurate monitoring system which is available for rural areas.

Actually, the system includes microcontroller based arduino nano board and programmable software. This system is

simple, small, accurate and portable. This system is responsible for sensor control and data transmission. This is useful when users or patients want to test their health issue or when the doctors want to check health problem. This system supports two data acquisition possibility, the first is the regular data acquisition. In this case, data collection happens at adjustable periods. In the second case a Java based program handles the incoming information and stores it in a MySQL or dot.net database. Our main goal in this project is to treat initial illness of the people and reduce the work done.



2. BLOCK DIAGRAM

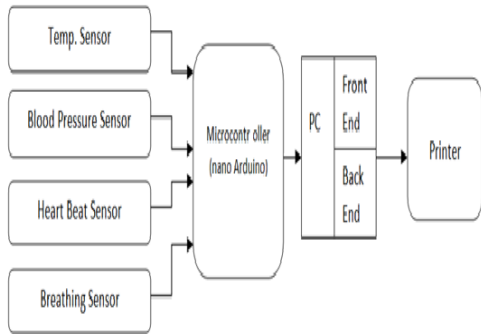

FIG 1: Block Diagram for e-Health Monitoring System

2.1. DESCRIPTION

2.1.1 Blood Pressure / Heart Rate Sensor - Display + Analog out

Blood Pressure & Pulse reading are shown in below figure. It give analog output for external projects of embedded processing circuit and display. It shows Systolic, Diastolic and Pulse Readings on display. This sensor contains compact design fits over your wrist like a watch. It is easy to use wrist style and it eliminates pumping.



FIG 2: Diagram for Blood Pressure sensors

Features :-

- Intelligent automatic compression and decompression
- Easy to operate, switching button to start measuring
- 60 store groups memory measurements
- Can read single or all measures
- 3 minutes automatic power saving device
- Intelligent device debugging, automatic power to detect
- Local tests for : wrist circumference as 135-195mm
- Large-scale digital liquid crystal display screen, Easy to Read Display
- Fully Automatic, Clinical Accuracy, High-accuracy
- Power by 2 x 1.5V AAA batteries (NOT included)
- Analog output voltage for external circuit processing or display.

2.1.2.

Digital Temperature Sensor Probe, Water proof, DS18B20

It

based on reliable temperature sensor chip D S18B20 with cable length of 1 meter.



FIG 3: Diagram for Temperature sensors

This is a pre-wired and waterproofed version of the DS18B20 sensor. Handy for when you need to measure something far away, or in wet conditions. While the sensor is good up to 125°C the cables jacketed in PVC so we suggest keeping it under 100°C. Because they are digital, you don't get any signal degradation even over long distances. These 1-wire digital

Temperature sensors are fairly precise ($\pm 0.5^\circ\text{C}$ over much of the range) and can give up to 12 bits of precision from the onboard Digital-to-analog converter.

They work

Greatly with any microcontroller using a single digital pin, and you can even connect multiple ones to the same pin, each one has a unique 64-bit ID burned in at the factory to differentiate them. Usable with 3.0-5.0V systems. The only downside is they use the Dallas 1-Wire protocol, which is somewhat complex, and requires a bunch of code to parse out the communication. When using with microcontroller put a 4.7k resistor to sensing pin, which is required as a pullup from the DATA to VCC line.

Cable specification:-

- Stainless steel tube 6mm diameter by 30mm long
- Cable is 36" long / 91cm, 4mm diameter (1 Meter Long)
- Contains DS18B20 temperature sensor
- Three wires - Red connects to 3-5V, Black connects to ground & White is data

DS18B20 Sensor Technical specs:-

- Usable temperature range: -55 to 125°C (-67°F to $+257^\circ\text{F}$)
- 9 to 12 bit selectable resolution
- Uses 1-Wire interface- requires only one digital pin for communication
- Unique 64 bit ID burned into chip
- Multiple sensors can share one pin
- $\pm 0.5^\circ\text{C}$ Accuracy from -10°C to $+85^\circ\text{C}$ Temperature limit alarm system
- Query time is less than 750ms
- Usable with 3.0V to 5.5V power/data

2.1.3. Heartbeat Pulse Sensor

This sensor attaches to finger and get Analog output from the sensor based on heart beat pulse.



FIG 4: Diagram for Heartbeat Pulse sensors

You can read the analog output with microcontroller ADC and then plot it or

- Bio-Feedback control of robotics and applications

calculate readings like heart beat per minute. It is simple to use and accurate results. This analog output can be connected to microcontroller with ADC pin directly to measure the Beats Per Minute (BPM) rate. It works on the principle of light modulation by blood flow through finger at each pulse. Applications:-

- Digital Heart Rate monitor
- Patient Monitoring System

Table1. Specification Parameter of Heart Beat Sensor

Sr. No.	Parameter	Value
1	Operating Voltage	+5V DC regulated
2	Operating Current	100 mA
3	Output Data Level	5V TTL level
4	Heart Beat detection	Analog Out
5	Detector	Photo diode

Board has 3-pin connector for using the sensor -

1. +5V Power supply Positive input
2. .A.OUT Analog voltage out (0-5V range)
3. GND Power supply Ground Using

Working:-

This sensor consists of a super bright red LED and light detector. The LED needs to be super bright as the maximum light must pass spread in finger and detected by detector. Now, when the heart pumps a pulse of blood through the blood vessels, the finger becomes slightly more opaque and so less light reached the detector. With each heart pulse the detector signal varies, this variation is converted to electrical pulse. This signal is amplified through an amplifier which outputs analog voltage between 0 to and 5V logic level signal.



2.2. ARDUINO NANO

Arduino is an open source gadgets prototyping stage in view of adaptable, simple to-utilize equipment and programming. It give stage to Artists, creators, specialists and anybody keen on making intuitive articles or environment. It's an open-source physical processing stage in view of a microcontroller board and an improvement situation for composing programming for the board. In straightforward words Arduino is a little microcontroller board with a USB fitting to interface with your PC and various association attachment that can be wired up to outer which are engine, hand-off, light, receivers, and so forth. They can either be controlled through the USB association from the PC or from a 9V battery Anyone can purchase this gadget through online closeout website or web index. Subsequent to the arduino is an open-source equipment outlines and make their own particular clones of the Arduino and offer them, so the business sector for the sheets is focused .An authority Arduino costs about \$30 and a clone regularly under \$20.



FIG 5: Diagram for Arduino nano Board

Open-source equipment shares a significant part of the standards and methodology of free and open-source programming. The

organizers of Arduino needed individuals to concentrate on their equipment to see how it functions roll out improvements to it, and offer those progressions with the world. The arduino programming is likewise open-source. The source code for the Java environment is discharged under the GPL and the C/C++ microcontroller libraries are under the LGPL.

Features:-

- Work with a Mac (as most design students use one)
- USB connectivity (Mac Books don't have serial ports)
- Look nice
- Cheap (about 20 euro's, the cost of going out for pizza in Europe)
- More powerful than a BASIC stamp
- Something you could build/fix yourself

Simple and easy to use by someone without formal electronics training

Language References:-

The Microcontroller on the board is customized utilizing the Arduino programming dialect (in light of wiring) and the Arduino improvement environment (taking into account preparing).

Software:-

This Arduino IDE is a cross-stage application written in Java, and is gotten from the IDE for the Processing programming dialect and the Wiring venture. It is intended to acquaint programming with specialists and different newcomers new to programming improvement. It incorporates a code manager with components, for example, grammar



highlighting, support coordinating, and programmed space, and is likewise fit for assembling and transferring projects to the board with a solitary snap. There is regularly no compelling reason to alter make documents or run programs on charge line interface. Despite the fact that expanding on summon line is conceivable if required with some outsider instruments, for example, Ino.The Arduino IDE accompanies a C/C++ library called "Wiring" (from the venture of the same name), which makes numerous basic data/yield operations much less demanding. Arduino projects are composed in C/C++, in spite of the fact that clients just need characterize two capacities to make a

runnable system:

Setup () – a capacity run once toward the begin of a system that can instate settings

Circle () – a capacity called over and over until the board power off.

Arduino projects can be partitioned in three fundamental parts: structure, values (variables and constants), and capacities Accessible information sorts in ARDUINO IDE are void and Boolean being the most essential among all. The Arduino dialect (taking into account Wiring) is actualized in C/C++, and accordingly has a few contrasts from the Processing dialect, which depends on Java.

3. CIRCUIT DIAGRAM

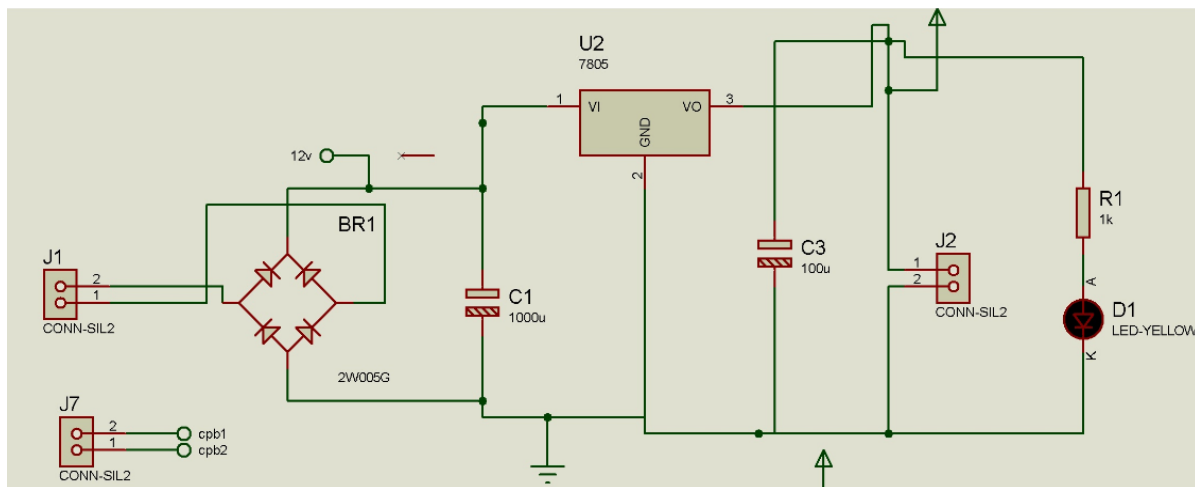

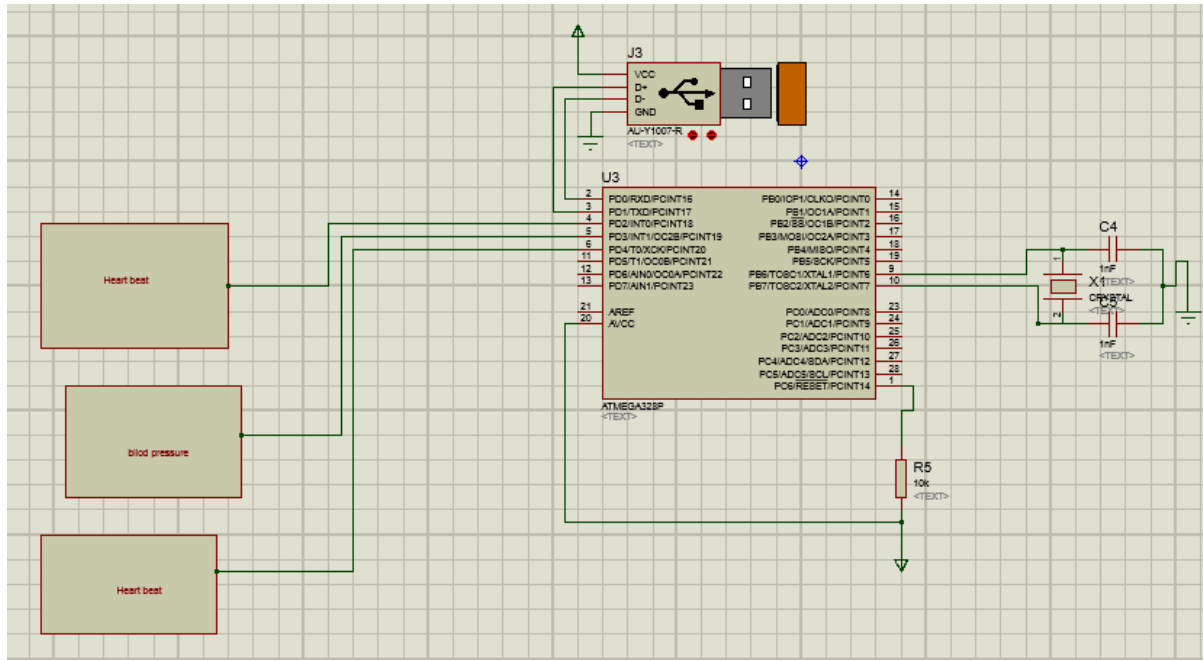

FIG 6: Circuit Diagram for e-Health Monitoring System

3.1. Hardware

As appeared in the above circuit outline Arduino, different kind of sensors and power supply is gone under equipment part which is clarify as takes after –

Arduino Circuit :- Various sort of sensors are associated with the Arduino computerized pins which is of D2-D4 through the wire and D0-D1 pins is joined with the D+ & D- of the USB link and resistor R5 is joined with the reset pin of the Arduino. This R5 is joined with the AVCC and makes reset circuit. XTAL1 & XTAL2 makes gem oscillator utilizing capacitor C4 & C5 which give swaying recurrence of 16 MHz We give the +5V supply to the Arduino Nano board and this supply is given to the diverse segments of the framework. The pc or PC is associated with the Arduino Nano board through USB. The other terminal of the USB i.e. VCC is joined with the force supply circuit and other terminal is ground. The using so as to peruse from the sensors has been taken Arduino then it goes to the separate framework which shows the general data identified with the wellbeing utilizing programming.

Control Supply: - Power supply having intersection J1 through which supply has given to extension rectifier. Rectifier is then associated capacitor C1 and voltage controller 7805 for venturing down voltage to 5V. In this swell has kept away from and lower voltage happened. For dodging swell further one more capacitor C2 has been utilized. One LED alongside resistor R1 has used to minimize the voltage at the info of LED. This is the finished working of force supply.



Along these lines we are utilizing control supply circuit for giving supply voltage to our separate framework.

3.2. Software

In this system we are design a software for PC in which we are storing patients details and related health parameter. We are design this software using Dot Net or SQL (Sequential Query Language) or PHP. This software is divided into two parts i.e. Front End and Back End.

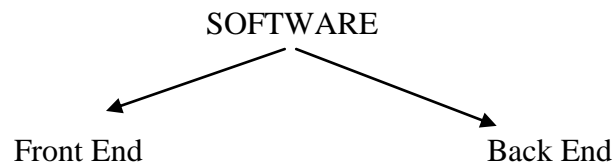

Front end contains the simple form in which we register the patients detail and three commands are given at the bottom such as 'Print, Recall & Submit'. If we click on Print command then printout will be taken from the Printer. If we select Recall then all the details about patients will be displayed and Submit command is used for submit the patient's details.

Back end used for storing patients details and for viewing measured health parameter. If anyone wants to see previous information then that information is stored in Back end. In this manner this software is very useful for our system and it makes system effective.

4. ADVANTAGES & APPLICATIONS

Advantages:-

- Easy and Reliable for rural people: In a rural sector, either the people or the doctor has to move physically from one area to another for health check, which may not be possible to monitor patient's health conditions continuously. Thus any critical situations cannot be found easily unless the doctor checks the person's health at that moment. This may be a strain for the people who have to take care their health and of a lot number of people in the hospital.

- Increase efficiency: The number of doctors required for keeping a check on patients in hospitals can be reduced to a large extent.
- More Accurate: Chances of human error in checking different health parameters is also reduced, also the database can be updated time to time.
- This can be used in any hospitals and in anywhere.
- It is simple to handle and for monitor.

Applications:-

- This technique presents a system to upgrade existing health monitoring systems in the hospitals by providing



monitoring capability and a thus a better cure.

- This monitoring system provides long term monitoring capability useful for the rural areas and the hospitals and reduces their workload.
- Future work may include more number of sensors in a single system to provide flexibility.
- Used in any government institution and any hospitals.

5.CONCLUSION

In order the system to be usable in a hospital, rural areas and server should handle the highest layer (application) of TCP/IP model and sensors because the system has to pay attention to data protection. In this system, the physiological parameters such as Body temperature, heart rate, body impact and blood pressure level are monitored. In addition, some parameters of the system have not tested yet. In future the system will be extended with some new sensors and analysis methods. The presented system solves some essential tasks and provides versatile application possibilities.

REFERENCES

- [1] Purnima, Puneet Singh on” Zigbee and GSM Based Patient Health Monitoring System” 2014 International Conference on Electronics and Communication System (ICECS -2014).
- [2] J. Sütő, S.Oniga and I.Orha on “Microcontroller based health monitoring system” 2013 IEEE 19th International Symposium for Design and Technology in Electronic Packaging (SIITME).
- [3] Amruta Chopade and Prof. Nitin Raut on “Remote Patients Health Monitoring by Using

Zigbee Protocol” Chopade et al., International Journal of Advanced Research in Computer Science and Software Engineering , August - 2014, pp. 207-214

[4] K. Navya1, Dr. M. B. R. Murthy ”A Zigbee Based Patient Health Monitoring System” Sep-Oct 2013

[5] Nazhatul hafizah kamarudin yusnani yussoff habibah hashim” Two-Tier e-Health Monitoring System” 2015

[6] Iuliana chiuchisan, oana geman “Stefan cel Mare” An Approach of a Decision Support and Home Monitoring System for Patients with Neurological Disorders using Internet of Things Concepts” 2014

[7] Prof.Sankpal L.J, Shashikant Shivkar,Prathmesh Ghumade,Tawhid Contractor “Wireless Interactive System for Patient Healthcare Monitoring using Android Mobile” February 2014 Purnima , Puneet Singh” Zigbee and GSM Based Patient Health Monitoring System” 2014

[8] J. Sütő, S. Oniga I. Orha “Microcontroller based health monitoring system” 2013

[9] Amruta Chopade1, Prof. Nitin Raut “Remote Patient”s Health Monitoring by Using Zigbee Protocol”August 2014

[10] Purnima, Puneet Singh on” Zigbee and GSM Based Patient Health Monitoring System” 2014 International Conference on Electronics and Communication System (ICECS -2014).



[11] J. Sütő, S.Oniga and I.Orha on
“Microcontroller based health monitoring
system” 2013 IEEE 19th International
Symposium for Design and Technology in
Electronic Packaging (SIITME).

[12] Amruta Chopade and Prof. Nitin Raut
on “Remote Patients Health Monitoring by
Using Zigbee Protocol” Chopade et al.,
International Journal of Advanced Research
in Computer Science and Software
Engineering , August - 2014, pp. 207-214