



Wsn Based Smart Sensor and Actuator for Power Management in Intelligent Buildings

Miss. Pratima R.Namalwar

Miss. Swati Meshram

Mr. shashikant Thakare

Mr. Abhijit Gondane

Mr.Pratik Fulmali

Abstract

The design and development of a smart monitoring and controlling system for household electrical appliances in real time has been reported in this paper. The system principally monitors electrical parameters of household appliances such as voltage and current and subsequently calculates the power consumed. The novelty of this system is the implementation of the controlling mechanism of appliances in different ways. The developed system is a low-cost and flexible in operation and thus can save electricity expense of the consumers. The prototype has been extensively tested in real-life situations and experimental results are very encouraging.

KEYWORDS : Energy management; home automation; intelligent control system; wireless sensor network; Zig Bee.

INTRODUCTION

IT is foreseen that service and personal care wireless mechatronic systems will become more and more ubiquitous at home in the near future and will be very useful in assistive healthcare particularly for the elderly and disabled people. Wireless mechatronic systems consist of numerous spatially distributed sensors with limited data collection and processing capability to monitor the environmental situation. Wireless sensor networks (WSNs) have become increasingly important because of their ability to monitor and manage situational information for various intelligent services. Due to those advantages, WSNs has been applied in many fields, such as the military, industry, environmental monitoring, and healthcare.

The WSNs are increasingly being used in the home for energy controlling services. Regular household appliances are monitored and controlled by WSNs installed in the home. New technologies include cutting-edge advancements in information technology, sensors, metering, transmission, distribution, and electricity storage technology, as well as providing new information and flexibility to both consumers and providers of electricity. The ZigBee Alliance, wireless communication platform is presently examining Japan's new smart home wireless system implication by having a new initiative with Japan's Government that will evaluate use of the forthcoming ZigBee, Internet Proto-col (IP) specification, and the IEEE 802.15.4g standard to help Japan to create smart



homes that improve energy management and efficiency.

It is expected that 65 million households will equip with smart meters by 2015 in the United States, and it is a realistic estimate of the size of the home energy management market.

There are several proposals to interconnect various domestic appliances by wireless networks to monitor and control such as provided in. But the prototypes are verified using test bed scenarios. Also, smart meter systems like have been designed to specific usages particularly related to geographical usages and are limited to specific places. Different information and communication technologies integrating with smart meter devices have been proposed and tested at different flats in a residential area for optimal power utilization, but individual controlling of the devices are limited to specific houses.

There has been design and developments of smart meters predicting the usage of power consumption. However, a low-cost, flexible, and robust system to continuously monitor and control based on consumer requirements is at the early stages of development. In this study, we have designed and implemented a ZigBee-based intelligent home energy management and control service. We used the ZigBee (the IEEE 802.15.4 standard) technology for networking and communication, because it has low-power and low-cost characteristics, which enable it to be widely used in home and building environments.

The paper focuses on human-friendly technical solutions for monitoring and easy control of household appliances. The inhabitant's comfort will be increased and better assistance can be provided. This paper emphasizes the realization of monitoring and controlling of electrical appliances in many ways.

The developed system has the following distinct features.

- 1) Use of Triac with opto-isolated driver for controlling electrical appliances: Household appliances are controlled either remotely or automatically with the help of fabricated smart sensing unit consisting of triac –BT138.
- 2) No microprocessor/microcontroller: The design of smart sensing unit does not require a processing unit at the sensing end.
- 3) Flexibility in controlling the appliances: Depending on the user requirements, appliances can be monitored and controlled in different ways.

SYSTEM DESCRIPTION

The system has been designed for measurement of electrical parameters of household appliances. Important functions to the system are the ease of modeling, setup, and use. From the consumer point of view, electrical power consumption of various appliances in a house along with supply voltage and current is the key parameter. Fig. 1 shows the functional description of the developed system to monitor electrical parameters and control appliances based on the consumer requirements.

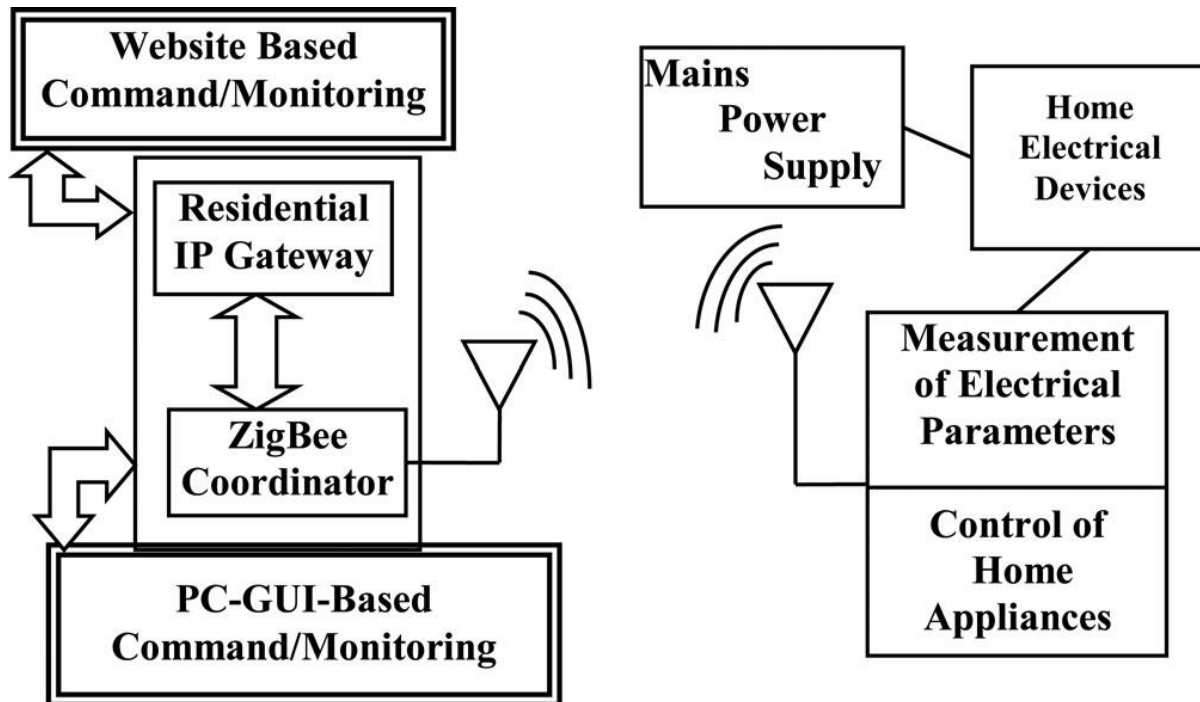

Fig. 1. Functional block diagram of the system

The measurement of electrical parameters of home appliances is done by interfacing with fabricated sensing modules. The details of the design and development of the sensing modules are provided in the following sections. The output signals from the sensors are integrated and connected to XBee module

for transmitting electrical parameters data wirelessly. The XBee modules are interfaced with various sensing devices and interconnected in the form of mesh topology to have reliable data reception at a centralized ZigBee coordinator. The maximum distance between the adjacent ZigBee nodes is less than 10 m, and through hopping technique of the mesh topology, reliable sensor fusion data has been performed.

The ZigBee coordinator has been connected through the USB cable of the host computer, which stores the data into a database of computer system. The collected sensor fusion data have been sent to an internet residential gateway for remote monitoring and controlling the home environment. By analyzing the power from the system, energy consumption can be controlled. An electricity tariff plan has been set up to run various appliances at peak and off-peak tariff rates. The appliances are controlled either automatically or manually (local/remotely). The smart power metering circuit is connected to mains 240 V/50 Hz supply.



Fig. 2 shows different appliances connected to the developed smart sensing system.

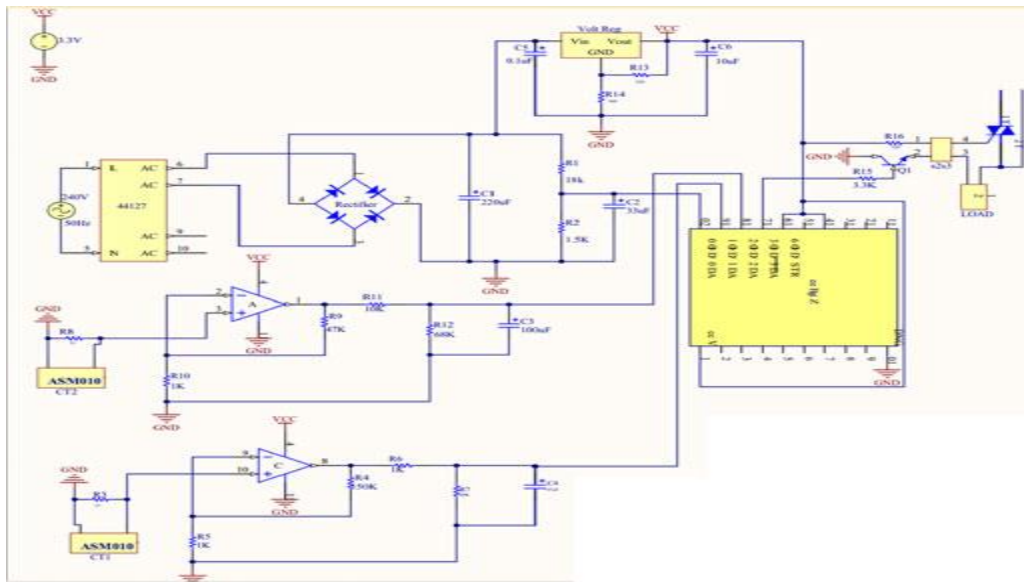

(a)

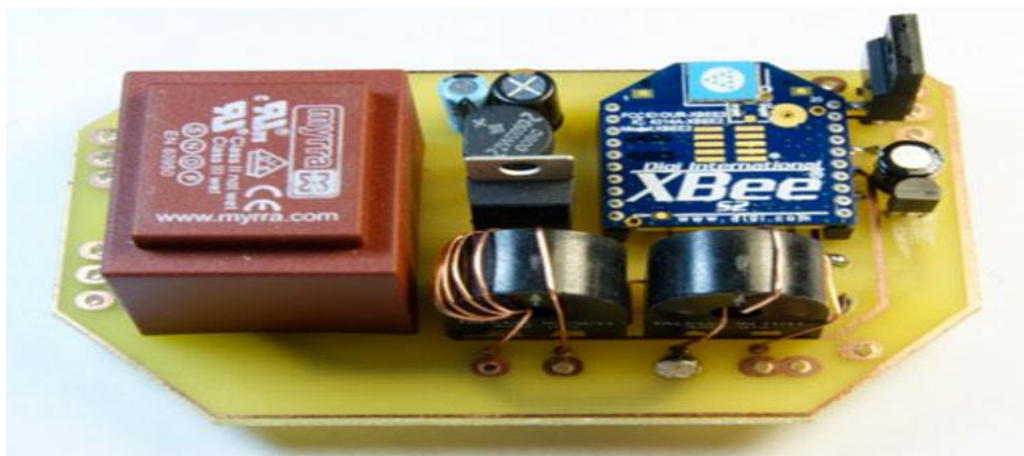

(b)

Fig. 3(a) and(b) shows the fabricated smart sensing measurement system.



A. Measurement Of Electrical Parameters

Voltage Measurement:

The voltage transformer used in our paper is the 44 127 voltage step-down transformer manufactured by MYRRA. The striking features include two bobbins compartments including self-extinguishing plastics and very light weight (100 g). The step-down voltage transformer is used to convert input supply of 230–240 V to 10 VRMS ac signal. The secondary voltage is rectified and passed through the filter capacitor to get a dc voltage. The details are shown in Fig. 3(a). The available dc voltage is reduced by a potential divider to bring it within the measured level of 3.3 V of the ZigBee. This output signal is then fed to analog input channel of ZigBee end device. The acquired voltage signal is directly proportional to the input supply voltage. A voltage regulator is connected to the rectified output of voltage transformer to obtain the precise voltage supply of 3.3 V for the operation of ZigBee and operational amplifier. The scaling of the signal is obtained from the input versus output voltage graph as shown in Fig. 4. The actual voltage is thus obtained as follows:

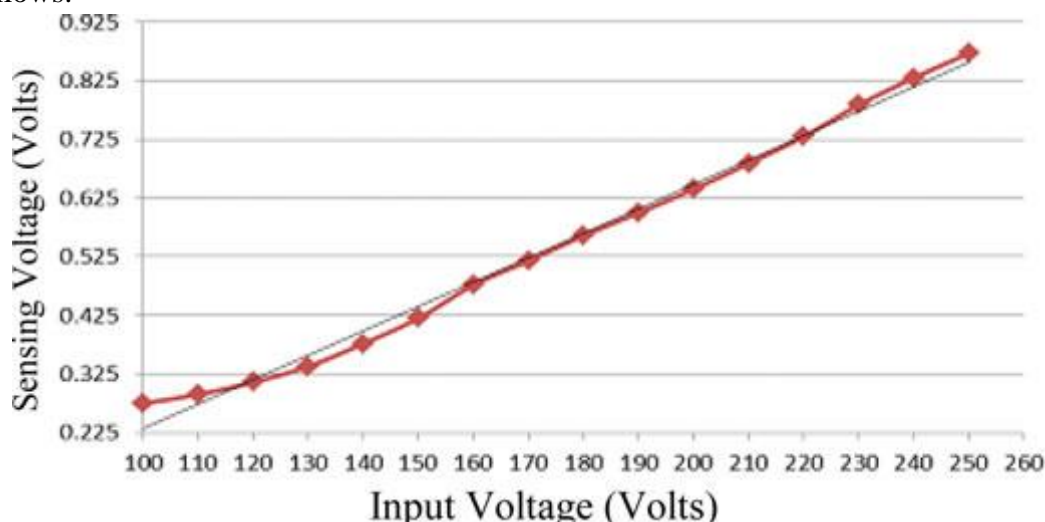

$$V_{act} = m1 \times V_{measured \text{ voltage}} \quad (1)$$

Where $m1$ is the scaling factor obtained from Fig. 4, V_{act} is the actual voltage, and $V_{measured \text{ voltage}}$ is the measured sensing voltage.

Current Measurement:

For sensing current, we used ASM010 current transformer manufactured by Talema. The main features of this sensor include fully encapsulated PCB mounting and compact size. The circuit design layout for current measurement is shown in Fig. 3(a). In this current sensor, the voltage is measured across the burden resistor of 50 Ω. The necessary filtering and



amplification is required to bring the voltage with the necessary measurement level of ZigBee. The scaling factors for current measurement for two different ranges of currents are shown in Fig. 5. Two different current transformers are used for two different ranges: 0–1 A and 1–10 A, respectively..

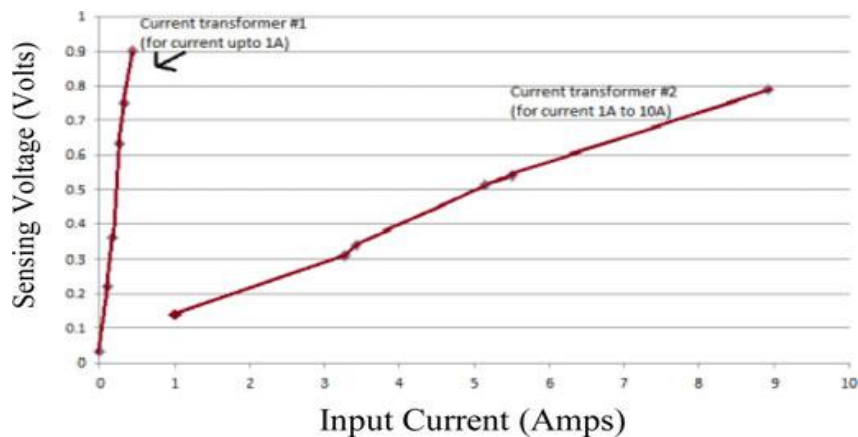

Fig. 5. Scaling factor (m_2) of current signal.

The actual current is thus obtained from (2). The line wire is connected to the load, which is passing through the current transformer. With the use of current transformer, the electrical isolation is achieved which is important in many applications as well as for the safety of the electronic circuit.

$$I_{act} = m_2 \times V_{measured} \text{ voltage for current (2)}$$

Where m_2 is the scaling factor obtained from Fig. 5, different values of m_2 to be used for different current transformers. I_{act} is the actual current; $V_{measured}$ voltage for current is the measured sensing voltage for current. The developed system includes two current transformers; one is used for the measurements of loads up to 100W and the other current transformer is used for the measurements of loads from 100 to 2000 W. The reason of providing two transformers is to provide two load outlets at the same sensing node. The number of turns is increased up to five turns to improve the resolution of the low current signal. Both outputs from the current transformers are fed to the analog input channels of ZigBee.

Power Measurement:

In order to calculate power of a single-phase ac circuit, the product of root mean square (RMS) voltage and RMS current must be multiplied by the power factor as given in (3). Power factor is the cosine of the phase angle of voltage and current waveforms as shown in the Fig. 6 for an ideal situation.

$$P_{act} = V_{rms} \times I_{rms} \times Pf \text{ (3)}$$



Where P_{act} is the actual power, V_{rms} and I_{rms} are the RMS values of voltage and current, respectively, and Pf is the power factor. The output signal of the current transformer completely depends on the nature of the connected

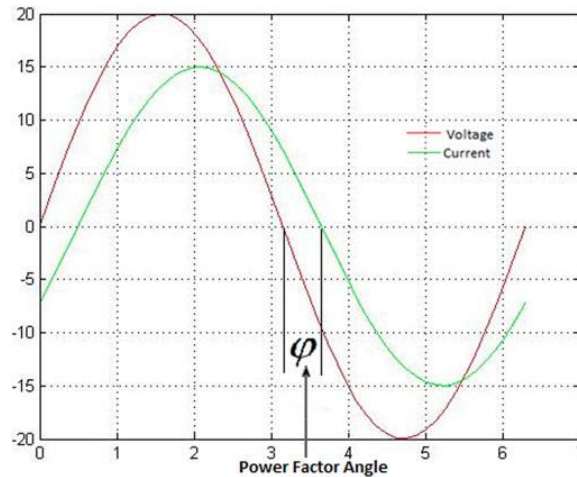
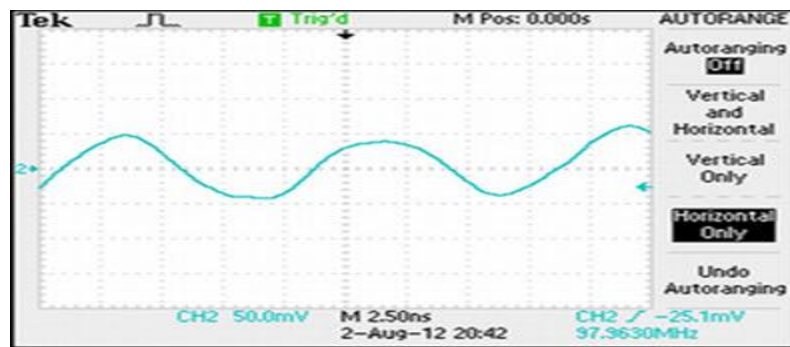
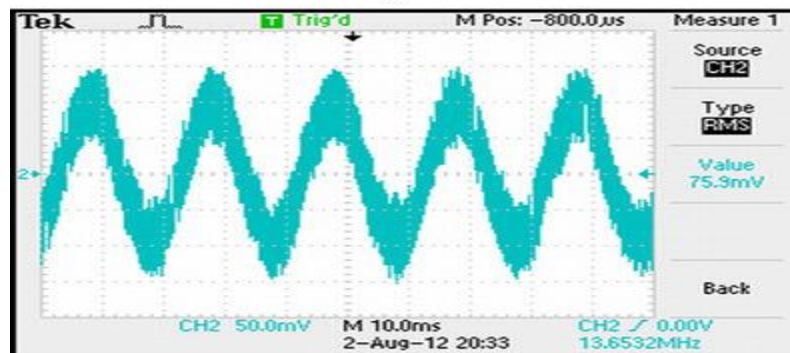

Fig. 6. Representation of power factor

appliances whether the connected load is purely resistive, capacitive, or inductive. In most of the domestic appliances, the output waveforms are not pure sinusoidal as shown in the following graphs Fig. 7(a)–(d) for different loading conditions. From the graphs, it is inferred that zero-crossing determination is difficult to measure for some of the appliances and elimination of noise is not trivial. Moreover, it is not important for this application to measure power with zero error. Hence, in our paper, instead of measuring power factor, we have introduced correction factor to normalize the received power with respect to the actual power based on the scaling factors of the voltage and current measured. The power consumed by the appliances is calculated in the computer system after receiving voltage outputs from corresponding current and voltage sensors by the following equation:



(a)



(b)



(c)

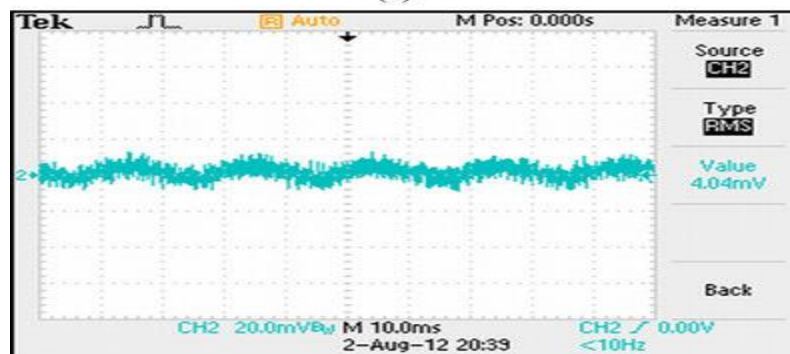

(d)

Fig. 7. Output waveform of current transformer for different appliances (a) Output waveform of current transformer for 100 W electric bulb, (b) output waveform of current transformer for 800W room heater, (c) output waveform of current transformer for 60 W electric bulb, and (d) output waveform of current transformer for audio device.



$$P_{cal} = V_{act} \times I_{act} \times C_f (4)$$

Where , P_{cal} is the calculated power; V_{act} the output voltage as given in (1); I_{act} the current value as given in (2); and C_f is the correction factor. The term correction factor is introduced to calculate power accurately by the system. The correction factor is the ratio of actual power to the measured power. Correction factor is required for the power measurement for some loads. This correction factor can be obtained by plotting graph for calculated power against the actual power. Thus, the power is calculated in computer using CSharp programming after receiving voltage outputs from corresponding current and voltage sensors. The prototype has been tested and results achieved for many household electrical appliances are shown in the following section.

Appliance	Ref. Load (W)	V ref (V)	I. Ref (amps)	Mea. Vol (V)	%Error-Voltage	Mea. Cur (amps)	%Error-Current	Cal. Power (W)	%Error-Power
Bulb	25	229	0.11	229	0	0.11	0.00	25.19	0.76
Bulb	39	229	0.16	230	0.22	0.17	4.25	38.1	4.61
Bulb	59	229	0.26	229	0	0.27	3.85	61.83	4.80
Bulb	73	229	0.32	229	0	0.32	0.00	73.28	0.38
Bulb	98	228	0.43	229	0.44	0.42	2.33	96.18	1.86
Heater	401	226	1.73	225	0.44	1.82	5.20	409.5	2.12
Heater	755	223	3.41	222	0.44	3.45	5.86	781.91	3.56
Heater	1155	224	5.15	223	0.44	5.16	6.43	1145.23	0.85
Toaster	811	226	3.49	226	0	3.56	1.17	808.97	0.25
Toaster	665	234	2.90	235	0.43	2.73	2.01	658.72	0.94
Heater	733	236	3.11	237	0.42	2.91	0.19	703.1	4.08
Heater	1217	235	5.19	236	0.43	5.05	2.70	1192	2.05
Heater	1902	233	8.17	234	0.43	7.83	4.16	1869	1.74
Kettle	1995	233	8.72	233	0	8.18	6.20	1917.2	3.90

Table I shows the percentage error for all measured parameters with the corresponding references.

It is seen that the maximum error is less than 5% for the domestic appliances. From the low percentage error of power, it has been decided that power can be calculated without considering power factor.

Control of Home Appliances

The current paper is novel in terms of other reported literature due to its control features.

Smart Power Metering System integrated With Traic:

For switching on/off of the electrical appliances, we have used a triac-BT138. This enables the consumer for flexibility in controlling the devices: The users (inhabitants) have the options of switching the device on/off in three different ways.

Automatic control:



Based on the electricity tariff conditions, the appliance can be regulated with the help of smart software. This enables the user to have more cost saving by auto switch off the appliances during the electricity peak hours. The electricity tariff is procured from the website of the electricity supply company and is updated at regular intervals.

Manual control:

An on/off switch is provided to directly intervene with the device. This feature enables the user to have more flexibility by having manual control on the appliance usage without following automatic control. Also, with the help of the software developed for monitoring and controlling user interface, user can control the device for its appropriate use. This feature has the higher priority to bypass the automatic control.

Remote control:

The smart power monitoring and controlling software system has the feature of interacting with the appliances remotely through internet (website). This enables user to have flexible control mechanism remotely through a secured internet web connection. This sometimes is a huge help to the user who has the habit of keeping the appliances ON while away from house. The user can monitor the condition of all appliances and do the needful. Thus, the user has the flexibility in controlling the electrical appliances through the developed prototype. **Residential IP Gateway: Transmission Over IP**

In order to transmit real-time sensed data over the internet from the collected computer system, the ZigBee packet information is to be transformed to the Internet Protocol Version 6 (IPv6). The key element in the data transformation from Zig- Bee packet is the address translation. This was implemented at the application gateway, a program for determining the source or destination address of a packet that encapsulates a ZigBee packets' payload. The corresponding application gateway program performs the address transformation mechanism for ZigBee to address non-ZigBee nodes. ZigBee is based upon the IEEE 802.14.5 protocol, which uses a 64-bit address for each node on a personal area network (PAN) and 16 bits to identify the PAN ID.

IPv6 uses 128 bits to address a node on the network, of which 48 bits represent the network, 16 bits represent the local network (PAN ID), and 64 bits represent the host id (sensor node). Therefore, the node address for the IEEE 802.15.4 can be placed in an IPv6 address, and the PAN ID can be used to identify the ZigBee network in an IPv6 address.



Addressing

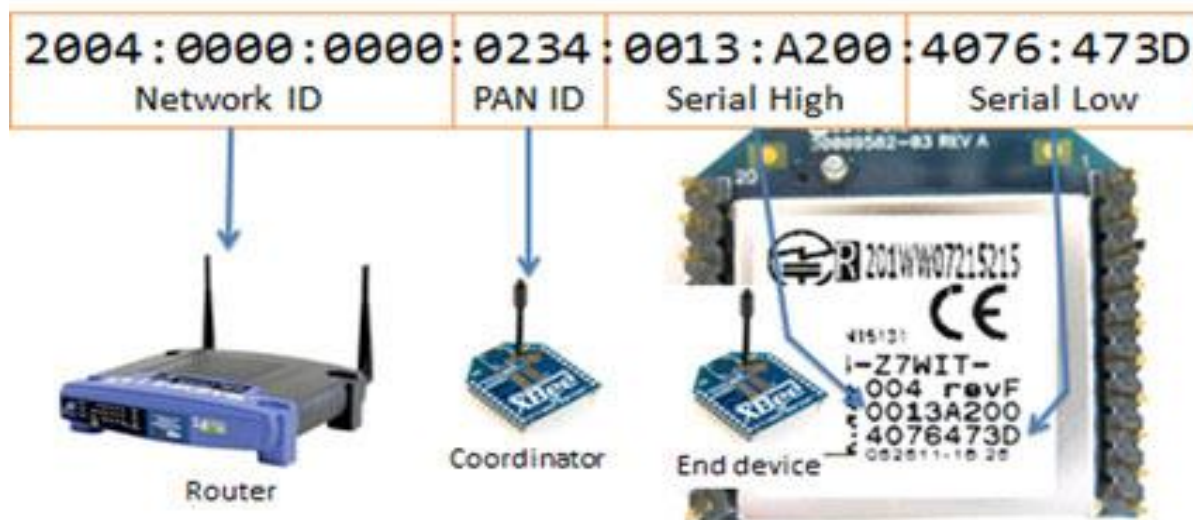

Fig. 8. Address transformation from ZigBee sensing unit to Internet packet.

The software used on the internet gateway to transmit data globally is the Linux-Open WRT [25]. This is basically router firmware software providing the networking architecture to participate in many types of internetworks. In order to remotely monitor and control the household appliances the residential internet gateway uses the Openwrt software to link to the internetworking protocol. These networks are embedded into internet routers and gateways for broadcasting data globally. The sensed data is forwarded through a tunneling and tapping (tun/tap) device driver software. The tun/tap acts as virtual network device software for bridging and routing functionalities (layer 2 and layer 3) of Internet Protocol (IPv6).

Storage of Data

The ZigBee packets produced at the gateway encapsulate sample data to be sent to windows based internet server. An application on the server receives packets on an arbitrary port and stores the relevant information in the background of MySQL

database in the computer. The database table store information such as source address, time, source channel, and sense data. Rows are added to this table for each packet received. This allows samples to be sorted by time, sensor node, and sensor channel.

In the present system, programs for address, packet transformations, and data transmission are written using "C" programming language, programs for packet reception and data storage are written using "C#," and Web interface is developed using PHP Script and Java Scripts.

LIMITATIONS AND FUTURE DEVELOPMENTS

A smart power monitoring and control system has been designed and developed toward the implementation of an intelligent building. The developed system effectively monitors and controls the electrical appliance usages at an elderly home.



Thus, the real-time monitoring of the electrical appliances can be viewed through a website. The system can be extended for monitoring the whole intelligent building. We aim to determine the areas of daily peak hours of electricity usage levels and come with a solution by which we can lower the consumption and enhance better utilization of already limited resources during peak hours. The sensor networks are programmed with various user interfaces suitable for users of varying ability and for expert users such that the system can be maintained easily and interacted with very simply. This study also aims to assess consumer's response toward perceptions of smart grid technologies, their advantages and disadvantages, possible concerns, and overall perceived utility.

CONCLUSION

The developed system is robust and flexible in operation. For the last three months, the system was able to perform the remote monitoring and control of appliances effectively. Local and remote user interfaces are easy to handle by a novice consumer and are efficient in handling the operations.