



Speed Control of BLDC Motor using Pulse width Modulation

B. M. Khangarale; B.J. Charde; P.B Thakre & T.L. Bonde

Dr. Babasaheb Ambedkar College Of Engineering & Research Department of Electrical
Engineering
trupti_bonde@yahoo.com

Abstract -

Brushless dc electric motor also known as electronic commutated motor are synchronous motors that are powered by a dc electric source via and integrated inverter / switching power supply, which produces an ac electric signal to drive the motor. In this context, Ac, alternating current does not employ a sinusoidal waveform, but rather a bidirectional current with no restriction on waveform.

IJ INTRODUCTION

Introduction to Speed Control BLDC Motor

The speed control of BLDC motors is very essential. The present system speed control is not very effective. This proposed system provides a very precise and effective control system. The user can enter the desired speed (predefined speed) which is stored in an EEPROM and the motor will run at that speed. If the power supply is off, the EEPROM retains the last speed entered. When the supply is resumed, the motor will run at the last entered speed.

Based on the principle of PWM speed can be controlled. This is achieved by keeping BLDC motor on closed loop feedback and giving RPM reference of the motor by a shaft mounted IR sensing arrangement which is fed to the microcontroller in the circuit. A display unit displays the full speed and one can enter the desired percentage with help of switches to vary the speed. The pulse width would be automatically adjusted to maintain the DC power to the motor such that the entered speed percentage matches the present RPM. The above operation is carried out by using one opto-isolator and a MOSFET for driving the BLDC motor and IR sensing is used for getting the speed reference to the microcontroller.

An EEPROM is interfaced to the microcontroller. EEPROM being a non volatile memory stores the speed reference to feed to the control circuit that forces the motor to always run at the same speed. Two switches are used as input to the MC for increasing or decreasing the speed of the BLDC motor.

Here are the advantages of BLDC Motor

1. Advantages of a BLDC motors is that it can be made smaller and lighter than a brush type with the same power output, making the former suitable for applications where space is tight.
2. BLDC motor provide the advantages of brushed Dc motor in terms of variable speed operation without drawback of brushes.

a) BRUSHLESS DC MOTOR

The term "Brushless DC motor" is used to identify the combination of ac machine, Solid-state inverter, and rotor position, sensor that result in drive system having a linear torque-speed characteristics, as in conventional dc mechanical. Brushless DC motor are one of electrical drive that are rapidly gaining popularity, due to their high efficiency, good dynamic response and low maintenance.

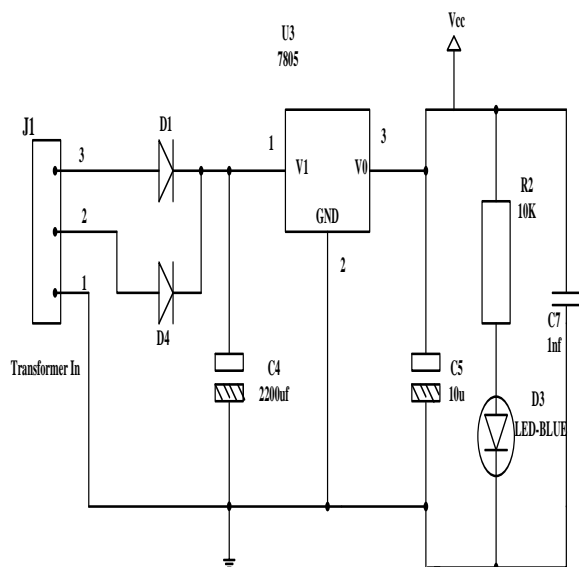

Fig1: Power Diagram

II] METHODOLOGY

a) OPERATING PRINCIPLE

This project attempts a new speed control technique for single phase brushless DC motor . It has low cost, high efficiency drive capable of supplying a single phase BLDC motor with PWM technique. The circuit operation control by an 8051 family microcontroller.

b) BLOCK DIAGRAM

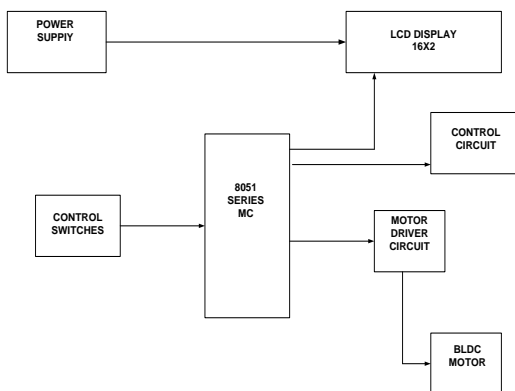

Fig2: Block Diagram of speed control of BLDC motor using PWM technique

c) HARDWARE SYSTEM

1) TRANSFORMER

Transformer is a device that transfer electrical energy from one circuit to another through another inductively couple conductors- the transformer’s coils. A varying current in the first or primary winding creates a varying flux in the transformer’s core, and thus varying magnetic field through secondary winding.

BASIC PRINCIPLE

The transformer is based on two principle “firstly, that an electric current that produce a magnetic field and secondly that changing magnetic field within a coil of a wire induces a voltage across the end of the coil.

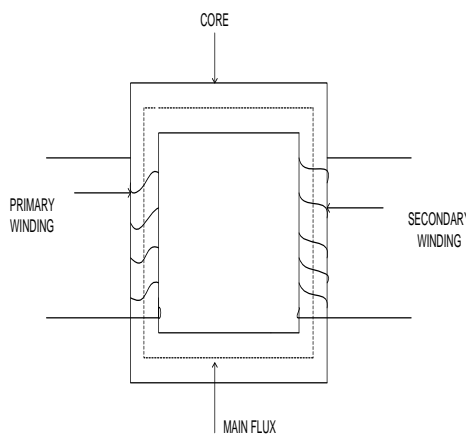

Fig 3: Single Phase Transformer

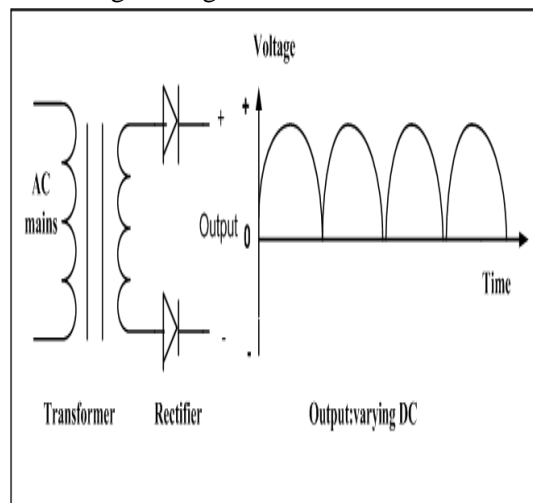

Fig 4: Showing transformer rectifier circuit and output waveform

2) RECTIFIER



Rectifier used to rectify the negative half cycle of the output signal of secondary of the transformer so at the input of the rectifier we have AC signal with both positive and negative cycles and at the output of rectifier we have signal with only positive cycle but as this signal is also AC we have to use capacitor to filter out the AC of the output signal. There are mainly three types of rectifier namely: Half wave, Full Wave and Bridge rectifier. Out of these three we have used full wave rectifier.

3) FILTER CAPACITOR

As mentioned above, we have to use filter capacitor to remove AC signal from the output of the rectifier. Filter capacitor is used in order to remove ripples from the pulsating DC and convert it to unregulated DC. A capacitor is an electrical device that can store energy in the electrical field between a pair of closely spaced conductors ('called plates').

When voltage is applied to the capacitor, electric charges of the magnitude, but opposite polarity, build up on the plate. Capacitors are used in electrical circuits as energy storage devices.

They can also be used to differentiate between high frequency and low frequency signals and this makes them useful in electronic filters.

4) REGULATOR

7805 is a voltage regulator integrated circuit. It is a member of 78xx series of fixed linear voltage ICs. The voltage source in a circuit may have a fluctuation and would not give the fixed voltage output. The voltage regulator IC maintains the output voltage at a constant value. The xx in 78xx indicates the fixed output voltage it is designed to provide. 7805 provides +5V regulated power supply.

III] CONCLUSION

In conclusion BLDC motor has advantages over Brushed DC motor and Induction motor. They have better speed versus torque characteristics, high dynamic response, high

efficiency, long operating life, noiseless operation, higher speed ranges, rugged construction and so on. Also the torque delivered to the motor size is higher, making it useful in applications where space and weight are critical factors.

IV] REFERENCES

- [1] H.W. Van Der Broeck and J. D. VanWyk, "A comparative investigation of a three-phase induction machine drive with a component minimized voltage-fed inverter under different control options," *IEEE Trans. Ind. Applicat.*, vol. 20, pp. 309–320, Mar./Apr. 1984.
- [2] F. Blaabjerg, D. O. Neacsu, and J. K. Pedersen, "Adaptive SVM to compensate dc-link voltage ripple for four-switch three-phase voltage source inverter," *IEEE Trans. Power Electron.*, vol. 14, pp. 743–752, July 1999.
- [3] G. T. Kim and T. A. Lipo, "VSI-PWM rectifier/inverter system with a reduced switch count," *IEEE Trans. Ind. Applicat.*, vol. 32, pp. 1331–1337, Nov./Dec. 1996.
- [4] J. I. Itoh and K. Fujita, "Novel unity power factor circuits using zero vector control for single-phase input systems," *IEEE Trans. Power Electron.*, vol. 15, pp. 36–43, Jan. 2000.
- [5] P. Pillay and P. Freere, "Literature survey of permanent magnet ac motors and drives," in *Proc. IEEE IAS Rec.*, 1989, pp. 74–84.
- [6] K. Iizuka, H. Uzuhashi, M. Kano, T. Endo, and K. Mohri, "Microcomputer control for sensorless brushless motor," *IEEE Trans. Ind. Appl.*, vol. IA-21, no. 4, pp. 595–601, Jul. 1985.
- [7] S. Ogasawara and H. Akagi, "An approach to position sensorless drive for brushless DC



motors,” *IEEE Trans. Ind. Appl.*, vol. 27, no. 5,
pp. 928–933, Sep. 1991.

without position sensors,” U.S. Patent 4 162
435, Jul. 24, 1979.

[8] F. H. Wright, “Method and apparatus for
electronically commutating a direct current motor