

Active Power Filter for Renewable Energy applications Using Predictive Control Scheme

Shaik.Shamsheer¹ & Dr. Akbar Khan²

¹M.Tech Scholar, Dept of EEE , Nimra Institute of Science and Technology, JNTUK, A.P

² Professor, Nimra Institute of Science and Technology, JNTUK, A.P

Abstract: — *In this paper an active power filter implemented with a four-leg voltage-source inverter using a predictive control scheme is presented. The use of a four-leg voltage source inverter allows the compensation of current harmonic components, as well as unbalanced current generated by single-phase nonlinear loads. A detailed yet simple mathematical model of the active power filter, including the effect of the equivalent power system impedance, is derived and used to design the predictive control algorithm. The compensation performance of the proposed active power filter and the associated control scheme under steady state and transient operating conditions is demonstrated through simulations results. In recent times, fuzzy logic controller was applied for active power filter (APF) control application, as the APF is nothing but a current controlled VSI. In this project, a fuzzy logic based shunt APF is presented based on the effective time concept. The effective time concept eliminates the trigonometric calculations and sector identification, thereby it reduces the computational effort. Simulation results demonstrate the efficacy of the APF with the fuzzy logic based control strategy. Simulation results are obtained for both predictive control scheme and fuzzy logic controller and the results are care compared. The response time for compensation is 0.02sec. Computer simulation by MATLAB/ SIMULINK has been used to support the developed concept.*

Keywords: Active power filter; current control; four-leg converters; predictive control; Fuzzy logic controller

I. INTRODUCTION

Electric utilities and end users of electric power are becoming increasingly concerned about meeting the growing energy demand. Seventy five percent of total global energy demand is supplied by the burning of fossil fuels. But increasing air pollution, global warming concerns, diminishing fossil fuels and their increasing cost have made it necessary to look towards renewable sources as a future energy solution. Since the past decade,

there has been an enormous interest in many countries on renewable energy for power generation. The market liberalization and government's incentives have further accelerated the renewable energy sector growth. Distributed generation (DG) systems are presented as a suitable form to offer high reliable electrical power supply [1]. The concept is particularly interesting when different kinds of energy. Resources are available, such as photo-voltaic panels, fuel cells, or speed wind turbines [2], [3]. Most part of these resources need power electronic interfaces to make up local ac grids [4], [5]. This way, inverters or ac-to-ac converters are connected to an ac common bus with the aim to share properly the disperse loads connected to the local grid [6]. Most sustainable energy sources supply energy in the form of electrical power. Distributed generation (DG) systems are often connected to the utility grid through power electronic converters. A grid connected inverter provides the necessary interface of the DG to the phase, frequency and amplitude of the grid voltage, and disconnects the system from the grid when islanding. Such a DG system can be designed to operate in both standalone and grid-connected modes flexibly according to Grid conditions [1], [2]. When the utility grid is not available or the utility power is accidentally lost, the DG is used as an on-site power or standby emergency power service, effectively being an extended uninterruptible power supply (UPS) that is capable of providing long-term energy supply.

The non-linear load current harmonics may result in voltage harmonics and can create a serious PQ problem in the power system network. Active power filters (APF) are extensively used to compensate the load current harmonics and load unbalance at distribution level. This results in an additional hardware cost. However, in this paper authors have incorporated. The features of APF in the, conventional inverter interfacing renewable with the grid, without any additional hardware cost.

This paper presents the mathematical model of the 4L-VSI and the principles of operation of the proposed predictive control scheme, including the design procedure. The complete description of the selected current reference generator implemented in the active

power filter is also presented. Finally, the proposed active power filter and the effectiveness of the associated control scheme compensation are demonstrated through simulation and validated with experimental results obtained in a 2 kVA laboratory prototype.

II. PROPOSED TOPOLOGY – FOUR LEG CONVERTER MODEL

The four-leg PWM converter topology is shown in Fig. 1. This converter topology is similar to the conventional three-phase converter with the fourth leg connected to the neutral bus of the system. The fourth leg increases switching states from 8 (23) to 16 (24), improving control flexibility and output voltage quality [11], and is suitable for current unbalanced compensation.

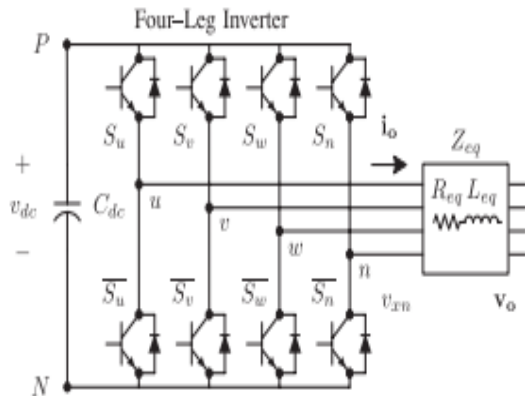

Fig. 1. Two-level four-leg PWM-VSI topology

III. PROPOSED TOPOLOGY – DIGITAL PREDICTIVE CURRENT CONTROL

The block diagram of the proposed digital predictive current control scheme is shown in Fig. 2. This control scheme is basically an optimization algorithm and, therefore, it has to be implemented in a microprocessor. Consequently, the analysis has to be developed using discrete mathematics in order to consider additional restrictions such as time delays and approximations [10], [11–12]. The main characteristic of predictive control is the use of the system model to predict the future behaviour of the variables to be controlled. The controller uses this information to select the optimum switching state that will be applied to the power converter, according to predefined optimization criteria. The predictive control algorithm is easy to

implement and to understand, and it can be implemented with three main blocks, as shown in Fig. 2.

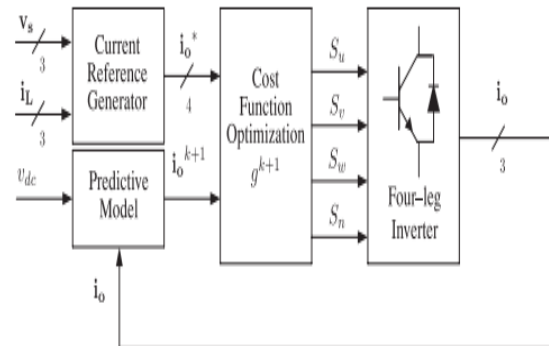

Fig. 2. Proposed predictive digital current control block diagram

IV. PROPOSED TOPOLOGY – CURRENT REFERENCE GENERATION

A dq -based current reference generator scheme is used to obtain the active power filter current reference signals. This scheme presents a fast and accurate signal tracking capability. This characteristic avoids voltage fluctuations that deteriorate the current reference signal affecting compensation performance [4]. The current reference signals are obtained from the corresponding load currents as shown in Fig. 3. This module calculates the reference signal currents required by the converter to compensate reactive power, current harmonic and current imbalance. The displacement power factor ($\sin \phi(L)$) and the maximum total harmonic distortion of the load ($\text{THD}(L)$) defines the relationships between the apparent power required by the active power filter, with respect to the load, as shown

$$\frac{S_{APF}}{S_L} = \frac{\sqrt{\sin^2 \phi(L) + \text{THD}(L)^2}}{\sqrt{1 + \text{THD}(L)^2}}$$

where the value of $\text{THD}(L)$ includes the maximum compensable harmonic current, defined as double the sampling frequency f_s . The frequency of the maximum current harmonic component that can be compensated is equal to one half of the converter switching frequency.

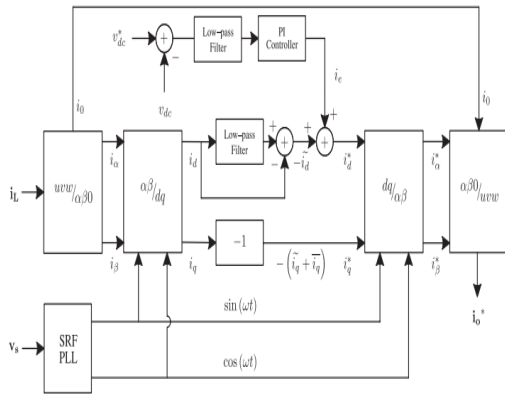

Fig.3. dq-based current reference generator block diagram.

The dq-based scheme operates in a rotating reference frame; therefore, the measured currents must be multiplied by the $\sin(\omega t)$ and $\cos(\omega t)$ signals. By using dq-transformation, the d current component is synchronized with the corresponding phase-to-neutral system voltage, and the q current component is phase-shifted by 90° . The $\sin(\omega t)$ and $\cos(\omega t)$ synchronized reference signals are obtained from a synchronous reference frame (SRF) PLL [9]. The SRF-PLL generates a pure sinusoidal waveform even when the system voltage is severely distorted. Tracking errors are eliminated, since SRF-PLLs are designed to avoid phase voltage unbalancing, harmonics (i.e., less than 5% and 3% in fifth and seventh, respectively), and offset caused by the nonlinear load conditions and measurement errors [13]. The bellow equation shows the relationship between the real currents $iLx(t)$ ($x = u, v, w$) and the associated dq components (id and iq)

$$\begin{bmatrix} i_d \\ i_q \end{bmatrix} = \sqrt{\frac{2}{3}} \begin{bmatrix} \sin \omega t & \cos \omega t \\ -\cos \omega t & \sin \omega t \end{bmatrix} \begin{bmatrix} 1 & -\frac{1}{2} & -\frac{1}{2} \\ 0 & \frac{\sqrt{3}}{2} & -\frac{\sqrt{3}}{2} \end{bmatrix} \begin{bmatrix} i_{Lu} \\ i_{Lv} \\ i_{Lw} \end{bmatrix}$$

A low-pass filter (LFP) extracts the dc component of the phase currents id to generate the harmonic reference components $-id$. The reactive reference components of the phase-currents are obtained by phase-shifting the corresponding ac and dc components of Iq by 180° . In order to keep the dc-voltage constant, the amplitude of the converter reference current must be modified by adding an active power reference signal ie with the d -component. The resulting signals $i*d$ and $i*q$ are transformed back to a three-phase system by applying the inverse Park and Clark transformation, as shown in bellow equation. The cutoff frequency of the LFP used in this paper is 20 Hz

The current that flows through the neutral of the load is compensated by injecting the same instantaneous value obtained from the phase-currents, phase-shifted by 180° , as shown next

$$\begin{bmatrix} i_{ou}^* \\ i_{ov}^* \\ i_{ow}^* \end{bmatrix} = \sqrt{\frac{2}{3}} \begin{bmatrix} \frac{1}{\sqrt{2}} & 1 & 0 \\ \frac{1}{\sqrt{2}} & -\frac{1}{2} & \frac{\sqrt{3}}{2} \\ \frac{1}{\sqrt{2}} & -\frac{1}{2} & -\frac{\sqrt{3}}{2} \end{bmatrix} \times \begin{bmatrix} 1 & 0 & 0 \\ 0 & \sin \omega t & -\cos \omega t \\ 0 & \cos \omega t & \sin \omega t \end{bmatrix} \begin{bmatrix} i_0 \\ i_d^* \\ i_q^* \end{bmatrix}$$

$$i_{on}^* = -(i_{Lu} + i_{Lv} + i_{Lw})$$

One of the major advantages of the dq-based current reference generator scheme is that it allows the implementation of a linear controller in the dc voltage control loop. However, one important disadvantage of the dq-based current reference frame algorithm used to generate the current reference is that a second order harmonic component is generated in id and iq under unbalanced operating conditions. The amplitude of this harmonic depends on the percent of unbalanced load current (expressed as the relationship between the negative sequence current $iL,2$ and the positive sequence current $iL,1$). The second-order harmonic cannot be removed from id and iq , and therefore generates a third harmonic in the reference current when it is converted back to abc frame [11]. Fig. 4. shows the percent of system current imbalance and the percent of third harmonic system current, in function of the percent of load current imbalance. Since the load current does not have a third harmonic, the one generated by the active power filter flows to the power system.

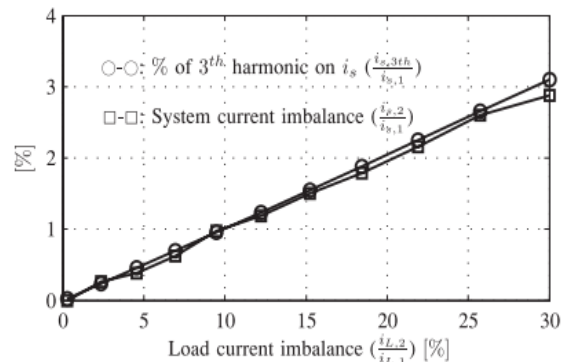

Fig. 4. Relationship between permissible unbalance load currents, the corresponding third-order harmonic content,

and system current imbalance (with respect to positive sequence of the system current, $i_s, 1$)

V. MATLAB BASED SIMULATION & RESULTS DISCUSSION

To verify the feasibility of the proposed system a simulink model is developed with modular converter which gives output. Fig.5 & Fig.6 shows the sub system in the developed simulink model

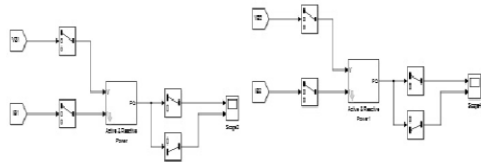
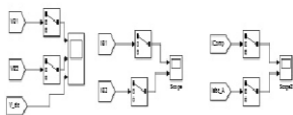

Fig.5. MATLAB based simulation diagram of proposed system with masked blocks

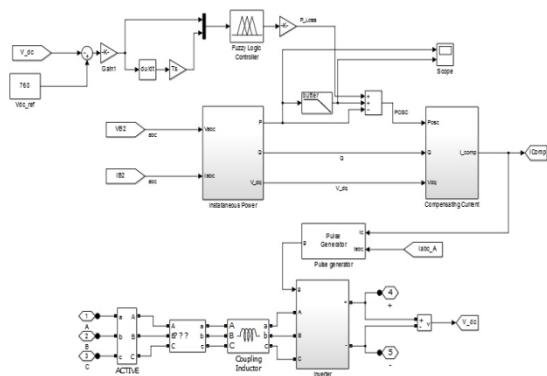

Fig.6. MATLAB based simulation diagram of proposed system with masked blocks

Fig.7. Shows the MATLAB based simulation of the proposed control scheme dc voltage

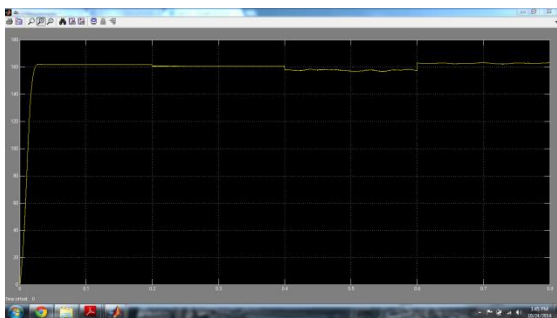

Fig.7. MATLAB based simulation of the proposed control scheme dc voltage

Fig.8. Shows the MATLAB based simulation of the proposed control scheme Load Current

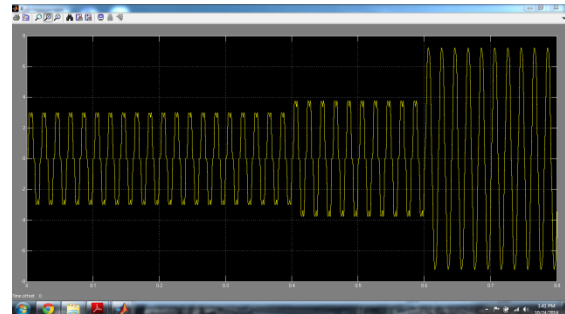

Fig.8. MATLAB based simulation of the proposed control scheme Load Current

Fig.9. Shows the MATLAB based simulation of the proposed control scheme - Active power filter neutral current

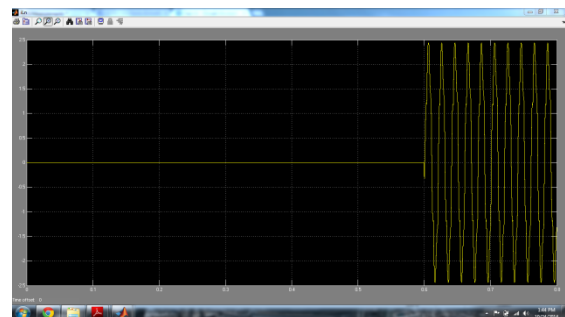

Fig.9. MATLAB based simulation of the proposed control scheme - Active power filter neutral current

Fig.10. Shows the MATLAB based simulation of the proposed control scheme - Isabc

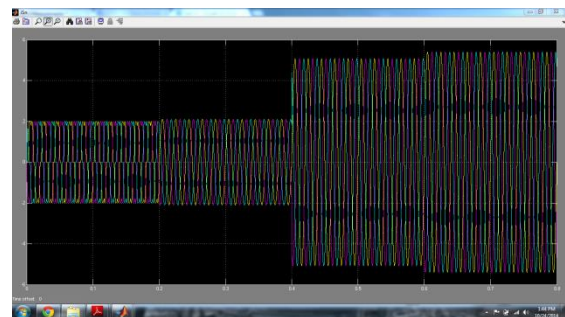

Fig.10. MATLAB based simulation of the proposed control scheme - Isabc

The compensation effectiveness of the active power filter is corroborated in a 2 kVA experimental setup. A six-pulse rectifier was selected as a nonlinear load in order to verify the effectiveness of the current harmonic compensation. A step load change was applied to evaluate the transient response of the dc voltage loop. Finally, an unbalanced load was used to validate the performance of the neutral current compensation. Because the experimental implementation was performed on a dSPACE I/O board, all I/O Simulink blocks used in the simulations are 100% compatible with the dSPACE system capabilities. The complete control loop is executed by the controller every 20 μ s, while the selected switching state is available at 16 μ s. An average switching frequency of 4.64 kHz is obtained.

Table.I shows the simulation parameters for the proposed system

TABLE.I.SIMULATION SPECIFICATIONS

Parameter	Rating
Source Voltage	55 V
Dc Voltage	162 V
Frequency	50Hz
DC Voltage	760
DC Link Capacitance	2200 μ F
Sampling Time	20 μ sec
	4 kW
Filter Inductance	5 mH

CONCLUSION

Improved dynamic current harmonics and a reactive power compensation scheme for power distribution systems with generation from renewable sources has been proposed to improve the current quality of the distribution system. Advantages of the proposed scheme are related to its simplicity, modeling, and implementation. The use of a predictive control algorithm for the converter current loop proved to be an effective solution for active power filter applications, improving current tracking capability, and transient response. Simulated and experimental results have proved that the proposed predictive control algorithm is a good alternative to classical linear control methods. The predictive current control algorithm is a stable and robust solution. Simulated and experimental results have shown the compensation effectiveness of the proposed active power filter.

REFERENCES

- [1] J. Rocabert, A. Luna, F. Blaabjerg, and P. Rodriguez, "Control of power converters in AC microgrids," *IEEE Trans. Power Electron.*, vol. 27, no. 11, pp. 4734–4749, Nov. 2012.
- [2] S. Naidu and D. Fernandes, "Dynamic voltage restorer based on a fourleg voltage source converter," *Gener. Transm. Distrib., IET*, vol. 3, no. 5, pp. 437–447, May 2009
- [3] N. Prabhakar and M. Mishra, "Dynamic hysteresis current control to minimize switching for three-phase four-leg VSI topology to compensate nonlinear load," *IEEE Trans. Power Electron.*, vol. 25, no. 8, pp. 1935– 1942, Aug. 2010.
- [4] V. Khadkikar, A. Chandra, and B. Singh, "Digital signal processor implementation and performance evaluation of split capacitor, four-leg and three h-bridge-based three-phase four-wire shunt active filters," *Power Electron., IET*, vol. 4, no. 4, pp. 463–470, Apr. 2011.
- [5] F. Wang, J. Duarte, and M. Hendrix, "Grid interfacing converter systems with enhanced voltage quality for microgrid application;concept and implementation," *IEEE Trans. Power Electron.*, vol. 26, no. 12, pp. 3501– 3513, Dec. 2011.
- [6] R. de Araujo Ribeiro, C. de Azevedo, and R. de Sousa, "A robust adaptive control strategy of active power filters for power-factor correction, harmonic compensation, and balancing of nonlinear loads," *IEEE Trans. Power Electron.*, vol. 27, no. 2, pp. 718–730, Feb. 2012.
- [7] X. Wei, "Study on digital pi control of current loop in active power filter," in *Proc. 2010 Int. Conf. Electr. Control Eng.*, Jun. 2010, pp. 4287–4290.
- [8] P. Cortes, G. Ortiz, J. Yuz, J. Rodriguez, S. Vazquez, and L. Franquelo, "Model predictive control of an inverter with output LC filter for UPS applications," *IEEE Trans. Ind. Electron.*, vol. 56, no. 6, pp. 1875–1883, Jun. 2009.
- [9] R. Vargas, P. Cortes, U. Ammann, J. Rodriguez, and J. Pontt, "Predictive control of a three-phase neutral-point-clamped inverter," *IEEE*

Trans. Ind. Electron., vol. 54, no. 5, pp. 2697–2705, Oct. 2007.

[10] P. Cortes, A. Wilson, S. Kouro, J. Rodriguez, and H. Abu-Rub, "Model predictive control of multilevel cascaded H-bridge inverters," *IEEE Trans. Ind. Electron.*, vol. 57, no. 8, pp. 2691–2699, Aug. 2010.

[11] P. Lezana, R. Aguilera, and D. Quevedo, "Model predictive control of an asymmetric flying capacitor converter," *IEEE Trans. Ind. Electron.*, vol. 56, no. 6, pp. 1839–1846, Jun. 2009.

[12] M. Odavic, V. Biagini, P. Zanchetta, M. Sumner, and M. Degano, "Onesample-period-ahead predictive current control for high-performance active shunt power filters," *Power Electronics, IET*, vol. 4, no. 4, pp. 414–423, Apr. 2011.

[13] N. G. Hingorani, "Introducing Custom Power," *IEEE Spectrum*, vol. 32, no.6, June 1995, pp. 41- 48.

[14] P.W. Lehn and M.R. Iravani, " Experimental Evaluation of STATCOM closed loop dynamics," *IEEE Transaction on Power Delivery*, vol. 13. no. 4, Oct. 1998, pp. 1378-1384.

[15] H. Akagi, "Trends in Active Power Line Conditioning," *IEEE Transaction on Power Electronics*, vol. 9. no. 3, May. 1994, pp. 263-268.

[16] Q.-N. Trinh and H.-H. Lee, "An advanced current control strategy for three-phase shunt active power filters," *IEEE Trans. Ind. Electron.*, vol. 60, no. 12, pp. 5400–5410, Dec. 2013.

[17] F. Barrero, S. Martinez, P.M. Yeves and P.M. Martinez, "Active Power Filters for Line Conditioning; A critical Evaluation," *IEEE Transaction on Power Delivery*, vol. 15, no. 1, Jan. 2000, pp. 319-325.