



## Bus Detection System for Blind People Using RFID

Abhishek Kumar Singh<sup>1</sup>; Ravi Kumar<sup>2</sup> & Dr.T.Saravanan<sup>3</sup>

1,2 UG Student, Dept. Of Electronics and Telecommunication Engineering, Bharath University, India

[itsabhisheksingh17@gmail.com](mailto:itsabhisheksingh17@gmail.com); [ravisingh7418@gmail.com](mailto:ravisingh7418@gmail.com)

3, Associate Professor, Dept. Of Electronics and Telecommunication Engineering, Bharath University, India

### ABSTRACT

*This paper outlines implementation of RFID for a bus detection mechanism to help blind in travelling from one place to another. Generally, journey in a bus is a safe and comfort factor but navigation in outdoor environments is highly difficult for those who have congenital blindness or blindness from a very young age. Several solutions have been proposed like walking stick or white cane guide dogs and GPS guidelines to deal with this difficulty. Although some of them have shown to be useful in real scenarios, they involve an important deployment effort or use artifacts that are not natural for blind users. Therefore, this paper aims to develop a bus detection prototype using Radio Frequency Identification (RFID) for blind. RFID has the potential to be a useful aid with further standardization of RFID tags and improvement of current RFID readers. Interfacing reader with microcontroller (ATMEGA328-PU), using IR sensor for wireless communication design aids in improved. Radio Frequency Identification (RFID) has been an emerging technology in recent years. In the recent few years there have been a lot of advancements in the field of RFID. The application of RFID technology have been numerous and the usage of this technology has led to many application specific designs and models that are today being used in many control system. The purpose of this paper will be to develop a design and propose a plan to implement RFID technology that will help the blind people navigate in outdoor environment. This system will help us to understand and develop a prototype model which will be used as a system by people to fulfill their requirement of navigation and identification.*

**KEYWORDS:** PIC16F877A Microcontroller; RFID reader and tag; VOICE IC; Buzzer; Ultrasonic sensor; LCD

### INTRODUCTION

In the recent few years there have been a lot of advancements in the field of RFID. The application of RFID technology have been numerous and usage of this technology has led to many application specific designs and models that are today being used in many control system. The purpose of this paper will be to develop a design and propose a plan to implement RFID Radio Frequency Identification (RFID) has been an emerging technology in technology that will help the blind people navigate in outdoor environment. This system will help us to understand and develop a prototype model which will be used as a system by people to fulfill their requirement of navigation and identification. This will bring into the market the application of RFID technology towards a social cause which will have its own economic future. For visually impaired people, outdoor pedestrian mobility is very difficult and often dangerous. The visually impaired commonly rely on a cane or walking stick and a guide dog to assist them in efficiently reaching a desired destination without harm. However, this approach is successful only if the majority of the path to the destination is already known to the blind (or to the guide dog). Buses play an important role for the transportation. For a majority of blind and visually impaired persons, public transport is the only viable mobility option to seek social connectivity. Those

people live in a limited environment and have difficulty to sense what happen around them, which reduces their activities is several fields, such as education and transportation since they depend only on their own intuition. Hence, we need to make their lives more comfortable by introducing a system that helps them enjoy transportation services independently and freely like ordinary people, without relying on others. Thus to help the visually impaired people and to make them to gain confidence to move around freely is to make use of RFID.

## II.BACKGROUND

The given RFID system consists of two fundamental components: tags and readers. The reader and the tag communicate via the transmission of electromagnetic waves. A reader is what the user interfaces with to transmit information to and from the tag, and tends to be much larger

than the tag. Tags store and process information, and can be extremely small, on the order of 3 mm. There are two types of tags : active and passive tags. Active RFID systems use self-powered RFID tags that continuously broadcast their own signal. Active RFID tags are commonly used as “beacons” to accurately track the real-time location of assets or in high speed environments such as tolling. Active tags provide a much longer read range than passive tags, but they are also much more expensive. Passive RFID systems use tags that are powered by the electromagnetic energy transmitted from an RFID reader. Passive RFID tags have applications including access control, tool tracking, race timing, supply chain management , smart labels, and more. The lower price point per tag make employing passive RFID systems economical for many industries. To intimate the presence of a blind person in the bus stop to the bus driver through wireless communication we make use of IR sensor. The IR Sensor-Single is a general

purpose proximity sensor that offers important advantages as a form of wireless communication. The purpose here is to provide a generic solution for implementing an IR transmitter (a remote control device) and receiver. We make use of IR sensor to help the blind while boarding the bus. Here we use it for collision detection for the blind while boarding bus to detect bus door. Also we use a mike setup interfaced to microcontroller (ATMEGA328-PU) mounted on arduino board (UNO) for the sake of destination input from the blind at the bus stop.

## DESIGN AND IMPLEMENTATION

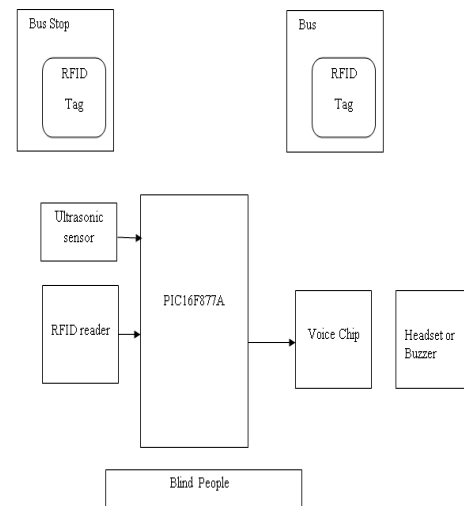

Block Diagram

## EXECUTION AND WORKING OF RFID IN BLIND AID.

The working of the product is split into Four parts 1. Signaling to bus driver. 2. Destination input (voice) by the blind . 3. Tag identification and destination matching. 4. Buzzering and bus boarding using IR sensor.

## PIC MICROCONTROLLERS

Microchip Technologies to its single chip microcontrollers. These devices have been phenomenally successful in the market for many reasons, the most significant ones are mentioned below. PIC micros have grown in steadily in popularity over the last decade, ever since their inception into the market in The term PIC, or Peripheral Interface Controller, is the name given by the early 1990s. PIC micros have grown to become the most widely used microcontrollers in the 8-bit microcontroller segment. The PIC16F877 is 40 pin IC. There are six ports in this microcontroller. Namely PORT A, PORT B, PORT C, PORT D and PORT E. Among these ports PORT B, PORT C and PORT D contains 8-pins, where PORTA contains 6-pins and PORT E contains 3-pins. Each pin in the ports can be used as either input or output pins. Before using the port pins as input or output, directions should be given in TRIS register. For example setting all the bits in TRIS D register indicates all the pins in PORT D are used input pins. Clearing all the bits in TRIS D register indicates all the pins in PORT D are used as output pins. Likewise TRIS A, TRIS B, TRIS C, TRIS E registers available for PORT A, PORT B, PORT C and PORT E.

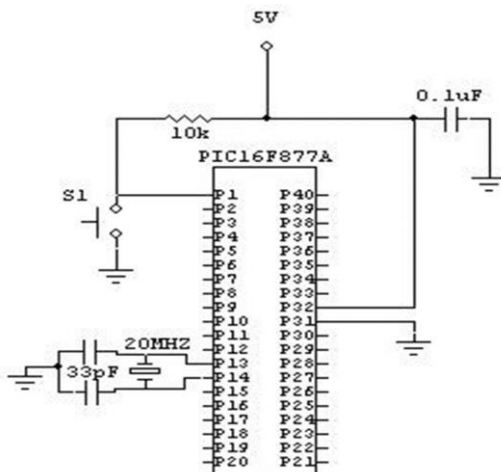

PIC MICROCONTROLLERS

## Signaling to bus driver.

This first step of application is to intimate the bus driver about the blind who is waiting in the bus stop so that the driver can provide a special attention at him/her while he/she is boarding bus. To implement which we can consider important advantages as a form of wireless communication of transmitters and receivers nature of infrared remote control protocols using STM32F0xx and STM32F3xx microcontrollers. So this section has two module IR transmitter and receiver module.

## IR transmitter module:

The IR transmitter module has a TX-IR LED which is an infrared transmitter designed for infrared serial data links and remote control applications. Data present is modulated at the selected carrier frequency of 36 kHz or 40 kHz providing a simple, single-chip solution for infrared data communications and remote control applications. An infrared interface (IRTIM) for remote control is available on the STM32F0xx and STM32F3xx devices. It can be used with an IR LED to perform remote control functionality. The IR digital interface is designed to output a digital signal towards the receiver through wireless communication.

## IR receiver module:

At the receiver side the IR pulses are modulated at around 36 kHz, 38 kHz or 40 kHz. The IR transmitted signal tries to lock that signal which is operating on the same frequency. The easiest way to receive these pulses is to use an integrated IR receiver/demodulator module which is a 3-pin device that receive the infrared burst and output the demodulated bit stream on the output pin which is connected directly to buzzer which beeps on receiving signal from transmitter intimating bus driver about blind waiting in the bus stop.

## Destination input (voice) by the blind.

The speech recognition system is a completely assembled and easy to use programmable speech recognition circuit. Programmable, in the sense that the

words (or vocal utterances) we want the circuit to recognize can be trained. This board allows us to experiment with many facets of speech recognition technology. This device can hear all sounds of the frequency between 20Hz to 20KHz. It has 8 bit data out which can be interfaced with any microcontroller for further use. In this application we store output on pic microcontroller for further development (identifying the match with the data stored in the tag attached to bus).

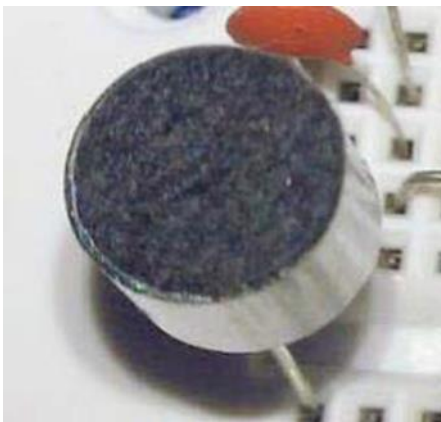

Mic

### RFID Tag:

The RFID tag or transponder has a sequence of metal pins or a bar code strip made of a magnetic material (differ from tags). The sequence of the metal pins or the bar code has a digital meaning behind it and it is unique to the particular tag. When the tag is interpreted or decoded, the sequence is displayed as numbers unique to the tag. Since it makes use of the Radio frequency interference technique, radio frequency helps in decoding the information. Each RFID tag has its own identification number i.e. Electronic Code Number (ECN). RFID tags can store more than just a tag ID. This additional memory on the tag is of Electrically Erasable Programmable Read-Only Memory (EEPROM) type. Data on an RFID tag can be updated through local processing. The idea is to find a suitable data format for data stored in the tags.

RFID Reader the radio frequency used to decode the data in the RFID tag is produced by the RFID reader. When a radio frequency wave interacts with an RFID tag, the pins or the bar code energizes (only in passive tag) and produces its own magnetic field which has a unique interference pattern which when read by the RFID reader would obtain the unique number designated to the corresponding RFID tag. Thus the RFID reader obtains the address of the desired RFID tag (the address defers from each tag). This identified tag when attached to a real object (example: bus) will be the reference to that object. Thus the object is indirectly detected. The below figure depicts the stages of RFID communication.

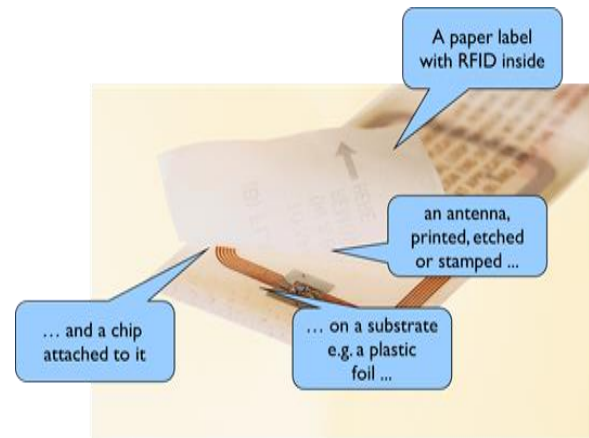

RFID Tag:

Fig 4 RFID Communication

1. The processor controlling RFID sending/receiving.
2. The antenna sending high frequency electromagnetic waves out.
3. The transponder, or tag, which converts the waves into an electric current.
4. The tag responding with its own unique radio wave.
5. The reader unit receiving the tag's wave, which is then processed to retrieve information.

Now destination voice input need to be matched with the tag data just decoded which is the responsibility of comparator in pic microcontroller to compare with and providing the output result in the form of buzzer on finding match. For a microcontroller ATmega328 running at 16MHz, an interfaced buzzer/condenser can produce output of 1 or 2 watt.



## Buzz ring and bus boarding using IR sensor.

The IR Sensor-Single is a general purpose proximity sensor. Here we use it for collision detection (Blind while boarding bus to detect bus door). The module consist of a IR emitter and IR receiver pair. The high precision IR Receiver always detects a IR signal. The module consists of 358 comparator IC. The output of sensor is high whenever it IR frequency and low otherwise. The on-board LED indicator helps user to check status of the sensor without using any additional hardware. The power consumption of this module is low. The output line of IR sensor is provided as an input to microcontroller (ATMEGA328) which provides a buzzer output through D6 pin on controller.

IR sensor with 358 comparator IC.

## RFID Reader

The RFID device serves the same purpose as a bar code or a magnetic strip on the back of a credit card or ATM card; it provides a unique identifier for that object.

- And, just as a bar code or magnetic strip must be scanned to get the information, the RFID device must be scanned to retrieve the identifying information.
- A significant advantage of RFID devices over the others mentioned above is that the RFID device does not need to be positioned precisely relative to the scanner.
- We're all familiar with the difficulty that store checkout clerks sometimes have in making sure that a barcode can be read. And obviously, credit cards and ATM cards must be swiped through a special reader.

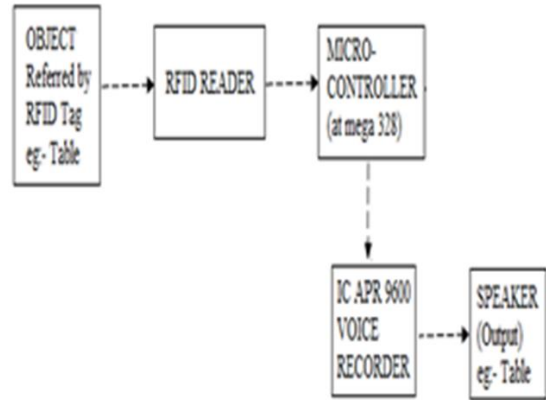

RFID Reader

## RFID Communication

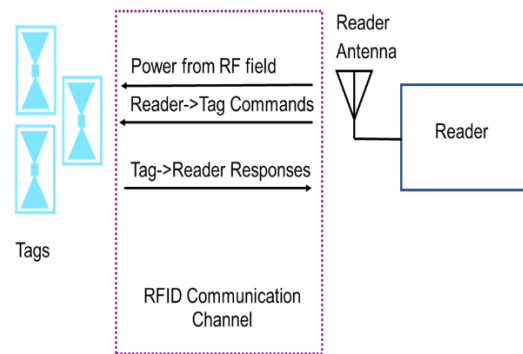

RFID Communication

## EXISTING SYSTEM

Several systems had been proposed for guiding blind people. Here, we will just mention the most related ones to the theme of our system. One of these systems is a central announcement system based on Bluetooth technology.

In this system, Bluetooth devices are installed in both the bus and the bus station which are connected to a processing subsystem. When a bus approaches the station, the two Bluetooth devices of the bus and the station will connect to each other.

After that, the bus Bluetooth device will transmit a message containing bus information to the station's processing subsystem. The trans-mitted message will be read by a text to speech converter which is

interfaced with the processing subsystem in the bus station.

Then, an announcement message that contains the bus information will be generated through a speaker. But there are two disadvantages in this system: it allows connection of only two devices at once and the connection between devices may be lost under certain conditions.

1. It is not Efficient
2. Ultrasonic sensors used to find the bus
3. More noise

## PROPOSED SYSTEM

This Bus detection device for the blind using passive RFID application (ABSTRACT) project demonstrates the concept of bus detection system by the blind people using RFID.

In which the blind people having RFID reader with some microcontroller module which gives the buzzer sound whenever the specific bus comes, the bus is equipped with RFID tag.

Whenever bus comes at bus stop the blind person who is provided with RFID reader get signal as it reads tag. the project is aims to develop a bus detection prototype using Radio Frequency Identification (RFID) for the blind.

The paper covers brief idea about the blind and RFID system, review relevant papers and summary of current research. The review of RFID system compare between families of auto-ID technology, the basic principle of RFID, the type of RFID tagging and the antenna characteristic.

1. It is Efficient.
2. RFID reader and tag were proposed.
3. Less noise
4. Mobility

## Ultrasonic Sensors

Bats are wonderful creatures. Blind from the eyes and yet a vision so precise that could distinguish between a moth and a broken leaf even when flying at full speed. No doubt the vision is sharper than ours and is much beyond human capabilities of seeing, but is certainly not beyond our understanding. **Ultrasonic ranging** is the technique used by bats and many other creatures of the animal kingdom for navigational purposes. In a bid to imitate the ways of nature to obtain an edge over everything, we humans have not only understood it but have successfully imitated some of these manifestations and harnessed their potential to the greatest extent.

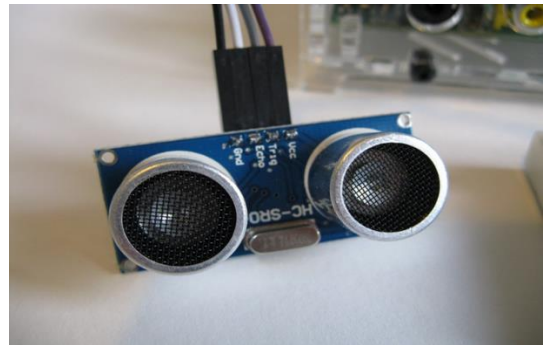

Ultrasonic Sensors

## MAX 232

The **MAX232** is an integrated circuit, first created by Maxim Integrated Products, that converts signals from an RS-232 serial port to signals suitable for use in TTL compatible digital logic circuits. The MAX232 is a dual driver/receiver and typically converts the RX, TX, CTS and RTS signals.

- MAX232 device is a dual driver/receiver that includes a capacitive voltage generator to supply RS-232 voltage levels from a single 5-V supply.
- Each receiver converts RS-232 inputs to 5-V TTL/CMOS levels. These receivers have a

typical threshold of 1.3 V and a typical hysteresis of 0.5 V, and can accept 30-V inputs.

- Each driver converts TTL/CMOS input levels into RS-232 levels.

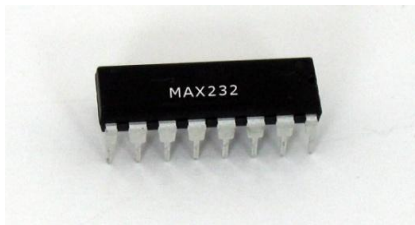

MAX 232

### Transformer:

The function of the transformer is to step down the available ac source of 230 volts. The transformer selected is a 0-12v transformer. The current rating of the transformer is 1 A on the low voltage side. Since we require +5V. DC sources with a common ground. The 230 AC voltages are stepped down using this step down transformer. At the secondary the 230v AC it is reduced to 12V RMS outputs measured with respect to ground.

### Voltage Supply Units:

The function of the voltage regulator units are that when the output of the filters provide DC of a higher value than that is required the output of the regulator r is constant of say + 5 volts. In spite of the variations in the supply voltage the output remains constant at the stipulated level.

### LCD Display

Liquid crystal displays (LCDs) have materials which combine the properties of both liquids and crystals. Rather than having a melting point, they have a temperature range within which the molecules are almost as mobile as they would be in a liquid, but are grouped together in an ordered form similar to a crystal. An LCD consists of two glass panels, with the liquid crystal material sandwiched in between them. The

inner surface of the glass plates are coated with transparent electrodes which define the character, symbols or patterns to be displayed polymeric layers are present in between the electrodes and the liquid crystal, which makes the liquid crystal molecules to maintain a defined orientation angle.

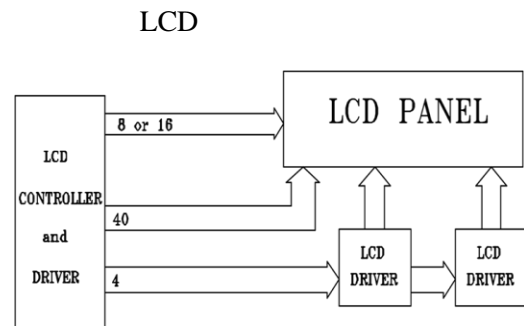

LCD Panel

### How it Works:

Generally, journey in a bus and train is a safe and comfort factor, but due to increase in number of passengers its going be tougher now a days and it will be more difficult for blind people to travel. So, we can make a system which can help blind people to find the bus and train at the stop as they cannot able to see which bus is coming on the bus stop. By providing a device which can help them to know which bus is coming on bus stop.

In this project we have microcontroller, RFID reader and RFID tag with as basic blocks. This system demonstrates the concept of bus detection system by the blind people using RFID.

In which the blind people having RFID reader with some micro controller module which gives the buzzer sound or can connect with headset whenever the specific bus comes, the bus is equipped with RFID tag.

- Bus stop has RFID tag, whenever bus comes at bus stop the blind person who is provided with RFID reader get signal as it reads tag. RFID is a wireless personal area networking standard
- which provides features like non line of sight detection of tag by RFID reader from a distance of up to 1.5 meter. This feature helps in using RFID in many applications.
- The summary of current research discussed about the development of prototype, the database system, the output mechanism and integration between hardware and software.
- Database management will provided. The information such as bus route, final destination and bus number are also provided. This paper also describes the future work intended to be done.

## RESULT

This paper presents a bus detection system using RFID technology that aims to ease the traveling and movement of blind people. The proposed system consists of two detection subsystems; one on the buses and the other on the bus stations, database system and a website. In the bus detection subsystem, the nearby stations will be easily detected and then announced through a voice message inside the bus. Moreover, any existing blind person in the surrounding area of the station will be detected by the bus subsystem to alert the bus driver about the number of blind persons. In the bus station subsystem, the coming buses will be detected and then announced in the station in order to alert the blind people. A complete system prototype has been constructed and tested to validate the

proposed system. The results show that the system performance is promising in terms of system functionality, safety, and cost.

## FINAL DESIGN



## CONCLUSION

An interactive wireless communication aid system for the visually impaired to use city buses was developed in this study. Using the ultra-high frequency radio waves, we have shown implementing a system which will use the RFID tag and reader setup along with customized program that will help the blind in identifying exact bus. Results of tests indicated that this system could help users to successfully board their desired buses, using the interactive communication modules. Thus showing the possibility of using the RFID technology to help the blind.

## REFERENCE

- [1] Bin Ding Sch. of Manage. Univ. of Sci. & Technol. Of China, "The Research on Blind Navigation System Based on RFID", ISBN: 978-1-4244-1311-9, Page(s) : 2058 – 2061, 21-25 Sept. 2007. <http://ieeexplore.ieee.org/xpl/articleDetails.jsp?tp=&ar>



[number=4340289&queryText%3Dblind+bus+navigation+system+using+rfid.](#)

[2]Lavanya G, Preethy W, Shameem A, Sushmitha R, "Passenger BUS Alert System for Easy Navigation of Blind", ISBN: 978-1-4673-4921-5, Page(s): 798 – 802, 20- 21 March 2013.

<http://ieeexplore.ieee.org/stamp/stamp.jsp?tp=&arnumber=6529043>.

### **Author Bibliography:**



#### **ABHISHEK KUMAR SINGH**

Pursuing bachelor of technology in electronics & Telecommunication engineering from Bharath University, Chennai, India

Email: [itsabhisheksingh17@gmail.com](mailto:itsabhisheksingh17@gmail.com)



#### **RAVI KUMAR**

Pursuing bachelor of technology in electronics & Telecommunication engineering from Bharath University, Chennai, India

Email: [ravingh7418@gmail.com](mailto:ravingh7418@gmail.com)