

Development of Motorized Car Jack

Ravi Kumar D

Assistant Professor Mechanical Engineering SRM University

Shubham Choudhary

U.G. Student Mechanical Engineering SRM University

Devanshu Pasbola

U.G. Student Mechanical engineering SRM University

Shubham Dabral

U.G. Student Mechanical Engineering SRM University

Abstract: Tire puncture can be commonly observed now-a-days. Car jack comes with vehicles requires users to apply manual force to lift a vehicle. This paper is targeted to analyze the development in existing scissor car jack in order to make load lifting easier by utilizing Car battery(12V) which can be used in emergency situations. In this design, the cigarette lighter receptacle point is connected in car, which drives the power from the car battery(12V), this will run the DC motor and thus connected power screw is rotated. By this, the car jack will lift the vehicle. The contractions or expansion movement of car jack can be controlled by a joystick as per requirements. This modified car jack can be easily operated by any person and it saves time, hence reduce wastage of human efforts and time. The design of this car jack is being developed in SolidWorks 2010 software. Manufacturing and fabrication work have been done using milling, drilling, grinding and threading machines. The modified car jack is tested and implementing of design can solve ergonomics problems.

Keywords: Car Battery; DC Moto; Solid Works 2010; Ergonomics; scissor jack

Introduction:

During sideroad emergency like tire puncher, scissor car jack is required to lift the vehicle. A mechanical jack can lift all or part of a vehicle into the air for repairing breakdowns or vehicle maintenance. Changing the flat tire is a laborious activity. These days many varieties of car jack have been developed for lifting an automobile from ground. However, available car jacks are manually operated thus requires extra physical efforts from the user. It is difficult for elderly and handicapped to operate such jacks. For using these jacks operators are required to be in prolonged squatting or bent position. Working in

these positions for some duration is boisterous. This can lead to backache problem.

The automobile workstations are equipped with hi-tech car lifting system, wherein car are raised and lowered via electrically powered system. However, due to their high cost, maintenance and size, such lifts can neither be placed in car nor be owned by car owner. Motorized portable car jack not only reduce human efforts in automobile but also safe time needed to repair the automobile. Such feature is beneficial for repairing vehicle on the side of the roadway. This modified car jack is designed so that it can be easily operated, safe and can lift or lower the vehicle without much

physical effort. This paper focuses on design and analyze modified car jack.

Working:

Under favorable conditions, the jack can lift a vehicle chassis when it comes in contact with upper plate, which is caused by rotation of power screw through the electric power taken from car battery(12V) via cigarette lighter receptacle plugged in car. Firstly motorized jack will be placed under car chassis with some clearance space between top plate and chassis. The cigarette lighter receptacle connected with jack will be plugged in port, thus connecting directly with car battery. When direction of movement

will be given by joystick, the power will be taken and motor starts rotating. Motor will transfer its rotating speed to the pinion gear meshing with a bigger gear which is connected to power screw and it will rotate. On giving UP direction, the power screw will rotate within threaded cubical bore in clock-wise direction, which will cause links to move along threaded portion towards each other in load raising process and vice versa. During loading process, jack will eliminate the clearance space between itself and chassis by rising up. When chassis will come in contact with jack, the weight of car will gradually transfer to jack. These developed forces will be distributed among links and cubical bore. The force transmitted to cube will be transferred to screw threads.

COMPONENTS OF MOTORIZED JACK:

The main components which are essential for development of motorized scissor car jack are:

1. Modified jack with new dimensions
2. Power screw
3. DC motor (12V, 10A)
4. Cigarette lighter receptacle

Component No.	Name	Quantity
1	Top Plate	1
2	Links	8
3	DC Motors	1
4	Power Screw	1
5	Joystick	1
6	Base	1
7	Cigarette Lighter Receptacle	1
8	Bolt(8mm)	8
9	Bolt(14mm)	4
10	Cubical Bore	1
11	Motor Bracket	1

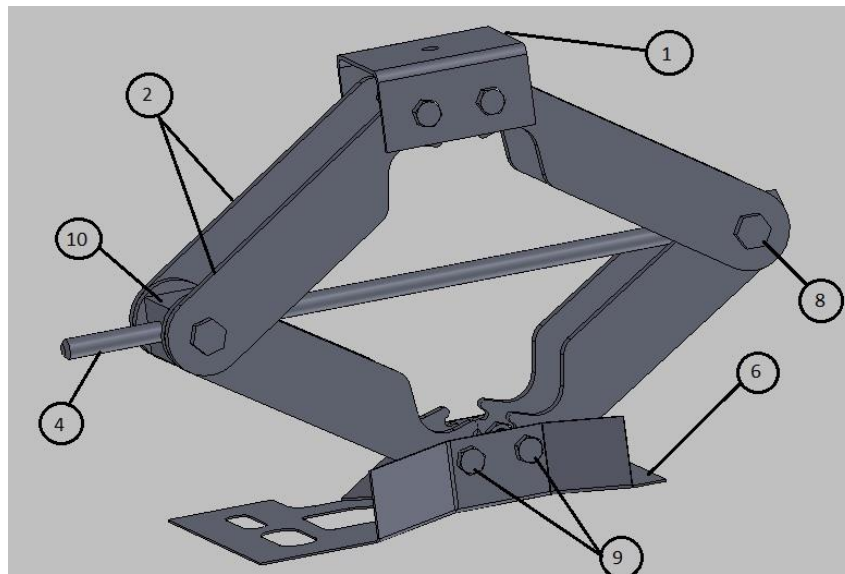

MATERIAL SELECTION:

For most of the standard jacks, the material used is described as “**Heavy Duty Steel**”. The **American Iron and Steel Institute (AISI)** developed a classification system for different types of iron and steel alloys. After some research, it was determined that a **Nickel-Chromium-Molybdenum steel alloy** may be possible material to construct the proposed scissor jack. The particular alloy has a classification of **AISI 4340** engineering steel in industries use. However, if after Analysis, it is discovered that the material affects the force of design, it may be changed to something more appropriate.

High Strength Low-Alloy Steel (40Ni2Cr1Mo28/AISI 4340) is used for **links and top plate**.

PropertiesOf AISI 4340

Ultimate Tensile Strength	931 MPa	13500psi
Yield Tensile Strength	834 MPa	121000psi
Elongation at Break	20.2%	20.2%
Modulus of Elasticity	205 GPa	29700ksi
Poissons’s ratio	0.29	0.29
Shear Modulus	80 GPa	11600psi
Bulk Modulus	140 GPa	11600ksi

Material used for **Base and Motor** Mounting is **High Alloy Steel PlatesDENERTIA-N8**

Material of **Nuts** is **ASTM A193**

Material of **Bolts** is **ASTM A194**

CALCULATIONS:

We have brought the used battery and parts like Links and Power Screw are modified in design and replaced. Design of Power screw and side members is as follows:

1. Assumptions:

- The ground clearance of the car is assumed to be 165mm after observing various car's specifications.
- When jack lifts car from ground i.e, the scissor jack is carrying maximum load, the jack is assumed to move in vertical direction only, by 50mm.
- The scissor jack supports quarter of total vehicle mass only, which lies between 300kg/3000N to 1000kg/10000N. For safety design weight is taken as 400kg or 4000N.

2. Conditions taken for initiating design:

Used input parameters are taken by making study of cars specifications and different loading conditions. Some input are taken by practical analysis of car lifting conditions while others taken by failed conditions.

a. Input

- Maximum car weight = 400kg/4000N.
- Ground clearance = 165mm.
- Maximum lift = 50mm.
- Link length = 186mm

2.2. Derived

- Working conditions of road : On horizontal road surface.
- Angles between link with the horizontal axis (θ):

- Angle in top most position(θ_{max}):

$$\tan \theta_{max} = \frac{155.5}{55.25} = 70.4395^{\circ}$$

- Angle in lower most position(θ_{min}):

$$\tan \theta_{min} = \frac{57.5}{136.5} = 22.84^{\circ}$$

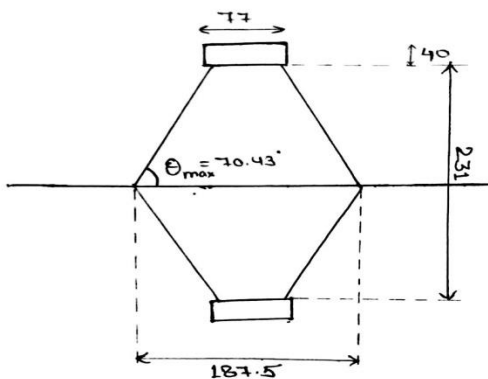

:Top Position

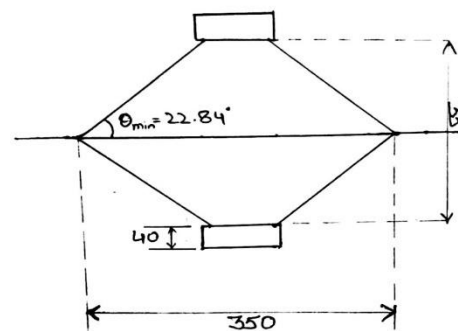

: Lower Position

3. Force analysis in Scissor jack:

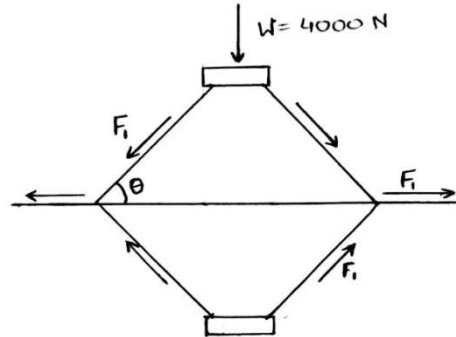

4. Design of screw:

$$\sum F_H = 0$$

$$\therefore (F_1 * \cos\theta) - \frac{w}{2} = 0 \text{ or } F_1 = \frac{w * \cos\theta}{2 * \sin\theta} = \frac{w}{\tan\theta}$$

Total axial force in screw (W_s):

$$W_s = 2F_1 = \frac{2 * w}{2 * \tan\theta}$$

Hence, the axial force (W_s) in a screw is maximum when (θ) is minimum.

$$\therefore W_s = \frac{w}{(\tan\theta)_{\min}} = \frac{4000}{\tan 22.84} = 9497.05 \text{ N}$$

From table shown above, we have $\sigma_{yt} = 834 \text{ N/mm}^2$, and $\tau_s = \frac{\sigma_{yt}}{2} = 417 \text{ N/mm}^2$

Assume factor of safety (N) = 3, Service factor (k) = 1.6

$$\therefore \sigma_{\text{allowable}} = \frac{\sigma_{yt}}{k * N} = \frac{834}{1.6 * 3} = 173.75 \text{ N/mm}^2$$

$$\therefore \tau_{\text{allowable}} = \frac{\sigma_{\text{allowable}}}{2} = \frac{173.75}{2} = 86.875 \text{ N/mm}^2$$

The direct tensile stress in screw body is given as follow:

$$\sigma_t = \frac{W_s}{\frac{\pi}{4} * d^2} \text{ or } 173.75 = \frac{9497.05}{\frac{\pi}{4} * d^2}$$

$d = 9.2927 \text{ mm}$, taking $d = 11.5 \text{ mm}$ (standard size)

Selecting standard screw :

Core diameter (d) = 11.5 mm.

Outer diameter (d_2) = 16 mm.

Mean diameter (D) = 14mm.

Pitch (p) = 3 mm.

Length of screw (L)=350+2*16 = 382 mm.

Torque required for overcoming the thread friction (T_f):

For acme thread, $\alpha = 14.5^\circ$.

$$\text{Helix angle } (\lambda) = \tan^{-1} \frac{1}{\pi * D} = \tan^{-1} \frac{1}{\pi * D} = 1.302^\circ$$

$$\text{Coefficient of friction } (\mu') = \frac{\mu}{\cos \alpha} = \frac{0.15}{\cos 14.5} = 0.154$$

$$\text{Friction angle } (\phi) = \tan^{-1} \mu' = \tan^{-1} 0.154 = 8.75^\circ$$

$$\text{Required Torque } (T_f) = \frac{W * D}{2 * (\tan \theta)_{\min}} * \tan (\phi + \lambda) = \frac{4000 * 14}{2 * \tan 22.84} * \tan (8.75 + 1.302) = 11784.33 \text{ N-mm}$$

$$\text{Efficiency of threads } (\eta) = \frac{1 - \sin \phi}{1 + \sin \phi} = \frac{1 - \sin 8.75}{1 + \sin 8.75} = 73.58\%$$

$$\text{Actual torque required } (T) = \frac{T_f}{\eta} = \frac{11784.33}{0.7358} = 16015.67 \text{ N-mm}$$

$$\text{The direct tensile stress in screw body } (\sigma_t) = \frac{W_s}{\frac{\pi}{4} * d^2} = \frac{9497.05}{\frac{\pi}{4} * 11.5^2} = 91.433 \text{ N/mm}^2$$

$$\text{Shear stress due to torque } (\tau_s) = \frac{16 * T}{\pi * d^3} = \frac{16 * 16015.67}{\pi * 11.5^3} = 53.6317 \text{ N/mm}^2$$

$$\text{Maximum principle stress theory } (\sigma) = \frac{\sigma_t}{2} + 0.5 \sqrt{(\sigma_t)^2 + 4 * (\tau_s)^2} = \frac{91.433}{2} + 0.5 \sqrt{(91.433)^2 + 4 * (53.6317)^2}$$

$$\sigma = 116.1885 \text{ N/mm}^2$$

$$\sigma = 116.1885 < 173.75 \text{ N/mm}^2$$

Hence, design is safe.

$$\text{Maximum principle stress theory } (\tau) = \sqrt{\left(\frac{\sigma_t}{2}\right)^2 + (\tau_s)^2} = \sqrt{\left(\frac{91.433}{2}\right)^2 + (53.6317)^2}$$

$$\tau = 70.47 \text{ N/mm}^2$$

$$\tau = 70.47 < 86.875 \text{ N/mm}^2$$

Hence, design is safe.

CONCLUSION:

The existing car jack was developed by making small adjustments and using an electric motor to rotate power screw. The car battery (12V) is power source to motor, to make load lifting easier. The advantages of this modified jack are that it will save time, human efforts and easier to operate. Thereby effectively eliminating the problems related to Ergonomics-which is most

fundamental concept of designing process. On observing all available car jacks in the markets, this prototype has been improved by few alterations in some features and design.

The objectives are to design a car jack that is safe, efficient, reliable and able to function with easy operating. Based upon testing and calculations, this car jack is considered safe to use under some specifications. Furthermore the



torque supplied to the system is more than enough to lift a car weighing around 1000kg. There are certain weak points which can be improved in designing and fabrication.

REFERENCES:

- [1] <http://www.matweb.com/search/datasheet.aspx?matguid=92b4c61e40d74cc9a8e233030f6413b6>
- [2] <http://asm.matweb.com/search/SpecificMaterial.asp?bassnum=M434AP>
- [3] <http://www.steel-grades.com/Steel-Grades/High-Alloy/denertia-n8.html>
- [4] http://www.pressbolt.com/astm_a193_a3_20_a182_a453_studbolts.html
- [5] **ASM Metals Reference Book**, Third edition, Michael Baucio, Ed. ASM International, Materials Park, OH, 1993.
- [6] **ASM Specialty Handbook - Carbon and Alloy Steels**, edited by J.R. Davis, Davis & Associates, ASM International, Metals Park, OH, (1996).
- [7] **Engineering Properties of Steels**, Philip D. Harvey, editor, American Society for Metals, Metals Park, OH, (1982).
- [8] **Metals Handbook**, Vol.1 - Properties and Selection: Irons, Steels, and High-Performance Alloys, ASM International 10th Ed. 1990.
- [9] **Metals Handbook**, Howard E. Boyer and Timothy L. Gall, Eds., American Society for Metals, Materials Park, OH, 1985.
- [10] **Physics for Scientists and Engineers with Modern Physics**, 2nd ed., Douglas C. Giancoli, Prentice Hall Publishers, Englewood Cliffs, NJ (1989)
- [11] **SAE Ferrous Materials Standards Manual**, 1999 ed., HS-30, Society of Automotive Engineers, Inc., Warrendale, PA, (1999).