

Ann Based Control Scheme for Hybrid Shunt Filter

A. Raviteja & S.Rajsekhar

P.G Scholar, Department of EEE, ASR College of Engineering & Technology, JNTUK, A.P
Assistant Professor, Department of EEE, ASR College of Engineering & Technology, JNTUK, A.P

ABSTRACT: *Hybrid active power filters comprises active power filters and passive filters. The inherent drawback that associated with active power filters lead to the development of hybrid power filters. An artificial neural network based control scheme for hybrid shunt filter is proposed in this project. In a hybrid active power filter, the active power filter is used to filter out the higher order harmonics. In addition to the active power filter tuned filters made up of passive components are used for elimination of 5th and 7th order harmonic frequencies are introduced. Combination of active and passive filters connected in shunt at point of common coupling considerably reduces the cost and size of active power filter and also effectively overcomes the problems that arise due to the usage of passive filters. The effectiveness of proposed filter topology and its control scheme are been verified by MATLAB/Simulink and Artificial Neural Network toolbox.*

Keywords: Non Linear Load; Hybrid; Filter; Compensation; ANN Control

1. INTRODUCTION

The extensive application of non linear loads in domestic, commercial, industrial sector causes power quality problems such as harmonic current, poor power factor, unbalance, voltage sag and swell, reactive power burden etc. Some of the examples of nonlinear loads are uncontrolled and controlled rectifiers; variable speed drives both Alternating Current and Direct Current, uninterrupted power supplies etc. These nonlinear loads may cause poor power factor and high degree of harmonics. Active power filter technology is the most efficient way to

compensate for reactive power and cancel lower harmonics

This paper emphasizes on elimination of current harmonics and reactive power compensation; hence shunt hybrid APF topology has been considered and control Scheme using Artificial Neural Network (ANN)

2. HYBRID ACTIVE POWER FILTER

The hybrid active power filter is nothing but the series combination of active power filter and the passive elements. The harmonics in the power system can be removed in the following ways.

- By providing a low impedance path to ground for harmonic signal.
- By injecting compensating signals which are in phase opposition with the harmonic signal present in the system.

For the first one we can use passive tuned filter and for the latter active filter can be used.

Active filter is connected in series with the passive filter through a coupling transformer.

3. SHUNT ACTIVE POWER FILTER

The basic principle of a shunt active power filter is that it generates a current equal and opposite in polarity to the harmonic current drawn by the load and injects it to the point of common coupling, thereby forcing the source current to be pure sinusoidal. The reference compensation signals are generated by making use of a control algorithm.

Apart from compensating the harmonics, the active power filters can supply the reactive power required for the load. Thus, an active power filter can compensate for a wide range of harmonic components and at the same time improve the power factor of the current.

4. CIRCUIT CONFIGURATION

Fig.1 shows a proposed system consisting of a Shunt active power filter and Passive filter. The purpose of using this combined system is to reduce the harmonics effectively. The power-factor also improved by using the combined system.

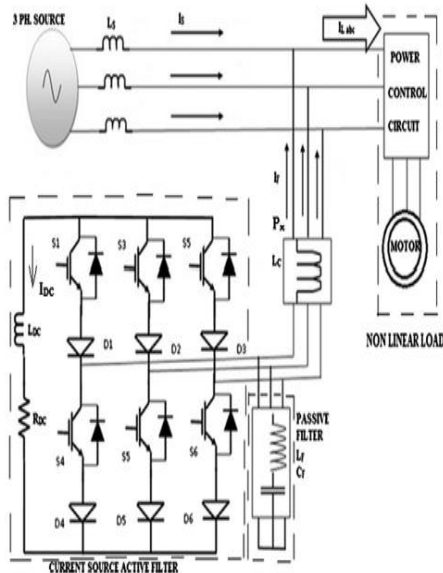

Figure 1: Circuit configuration of hybrid filter

The main circuit of the active filter is the VSI with PWM modulation using IGBT switches. The current source hybrid power filter is a combination of current source active power filter and passive LC filter. APF is an inverter circuit capable of producing the bidirectional compensating current components. A passive power filter consists of an inductor and a capacitor tuned for a fifth order harmonic frequency and seventh harmonic frequency. Current source realized with the inductor, is feeding a power converter which is considered as the harmonic source. The diodes in APF enable the device to withstand direct and reverse voltages produced by the DC link inductor. The inverter is connected in parallel with the load at PCC using coupling inductor. The power devices of the CSAPF are rated for the maximum possible voltage and current.

The passive power filter (PPF) is connected in parallel with CSAPF is tuned to mitigate the fifth order harmonic current thereby reducing the power requirement of APF. The value of PPF components are calculated with the harmonic frequency which has to be eliminated. The L and C are determined by using the Eq. (1). The value of the L and C for the

given frequency is determined with large value for C and small L for minimizing the ripples. For compensation of nth harmonic current, passive filter inductance, L and capacitance, CF are determined by the equation,

$$n\omega_1 L_F = \frac{1}{n\omega_1 C_F} \quad (1)$$

'n' is harmonic order and 'ω' is the fundamental frequency.

5. ARTIFICIAL NEURAL NETWORK

An ANN consists of a group of elementary processing items which communicate by using sending signals to one another over a large number of weighted connections. A set of significant points of ANN are:

- A group of processing units ('neurons,' 'cells').
- A state of activation y_k for each unit, which is similar to the output of the unit.
- Connections between the units. Normally each connection is defined via a weight w_{jk} which determines the effect which the signal of unit j has on unit k.
- A propagation rule, which determines the useful input s_k of a unit from its external inputs.
- An activation function F_k , which determines the new level of activation based on the effective input $s_k(t)$ and the current activation $y_k(t)$ (i.e., the update);
- An external input (aka bias, offset) θ_k for each unit;
- A method for information gathering
- An environment within which the system must operate, providing input signals and if necessary error signals.
- An activation function F_k , which determines the brand new state of activation depend on the useful input $s_k(t)$ and the current activation $y_k(t)$ (i.e., the update).
- An external input θ_k for each unit;
- A process for information collection
- An atmosphere inside which the system must need to operate, delivering input signals and if required error signals.

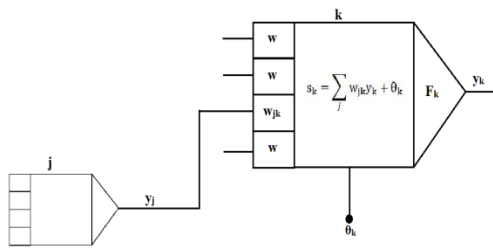

Fig 2 The basic components of an Artificial Neural Network

Artificial neural networks take different approach than conventional controllers. Artificial neural networks are divided into two types one is feed forward networks and another one is feedback networks. Feed forward artificial neural networks allow to travel signals in only one way. Whereas feedback networks can have signals travelling in both directions. The common type of artificial neural networks consists of three groups input layers are connected to hidden layers and hidden layers are connected to an output layers. The activity of input layers represents the raw information that is fed to the network. The activity of each hidden layer is determined by activity of input layers and weights of the connections between the input layers and hidden layers. The behaviour of the output layers depends on the activity of the hidden layers and the weights between hidden layers and output layers.

There are two different ways in which training can be implemented incremental mode and batch mode. In incremental mode gradient is computed and the weights are updated after each input is applied to the network. In batch mode all the inputs in the training set are enforced to the network before the weights are updated.

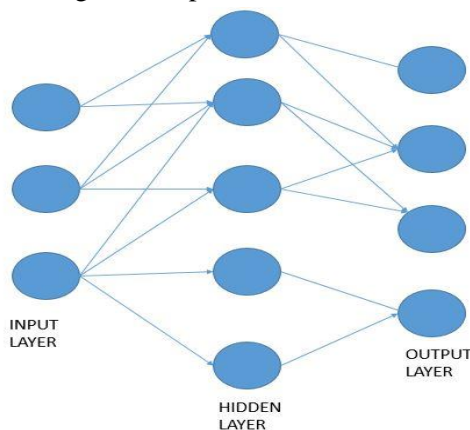

Fig 3-structure of basic layered ANN

5.1 ANN in control of Hybrid shunt filter

There are many conventional techniques to detect and compensate harmonic current. ANN is one of the modern techniques which are used in many areas of application including harmonic eliminations. Fig.4 shows an architecture of three-phase diagram of neural network controlled SAPF. A NN is used to control the compensating current injection with SAPF.

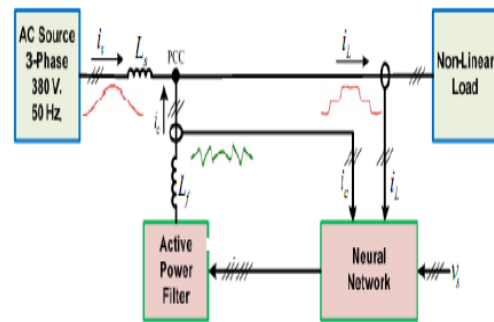

Fig 4- circuit configuration of hybrid filter using ANN control scheme

ANN is employed to substitute a harmonic detection component for the following reasons :

- To increase the processing speed, response speed, and convergence speed.
- To increase the robustness.
- To increase the efficiency and performance of the algorithm.
- To increase the steady-state stability.
- To increase an accuracy, precision, and validity of the evaluation process.
- To increase an adaptive ability, so that it can response in real time.
- To increase tracking ability.
- To provide the optimal solution.

6. SIMULATION RESULTS

The model for a three phase three wire shunt active power filter using SRF method has been successfully modeled and tested using MATLAB/SIMULINK toolbox. The performance of APF in steady state condition is evaluated using FFT simulation.

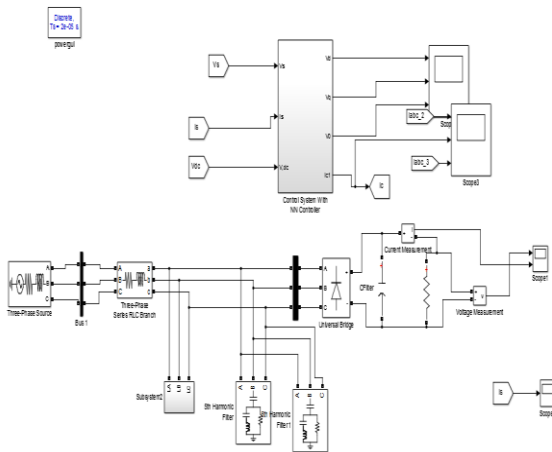

Figure 2: Simulation model of shunt HPF

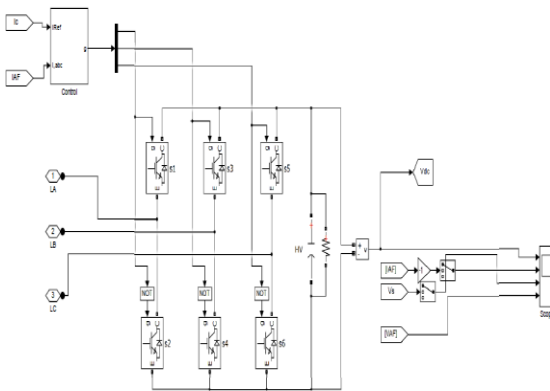

Figure 3: Simulation model of shunt APF

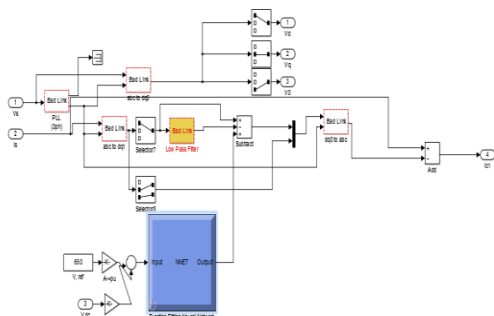

Figure 4: Simulation model of control system with ANN control

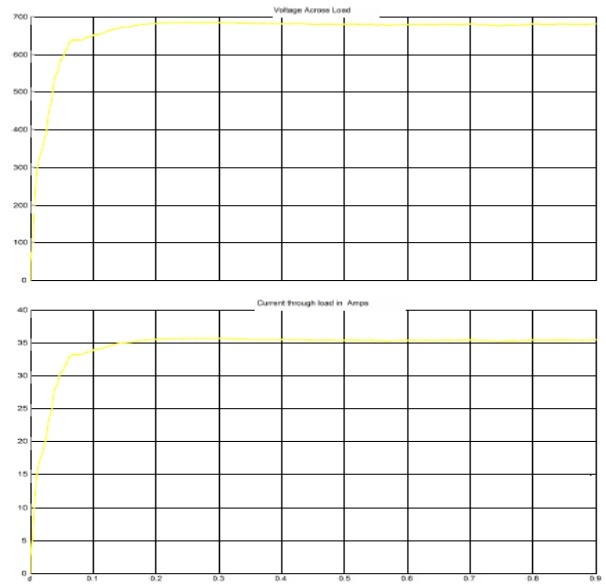

Figure 5: voltage and current across load with shunt HPF

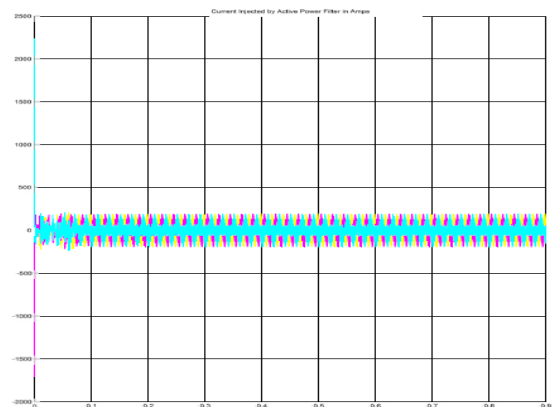

Figure 6: waveform of current injected from shunt APF

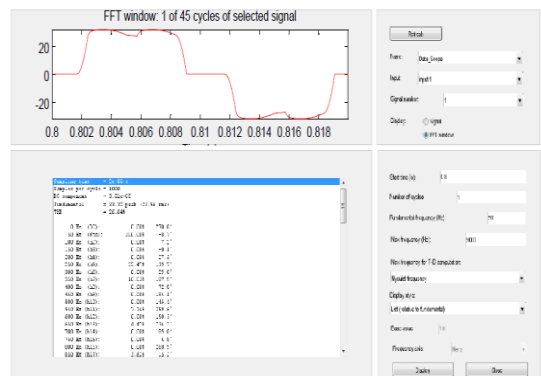

Figure 7: THD of nonlinear load without filter using FFT Analysis tool

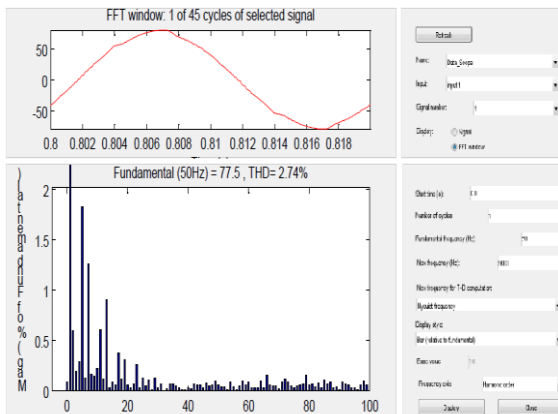

Figure 8: THD of nonlinear load with shunt HPF using FFT Analysis tool

7. CONCLUSION

Different power harmonic sources exist mainly due to nonlinear loads made up of power electronics devices. Active filters main principle of operation is injecting harmonic current into the ac system, of the same amplitude and reverse phase to that of the load current harmonics.. This will thus result in sinusoidal line currents and unity power factor in the input power system. An integration of ANN-based controller for a shunt-type APF has been presented in this paper to improve the convergence and reduce the computational requirement. The algorithm is derived from an ANN based PWM controller used to regulate the dc-link voltage in the APF.. The results from Experiments match well with the simulation, confirming the usefulness of proposed technique.

8. REFERENCES

[1] Avik Bhattacharya, and Chandan Chakraborty, “A Shunt Active Power Filter With Enhanced Performance Using ANN-Based Predictive and Adaptive Controllers” IEEE Transactions On Industrial Electronics, Vol. 58, No. 2, February 2011.

[2] Yang Han and Lin Xu “Design and Implementation of a Robust Predictive Control Scheme for Active Power Filters”. JPE 11-5-16

[3] Chongming Qiao and Keyue Ma Smedley; “Three-Phase Bipolar Mode Active Power Filters”, IEEE Transactions on Industry Applications, vol. 38, no. 1, January/February 2002

[4] Chongming Qiao ,Keyue M. Smedley and Franco Maddaleno; “A Single-Phase Active Power Filter With One-CycleControl Under Unipolar Operationn”, IEEE Transactions on Circuits and systems vol. 51, no. 8, august 2004.

[5] J. Sebastian Tepper, Juan W. Dixon,Gustavo Venegas, and Luis Morh; “A Simple Frequency-Independent Method for Calculating the Reactive and Harmonic Current in a Nonlinear Load”,IEEE Transactions on Industrial Electronics, vol. 43, no. 6, December 1996