

The Hybrid Net Switch Control Network Based On Can and Android

Nitish kumar¹ ; Rakesh Ranjan² & Dr.T.Sarvanan³

1,2 UG Student, Dept. Of Electronics and Telecommunication Engineering, Bharath University ,India

knitish911@gmail.com ; rkshranjan7200@gmail.com

3Associate Professor, Dept. Of Electronics and Telecommunication Engineering, Bharath University, India

ABSTRACT

Home automation is the residential extension of "building automation". It is automation of the home, housework or household activity. Home automation may include centralized control of lighting, HVAC (heating, ventilation and air conditioning), appliances, and other systems, to provide improved convenience, comfort, energy efficiency and security. Systems can range from simple remote control of lighting through to complex computer/micro-controller based networks with varying degrees of intelligence and automation. In simple installations, automation may be as straightforward as turning on the lights when a person enters the room. Home automation can also provide a remote interface to home appliances or the automation system itself, to provide control and monitoring on a smartphone or web browser.

KEYWORDS: Pic Microcontroller; CAN(Controller Area Network); Android; Bluetooth Module HC-05

1 INTRODUCTION

1.1 INTRODUCTION TO HOME AUTOMATION

Hardware and Software home Automation project based on Controller Area Network HAPCAN. These pages give information how to create your own home

automation system. Here you can find device schematics, firmware and PC software to program and control the system.

For many years, home automation has been visible to many, but accessible to only a few, because of inadequate integration of systems. A vast number of both standard and proprietary communication protocols are used, and systems are often difficult to install and configure so professional assistance is needed. This paper describes an open universal home automation framework enabling interoperability of multiple communication protocols. The framework can easily be expanded in order to support new protocols, and due to the open source nature of the frame work, this expansion can even be implemented by external vendors.

The goal of this application note is to explain some of the basics of CAN and show the benefits of choosing CAN for embedded systems networked applications. As our project is multi-slave single master message broadcast system that is suitable for systems where data contained in short messages are sent to the other devices another locations simultaneously. Because this mechanism is improve the compatibility of master and also central control of slave micro-controller through messages which are sent to all the nodes in a system. This project is especially suited to systems where consistency in the received messages at all the receiving nodes is needed. In this case, all nodes are notified of the rejection, ensuring the data consistency across the network. Messages are sent to all nodes, but their "message identifiers" indicate whether each node

should act on the message. Automation is also involved in building management system in which lights, temperature, security devices and other appliances are controlled through a high degree of computer involvement. In this report, all the devices which are used in building management system are control by a single controller using a wireless network.

II.BACKGROUND

In this project automation of home is done by android mobile phones with Bluetooth Communication. **Android** is a Linux-based operating system designed primarily for touch screen mobile devices such as smart phones and tablet computers with the Open source. Bluetooth and CAN protocol has used for reliable operation of data transmission. Bluetooth is standardized wireless guarantees the high level of compatibility among devices. Bluetooth devices connect to each other irrespective of their model. Bluetooth with the help of low power signals technology requires very less energy reducing the battery consumption or electrical power. CAN protocol is a two wire bus protocol which reduces the wiring complexity and easy to manage the data transmission with high speed.

DESIGN AND IMPLEMENTATION

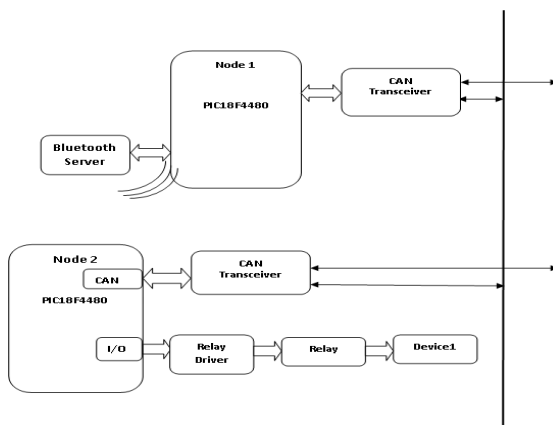

CONTROLLING UNIT

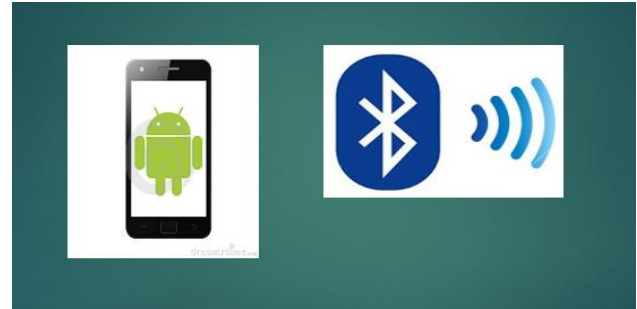

Here we are using Bluetooth server as a main input and the bluetooth is connected to the node one which is nothing but PIC Microcontroller and CAN transceiver is connected for the data transmission between the nodes. We can also call node one as a master node and node two as slave, The CAN lines are connected between two nodes. In this project we can add multiple nodes for operation. Node two is connected to relay driver for I/O of the devices. The devices are controlled by the android phone. Having Bluetooth module named Bluetooth HC05.

Android

Android is a mobile operating system (OS) currently developed by Google, based on the Linux kernel and designed primarily for touchscreen mobile devices such as smartphones and tablets. Android's user interface is mainly based on direct manipulation, using touch gestures that loosely correspond to real-world actions, such as swiping, tapping and pinching, to manipulate on-screen objects, along with a virtual keyboard for text input. In addition to touchscreen devices, Google has further developed Android TV for televisions, Android Auto for cars, and Android Wear for wrist watches, each with a specialized user interface. Variants of Android are also used on notebooks, game consoles, digital cameras, and other electronics.



Android

Android has a growing selection of third-party applications, which can be acquired by users by downloading and installing the application's APK (Android application package) file, or by downloading them using an application store program that allows users to install, update, and remove applications from their devices. Google Play Store is the primary application store installed on Android devices that comply with Google's compatibility requirements and license the Google Mobile Services software. Google Play Store allows users to browse, download and update applications published by Google and third-party developers

MICROCONTROLLER

A controller is used to control (makes sense!) some process or aspect of the environment. A typical microcontroller application is the monitoring of my house. As the temperature rises, the controller causes the windows to open. If the temperature goes above a certain threshold, the air conditioner is activated. If the system detects my mother-in-law approaching, the doors are locked and the windows barred. In addition, upon detecting that my computer is turned on, the stereo turns on at a deafening volume (for more on this, see the section on development tools).

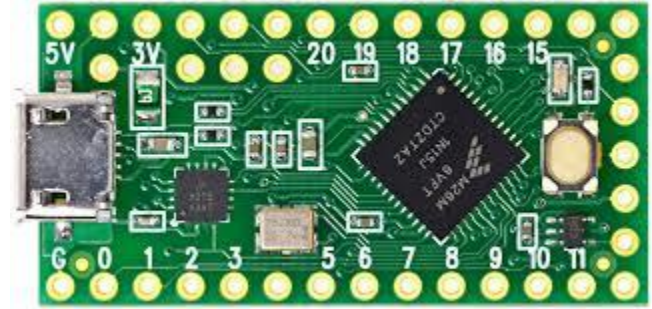

Microcontroller

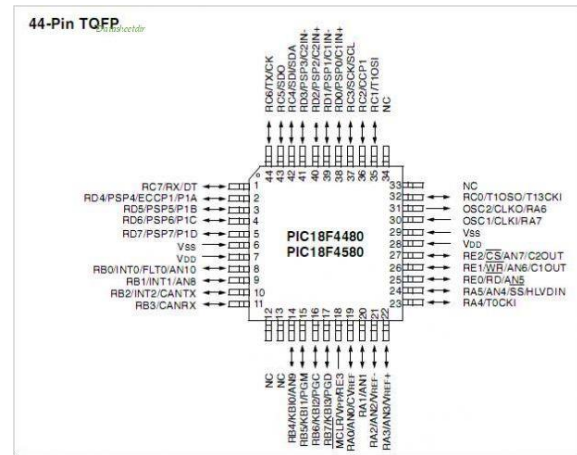

Pin Diagram Of Microcontroller

At one time, controllers were built exclusively from logic components, and were usually large, heavy boxes (before this, they were even bigger, more complex analog monstrosities). Later on, microprocessors were used and the entire controller could fit on a small circuit board. This is still common - you can find many [good] controllers powered by one of the many common microprocessors (including Zilog Z80, Intel 8088, Motorola 6809, and others). As the process of miniaturization continued, all of the components needed for a controller were built right onto one chip. A one chip computer, or microcontroller was born. A microcontroller is a highly integrated chip, which includes, on one chip, all or most of the parts needed for a controller.

Bluetooth Module HC-05

For the communication between mobile phone and microcontroller Bluetooth module is used, because the microcontroller can't do all this work itself. Hc-05 module is used for this purposes, which is low power

1.8 v operation, PIO control with integrated antenna, edge connector and is easy to use with Bluetooth SPP (serial port protocol). This is designed for transparent wireless serial connection setup. Serial port Bluetooth module have a Bluetooth 2.0+EDR (enhanced data rate), 3Mbps modulation with complete 2.4GHZ radio transceiver and baseband. Using Bluetooth profile and android platform architecture different type of Bluetooth applications can be developed.

SWITCHES: Switches are used to make and break the electrical circuit. There are so many types of switches, some are mechanically and some are electrically operated such as SPDT, SPST, DPST, DPDT etc. you can check push button interfacing article to use it in your microcontroller based project.

RELAY

A relay is an electrically operated switch. Many relays use an electromagnet to mechanically operate a switch, but other operating principles are also used, such as solid-state relays. Relays are used where it is necessary to control a circuit by a low-power signal (with complete electrical isolation between control and controlled circuits), or where several circuits must be controlled by one signal. The first relays were used in long distance telegraph circuits as amplifiers: they repeated the signal coming in from one circuit and re-transmitted it on another circuit. Relays were used extensively in telephone exchanges and early computers to perform logical operations.

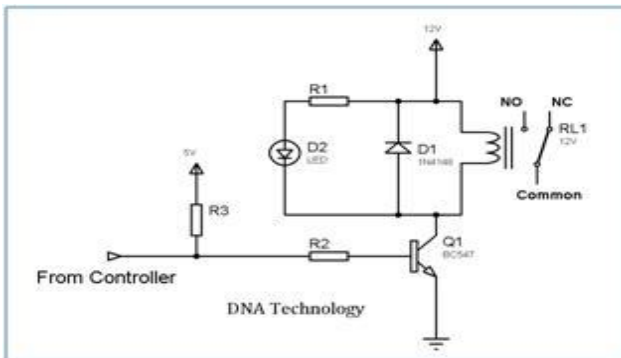

Circuit Diagram Of Relay Driver



relay kit

A type of relay that can handle the high power required to directly control an electric motor or other loads is called a contactor. Solid-state relays control power circuits with no moving parts, instead using a semiconductor device to perform switching.

Working:

A relay is an electrical switch that opens and closes under the control of another electrical circuit. In the original form, the switch is operated by an electromagnet to open or close one or many sets of contacts. It was invented by Joseph Henry in 1835. Because a relay is able to control an output circuit of higher power than the input circuit, it can be considered to be, in a broad sense, a form of an electrical amplifier.

MCP2551:High-Speed

CAN

Transceiver:

A CAN transceiver circuit is a circuit that can communicate with the CAN bus and extract data from it. Multiple electrical subsystems can connect to the CAN bus and each can communicate with the microcontroller or CAN chip connected, though not at the same time. This allows the microcontroller to analyze data from all of these units and respond accordingly to the data and which subsystems are priority. It's a message-based communication system between the microcontroller and all the electrical subsystems on the CAN bus.

A CAN bus stands for Controller Area Network bus. It is a type of communication hub in which many devices, or nodes, can be connected up to it. It is a message-based protocol, a type of multiplex electrical wiring system.

The CAN bus is used in many applications, the most common being in automobiles. Many cars are equipped with a CAN bus and exchange messages through this bus.

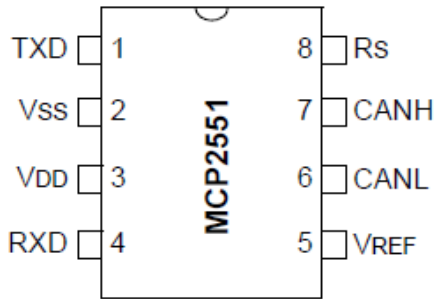

Pin Diagram of MCP 2551

The MCP2551 is a CAN transceiver chip. It is capable of reading data from a CAN bus and transmitting and receiving data from a microcontroller or CAN controller.

The Rx pin, pin 4, is the receiver pin. It receives the data from the CAN bus. It reflects the differential bus voltage between CANH and CANL. If the differential voltage is LOW, this corresponds to a dominant state. If the differential voltage is HIGH, this corresponds to a recessive state. So the Rx pin is able to receive data from the CAN bus so that interpretation can be made.

The CANL, CAN LOW, pin, pin 6, is the pin that represents the low side of the CAN differential bus. It is connected to one of the inputs of the internal comparator inside the chip.

The CANH, CAN HIGH, pin, pin 7, is the pin that represents the high side of the CAN differential bus. It is connected to the other input of the same internal comparator chip as the CANL pin. By both the CANH and CANL pins being connected to the comparator chip, the differential voltage between the 2 pins can be measured. If the differential voltage is 0, this represents a dominant state by the particular node the chip is reading from. If the differential voltage is 1, this represents a recessive state.

The RS pin, pin 8, is the slope resistor input. This pins is used to select high-speed, slope-control, or standby mode based on the external biasing resistor.

RESULT

In this project we can turn ON OR OFF the multiple electronic device by using Android phone from any time and any where in our home

FINAL DESIGN

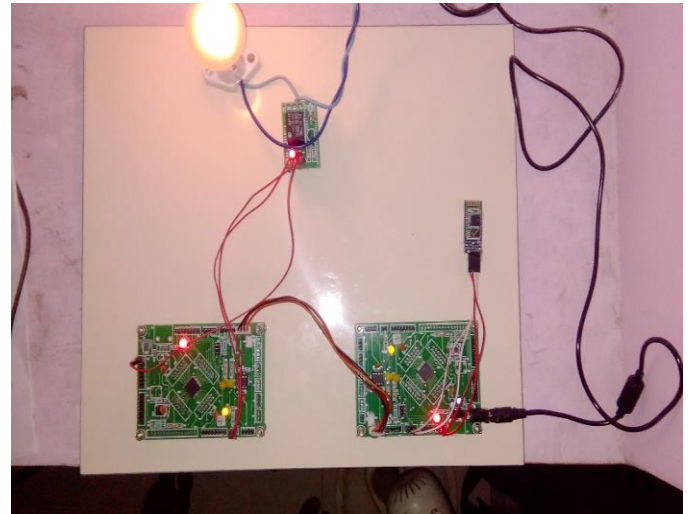

Conclusion:

The home automation system has been experimentally proven to work satisfactorily by connecting sample appliances to it and the appliances were successfully controlled from a wireless mobile device. The Bluetooth client was successfully tested on a multitude of different mobile phones from different manufacturers, thus proving its portability and wide compatibility. This project will not only provide convenience to the common man but will be a boon for the elderly and disabled.

Future Scope:

This project can be further developed by integrating it with the internet to monitor your home while sitting in a remote area. By doing this, one can keep an eye on his or her home through an internet connected to the user's mobile phone or PC or laptop. This will not only improve the security of your home in this modern day world but will also assist in conservation of energy like if you left any home

appliance switched on by mistake, then you can check the status of the appliance on the graphical interface made on your mobile and can switch it off using the internet connectivity

REFERENCES

[1] A. Al-Hammouri, A. Covitch, D. Rosas, M. Kose, W. S. Newman, and V. Liberatore. Compliant control and software agents for Internet robotics. In WORDS, 2003.

[2] Ahmad Al-Hammouri and Vincenzo Liberatore. Decentralized and dynamic bandwidth allocation in networked control systems. In 14th International Workshop on Parallel and Distributed Real-Time Systems (WPDRTS), 2006.

[3] H. Zheng and J. Boyce, "Packet coding schemes for MPEG video overinternet and wireless networks," in *Proc. IEEE Wireless Commun. NetworkingConf. (WCNC)*, 2000, vol. 1, pp. 191–195.

[4] Roger Brockett. Stochastic control. Course Notes, Harvard University, 1992.

[5] K. Chandy and L. Lamport. Distributed snapshots: Determining global state of distributed systems. *ACM Transactions on Computer Systems*, 3(1):63–75, February 1985.

[6] Richard C. Dorf and Robert H. Bishop. *Modern Control Systems*. Prentice-Hall, Upper Saddle River, NJ, 2001

[7] H. Ekstroem and R. Ludwig. The peak-hopper: A new end-to-end retransmission timer for reliable unicast transport. In *IEEE Infocom*, 2004.

Author Bibliography:



NTISH KUMAR

Pursuing bachelor of technology in electronics & Telecommunication engineering from Bharath University, Chennai, India
Email:knitish911@gmail.com



RAKESH RANJAN

Pursuing bachelor of technology in electronics & Telecommunication engineering from Bharath University, Chennai, India
Email:rkshranjan7200@gmail.com