

# Transformer Based 15 Level MLI for PVCELL Applications

S. Suri Babu & S.Rajsekhar

P.G Scholar, Department of EEE, ASR College of Engineering & Technology, JNTUK, A.P

Assistant Professor, Department of EEE, ASR College of Engineering & Technology, JNTUK, A.P

## Abstract:

*This study presents a novel topology for multilevel inverters so called cascaded transformer inverter (CTRSI). This topology consists of one DC source and several single-phase transformers. Each single-phase transformers generates three levels with four semiconductor switches and only two switches for all transformers alter the direction of single DC source. Whereas each single-phase transformers in conventional cascaded transformer multilevel inverter includes more switches. Hence, CTRSI has the advantage of a reduced number of components compared with conventional cascaded transformer multilevel inverter. Simulation results carried out by MATLAB/SIMULINK. The results show that the proposed inverter topology is able to reach high-quality output voltages. THD of output voltage is verified using FFT analysis tool*

**Keywords:** multilevel inverter; transformer; three phase; PWM

## 1. INTRODUCTION

Multilevel converters have become extremely popular in recent years and applications in some systems such as large motor drives, flexible AC transmission systems, power quality improvement devices and renewable energy converters [1–3]. Multilevel converters provide several features include large power conversion capability, better harmonic spectrum and low dv/dt stress on switches and loads, reduced electromagnetic interference (EMI), lower switching losses and smaller common mode voltage. The basic multilevel inverter topologies are diode clamped; flying capacitors (FCs); and cascaded H bridge with separate DC source. Although the three topologies provide voltage with high quality, their disadvantages limit their applications. The main disadvantage associated with the multilevel

configurations is the great number of power semiconductor switches needed.

The diode-clamped multilevel inverter uses capacitors in series to divide up the DC bus voltage into a set of voltage levels. Voltage unbalancing and the number of clamping diodes are the major difficulties of diode clamped multilevel inverter. In FC multilevel inverter that uses a ladder structure of capacitors and one DC source the control is complicated to support the voltage levels for each of the capacitors. For lower switching frequency, the large capacitors in size are required. The use of large number of capacitors is expensive and bulk. The cascade H-bridge multilevel inverter uses cascaded inverters with separate DC sources. The main disadvantage of H-bridge multilevel inverter is the need of separate DC sources for each of the H bridges. Many topologies of multilevel inverters using a reduced number of switches and gate-driver circuits are presented in recent years. A double FC multicell converter has been presented. The main advantages of the presented converter, in comparison with the FC multilevel, are the doubling of the rms value of the output voltage and the number of output voltage steps but some switches must operate at the peak of the output voltage and this topology needs a lot of number capacitors in high number of levels.

In other configurations of multilevel inverters have been proposed. The suggested topologies need fewer switches and gate driver circuits but they require multiple DC sources and some switches of suggested topologies in have high peak inverse voltage.

The number of isolated DC source is more for a cascaded multilevel inverter and this problem almost has been solved in FC and diode-clamped topologies but adjusting capacitors voltage also make the multilevel topology more complex. Hence, the control schemes become complicated as the number

of levels increases. In cascaded transformer multilevel topology is proposed. This topology has the advantage of having single-storage capacitor for all its cells.

The main disadvantage is that this topology has many switches. The present work focuses on a new multilevel inverter topology utilizing the single-phase low-frequency transformers to make a large number of output voltage levels with one DC source. The new topology is called cascaded transformer reduced switches inverter (CTRSI). CTRSI employs one single DC input power source, isolated single phase low-frequency transformers and semiconductor switches. The number of switching devices and DC voltage sources of the proposed inverter are reduced although single phase low-frequency transformers that have been added to inverter circuit. Simulation and experimental results verify the ability of the proposed inverter in voltage generating.

## 2 CASCADED TRANSFORMER

### H-BRIDGEMULTILEVEL INVERTER

Conventionally, the multilevel inverters are divided in three basic structures: The diode clamped (DC), FC inverter and cascaded H bridge inverter. The cascaded H-bridge inverter synthesis a desired voltage from several independent DC sources. This inverter can avoid extra clamping diodes or voltage balancing capacitors. The cascaded H-bridge inverter requires the least number of total main components. Recently cascaded transformer multilevel topologies with single DC source are proposed. Fig. 1 shows a single-phase topology of a cascaded transformer converter with single DC voltage source. The output voltages of basic units are cascaded through the secondary of the transformers. The input voltage of transformers is defined by switching functions of the basic units. Output voltage is sum of the transformers output voltages. The amplitude of the output voltage is determined by the input DC voltage source and turn ratio of the transformers.

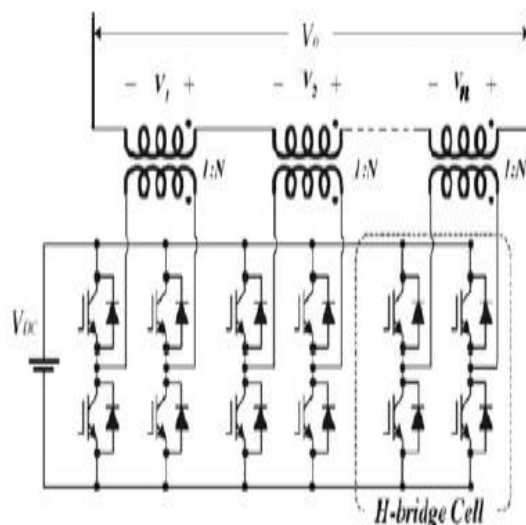

Fig 1. Circuit diagram of single phase cascaded transformer H-bridge multilevel inverter

## 3. CASCADED TRANSFORMER MULTILEVEL INVERTER

Multilevel inverters have become every day more popular, and they can achieve a high range of voltage and power and they have important advantages; high power quality, low total harmonic distortion (THD), reduced derivative voltages and low switching frequency. However, the multilevel inverters have drawbacks such as the large number of semiconductor switches and isolated DC supplies that must be balanced. The proposed topology utilizes the single DC source and a few number of switches in comparison with conventional multilevel inverters. The circuit diagram of the suggested topology is shown in Fig. 2. The CTRSI derives several output voltage levels by using a single DC voltage source at the input. However, single-phase low-frequency transformers are used in CTRSI. The main functions of the transformers are series connection, voltage transformation and isolation. Each single-phase transformers have three levels voltages in their input and output. An output phase voltage is obtained by summing the output voltages of transformers.

$$V_0 = V_{01} + V_{02} + \dots + V_{0n} \quad (1)$$

Where  $n$  is the number of cascaded transformers.

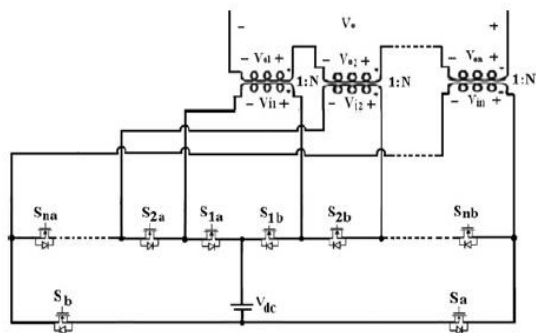

**Fig 2. Circuit topology of cascaded transformer inverter**

If all turn-ratio of transformers in Fig. 2 are equal to 1:N then the converter is known as uniform step symmetric multilevel inverter. The effective number of output voltage levels ( $m$ ) in CTRSI may be related to the number of transformers ( $n$ ) by

$$m = 2n + 1 \quad (2)$$

and the maximum output voltage of this  $n$  cascaded transformers is

$$V_{Omax} = nNV_{DC} \quad (3)$$

The number of switches is given by (4) or (5)

$$SW = 2n + 2 \quad (4)$$

$$SW = m + 1 \quad (5)$$

where  $SW$  is number of switches

#### 4. OPERATION OF CASCADED TRANSFORMER MULTILEVEL INVERTER

To introduce the operation of the proposed multilevel inverter in the generation of a desired output voltage waveform, a prototype seven-level CTRSI shown in Fig. 3 has been simulated using MATLAB/SIMULINK. If proper switching is used, then output voltage levels can be obtained between +3V<sub>dc</sub> and -3V<sub>dc</sub>. The maximum output voltage of this topology is 3V<sub>dc</sub>. Table 1 shows the value of the output voltage  $V_0$  in different modes of switching states. The input voltages of transformers by using this switching are shown in Fig. 3.

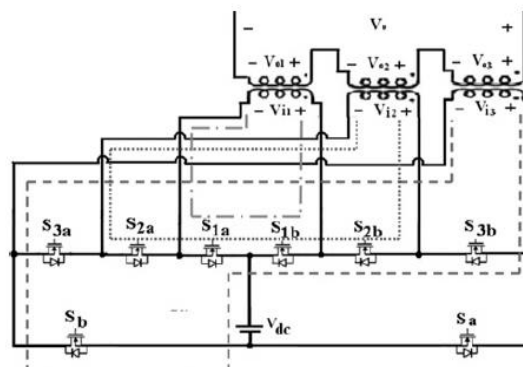

**Fig 3. Multi level CTRSI**

**Table 1** Values of  $V_0$  for state of switches

$V_0$	$S_a$	$S_b$	$S_{1a}$	$S_{2a}$	$S_{3a}$	$S_{1b}$	$S_{2b}$	$S_{3b}$
$V_{dc}$	off	on	on	on	off	on	on	on
$2V_{dc}$	off	on	on	off	on	on	on	on
$3V_{dc}$	off	on	off	on	on	on	on	on
0	off	off	on	on	on	on	on	on
$-V_{dc}$	on	off	on	on	on	on	on	off
$-2V_{dc}$	on	off	on	on	on	on	off	on
$-3V_{dc}$	on	off	on	on	on	off	on	on
undesirable	on	on	on	on	on	on	on	on
undesirable	off	on	on	on	on	off	off	off
undesirable	on	off	off	off	off	on	on	on

There are several modulation strategies for multilevel inverters and operation of them depends on modulation strategies. The modulation methods used in multilevel inverters can be classified according to switching frequency. In this paper, the fundamental frequency switching technique has been used. It is important to note that the calculation of optimal switching angles for different goals such as elimination of the selected harmonics and minimising THD are not the objective of this paper.

**5. SIMULATION RESULT**

The model for single source cascaded transformer 15 level multilevel inverter for three phase has been successfully modeled and tested using MATLAB/SIMULINK toolbox. The performance is evaluated using FFT simulation.

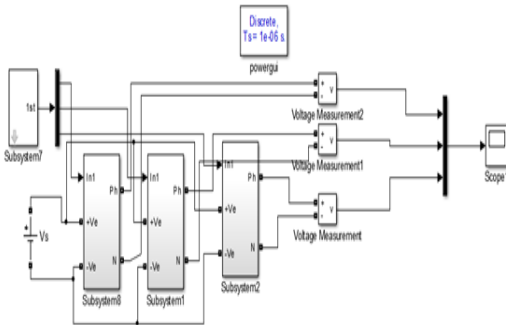

**Figure 1: Simulation model of cascaded transformer inverter**

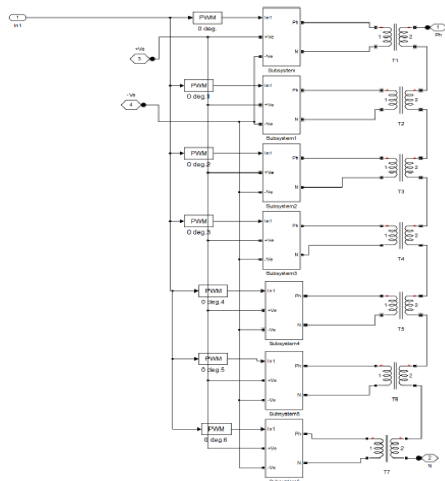

**Figure2: Simulation model of sub system**

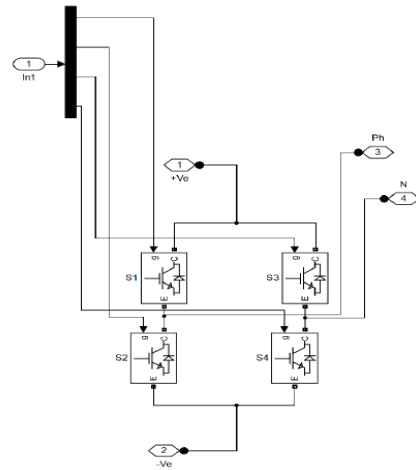

**Fig 3 Simulation Result of Single Cell Inverter**

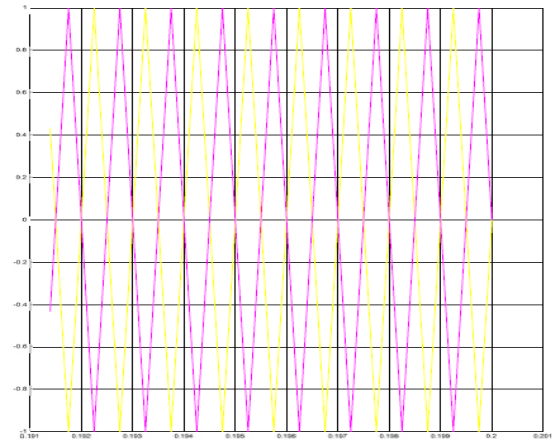

**Fig 4 Simulation Result of Output of Trigger Level**

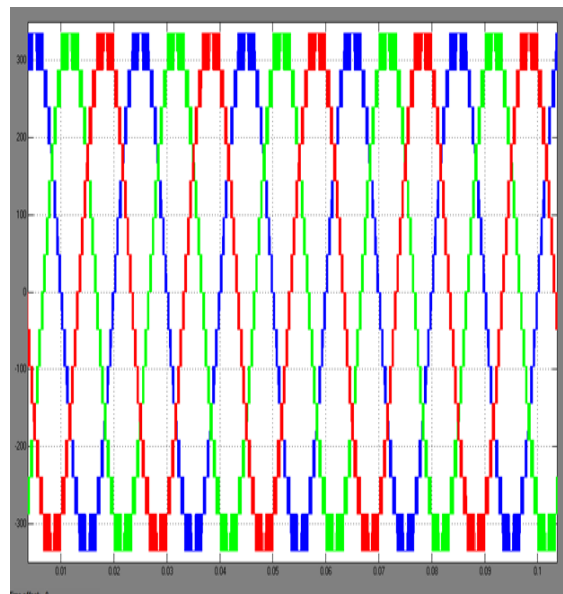

**Fig 5 output voltage of cascaded transformer 15 level multilevel inverter**

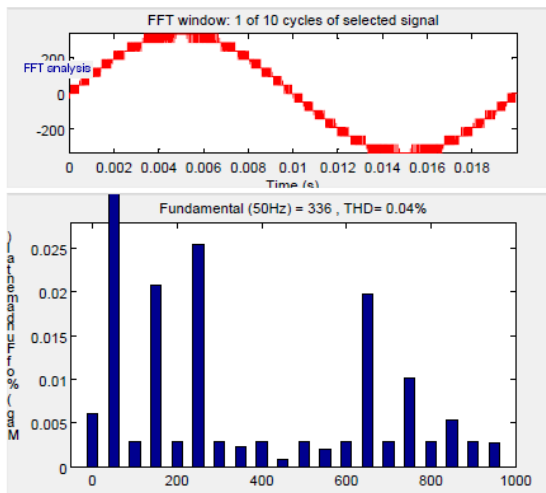

**Fig 6 THD Analysis of output voltage using FFT analysis tool**

## 6. CONCLUSION

In this paper, a novel topology has been presented for symmetrical multilevel inverter, which has reduced number of DC voltage sources and switches. Even though the use of transformers increases the design complexity and cost of the inverter, the proposed topology is simple and includes minimum number of components. The transformers can be used to isolation and voltage transformation. In the proposed topology, the PIV of all switches are equal with the  $V_{dc}$ . Simulation and experimental results show performance and feasibility of the suggested topology in voltage generating.

## 7. REFERENCES

[1] Panagis, P., Stergiopolos, F., Marabeas, P., Manios, S.: ‘Comparison of state of the art multilevel inverters’. Proc. Power Electronics Specialists Conf. PESC 2008, IEEE, 2008, pp. 4296–4301

[2] Meynard, T.A., Foch, H., Forest, F., et al.: ‘Multicell converters: derived topologies’, IEEE Trans. Ind. Electron., 2002, 49, (5), pp. 978–987

[3] Du, Z., Tolbert, L.M., Ozpineci, B., Chiasson, J.N.: ‘Fundamental frequency switching strategies of a seven-level hybrid cascaded H-bridge multilevel inverter’, IEEE Trans. Power Electron., 2009, 24, (1), pp. 25–33

[4] Corzine, K.A., Familant, Y.L.: ‘A new cascaded multilevel H-bridgedrive’, IEEE Trans. Power

Electron., 2002, 17, pp. 125–131

Zhiguo, P., Peng, F.Z.: ‘Harmonics optimization of the voltage balancing control for multilevel converter/inverter systems’. Proc. IEEE 39th Annual Industry Applications Conf., 3–7 October 2004, vol. 4, pp. 2194–2201

[5] Nabae, A., Takahashi, I., Akagi, H.: ‘A new neutral-point clamped PWM inverter’, IEEE Trans. Ind. Appl., 1981, IA-17, pp. 518–523

[6] Rodriguez, J., Lai, J.S., Peng, F.Z.: ‘Multilevel inverter: a survey of topologies, controls, and applications’, IEEE Trans. Ind. Electron., 2002, 49, (4), pp. 724–738

Hammond, P.: ‘A new approach to enhance power quality for medium voltage ac drives’, IEEE Trans. Ind. Appl., 1997, 33, pp. 202–208

[7] Cengelci, E., Sulistijo, S.U., Woom, B.O., Enjeti, P., Teodorescu, R., Blaabjerge, F.: ‘A new medium voltage PWM inverter topology for adjustable speed drives’. Proc. Conf. Rec. IEEE-IAS Annual Meeting, St. Louis, MO, October 1998, 1998, pp. 1416–1423

[8] Sadigh, A.K., Hosseini, S.H., Sabahi, M., Gharehpetian, G.B.: ‘Double flying capacitor multicell converter based on modified phase-shifted pulsewidth modulation’, IEEE Trans. Power Electron., 2010, 25, (6), pp. 1517–1526