



An Automated Green wall Management System

Anita Devi¹

Electronics and communication engineering Department, MVN University, Haryana, India
 EMAIL: anitagola235@gmail.com

Dr Rajeev Ratan²

Associate Professor, ECE Department MVN University, Haryana, India
 rajeevarora@mvneducation.com

Mr Alok Shrivastav³

Assistant Professor, ECE Department MVN University, Haryana, India
alok.srivastava@mvn.edu.in

Abstract

The main purpose of our work is to develop a system that automatically monitors and modifies environment parameters of plants, grown vertically, at particular angle in man-made stable eco system attached to walls of building. The designed system is fully sensor based and that can control everything without the human interference. Monitoring and control of various factors for plant growth play significant role in green wall production and management. To monitor the green wall environment parameters effectively, we need to design an automatic control system. There are various factors which affects plant growth. The most important factors that give quality and productivity to plant are temperature, humidity and light. A plant grower needs regular monitoring and modification of these environmental variables to better understand, how growth and yield is affected by each factor and how to manage them for maximal progress of plant. The optimal green wall climate adjustment not only enables us to achieve remarkable energy savings -especially during the winter but also to improve productivity. The main purpose of a green wall is to provide and maintain an environment for work efficiency as well as for good health in indoor areas. There are much research and system designs for environment monitor and control using sophisticated technology. The present control

system is designed using recent ATmega16 microcontroller due to some important features such as sleep mode, 10-bit ADC, wide input voltage range and also higher memory capacity.

Key Words: Environment parameters; Monitoring and controlling; Microcontroller; AVR; Moisture Sensors; Light Sensor and Temperature Sensor

Introduction

A green wall is a new and creative idea of growing greenery in an urban and indoor environment. Green walls consists special type of plant containers attached to wall structure at particular angle. Structures can be free standing or attached to wall. This advance greenery is eye catching, good looking and improves the look of once plain walls. Green walls are becoming more and more popular recently across the globe. These are widespread in Europe and also in other areas of higher temperatures. They can be made in the colder climates, with the proper plant variety. Living walls are also popular in the Singapore and Germany, where various buildings are being planned & designed to integrate vertical garden panels into their structure. [2]

The system presented here maintains moisture in soil and controls the microclimatic parameters of a green wall environment. The system consists of sensors, ATmega16 microcontroller, ADC and water pumps, cooler, artificial lights. The soil moisture sensors are deployed in the plant root zones. Aim of this system implementation is to demonstrate that the project can be used to save water, time and labour cost. [25]

When any of the environmental parameters cross a safety threshold value which we have to be maintained for plants growth, the sensors sense this change and send to controller at its input port through ADC. [8]

Microcontroller then performs the necessary actions by actuating relays until the strayed-out factors have been brought back to its required advantageous level. For real time display of data received from various sensors and status of the some other devices a Liquid crystal display (LCD) is also used. The system proposed here is an economical, low maintenance and portable for green wall applications, especially in developing countries. [8]



Fig No 1 Green wall Image

Existing System

In existing system automatic irrigation controlling process takes place fully based on 8051 microcontroller. Three soil sensors, Microcontroller 8051, ADC, LCD, relay and one water pump were devices used to design the system hardware. The controller monitors the soil moisture sensors and when more than two sensors sense the dryness condition then the microcontroller will switch on the motor automatically and when all the sensors are in wet condition then it will switch off motor. We analysed that system has some disadvantages.

- System has no light intensity controller.
- No temperature controller.
- We have no information of any parameter like humidity, light intensity, temperature etc. when we are far from green wall.
- System controls only one factor that is water so plant growth is not proper in living wall.
- Single water pump is in sufficient to irrigate whole green wall.

Proposed system

This project implementation primarily focuses on monitoring and controlling of Green wall environment parameters and automatically. The proposed system is based on various sensors such as moisture sensor, light sensor and temperature sensor for continuous monitoring the various parameters responsible for plant growth. The AVR microcontroller is used to perform necessary control actions as it has large no of advantages compared to 8051 microcontroller. It switches cooler, artificial lights and motors as per sensors status. The Proposed system not only controls irrigation but also controls the entire environmental variables which are necessary for the plant growth and yield such as light, temperature and water. Thus, this system removes

the drawbacks of the existing system mentioned in the previous section. The system uses three water pumps according to three sensors for proper irrigation of wall. It is easy to maintain, flexible and cost effective system.

Software Tools

- Code wizard (Automatic code generator V2.04.9a)

System Architecture

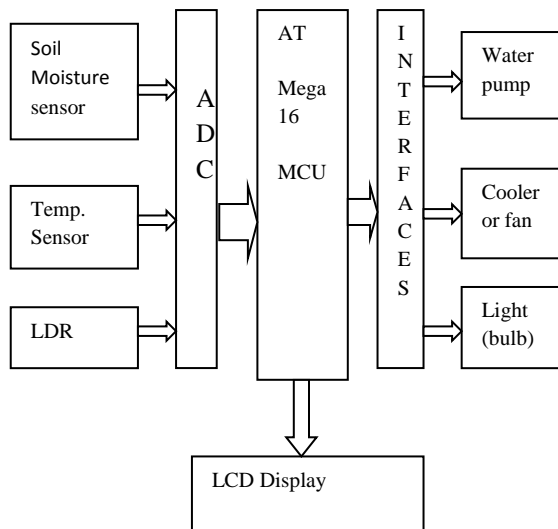

Fig no 2 system block diagram

The system model consists of various sensors, ATmega16 microcontroller, interfaces such as actuators, relays and AC devices. Our system objective is to prepare an embedded based circuit to continuous monitor and record values of soil moisture, light and temperature of the natural environment which are continuously modified to optimize them to get maximum plant growth and yield. Here in this system controlling process takes place automatically. Depending upon the

use of designed system, we set proper threshold level for every climatic parameter. If any of these parameters crosses a safety threshold level then microcontroller will perform the required action by employing relay until the particular parameter has been reached back to its optimum level.

2.1 Parts of the System

- Sensors (Data acquisition system)
 1. Temperature sensor
 2. Light sensor (LDR)
 3. Moisture sensor
- Analog to Digital Converter (ADC)
- Microcontroller (ATmega16)
- Liquid Crystal Display
- Relays
- AC Devices controlled
 1. Three water Pumps
 2. Cooler (simulated as a fan)
 3. Artificial Light (bulb)

System Design

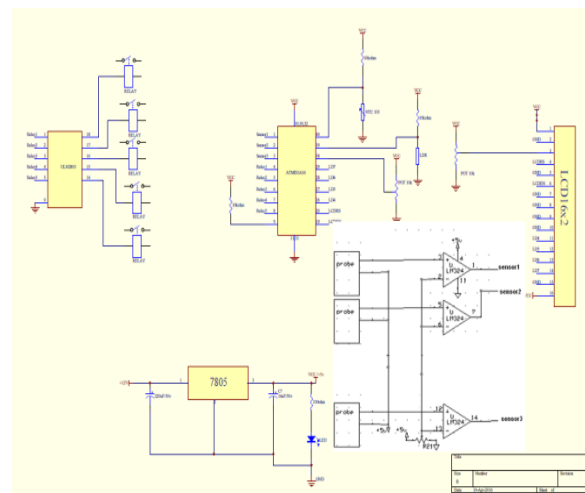

Fig no 3 System ckt diagram

Hardware Description

A. Sensor

Sensor is transducer which converts physical quantity into electrical signal. Sensors give analog signal which is proportional to that physical quantity. Sensors having high sensitivity can measure very small change. Sensitivity of a sensor indicates how much the output of a sensor changes when the measured quantity changes. Sensors used to measure environmental parameters are given below.

- **Temperature sensor**

The temperature sensor used in this project is thermistor. It is basically thermal resistor which changes its resistance with change in temperature. The sensor circuitry is not subjected to oxidation normally It is sealed. It can measure temperature accurately. It also has low self-heating property and does not exceed more than 0.1°C temperature rise in still air. Its operating temperature limit is from -55°C to 150°C.

- **Soil moisture sensor**

This moisture sensor consists of 2 copper conductors that are located at small distance from each other. For demonstration purpose, water pump is used and three soil moisture sensors for detecting soil moisture sensor. Both probes of soil-moisture-sensors are placed in soil. When no moisture is sensed by soil-moisture sensor in soil then the system turns on the motor or water pump until sensor senses the moisture in soil. Small potentiometer adjusts the Sense level. Its operating voltage ranges from 3.3V-5V.

- **Light sensor**

LDR is used in this system. It is a passive devices, converts this “light energy” into proportional electrical signal output. Light sensors are Photoelectric Devices so named “Photo Sensors” because these convert (photons) light energy into

the electricity (electrons). LDR is used for detecting light intensity.

B. Microcontroller

Present system uses the ATmega16 microcontroller to control whole system. It is based on AVR enhanced RISC architecture. It controls the whole system, receives input indirectly from sensors. It is a low-power CMOS 8-bit microcontroller. It operates on 5v DC supply provided by regulator IC 7805. By executing powerful instructions in a single clock cycle, the ATmega16 achieves outputs approaching 1 MIPS per MHz By executing powerful instructions in a single clock cycle, allowing the system designer to optimize power consumption versus processing speed. The AVR core combines a rich instruction set with 32 general purpose working registers. It provides the following features: 16K bytes of In-System Programmable Flash Program memory with Read-While-Write capabilities, 512 bytes EEPROM, 1K byte SRAM, 32 general purpose I/O lines. It has Six Sleep Modes: Idle, ADC Noise Reduction, Power-save, Power-down, Standby and Extended Standby.

C. Relay

Relay is an electrical device used as an electrical switch. It is operated by an electromagnet. It can control an output circuit having higher power than the circuit at input side. To operate fan, water pump and light, Current flows through relay driver (ULN2803). Relay consists an iron core and control coil is wrapped around it. The iron core interacts with the magnetic field around it, pulls the upper arm down by attracting it and allowing the power to go to the load by closing contacts. PIN 1-8 are the input with low voltage low current and 18-11 corresponding output with high voltage and high current. The high voltage is



configured on pin 10 (keeping in mind maximum output voltage of this IC). The current is also increased due to in-built Darlington Pair.

D. Liquid Crystal Display (LCD)

LCD is used to display the status of various sensors and other devices. It displays the temperature range, light intensity and moisture in soil. We need only 6 pins to interface an LCD. D4-D7 is the data pins connection and Enable and Register select are for LCD control pins. We are not using Read/Write (RW) Pin of the LCD, as we are only writing on the LCD so we have made it grounded permanently. Potentiometer RV1 is used to control the LCD contrast. The unwanted data pins of LCD i.e. D0-D3 are connected to ground.

E. AC Devices

AC devices produce movement when signal is applied to it such as fan or cooler, water pump and lights etc. These are used for the control of environment variables such as light, humidity, temperature etc. when any of environmental factors crosses its predefined threshold level. These find applications in various automatic control systems as industrial automation and in robotics.

Working

System is switched on by applying AC supply to the adapter having step down transformer. Adapter provides 12 volt supply to the regulator IC 7805 which gives 5v DC output to system as all components operate on 5V. Sensors output is given to ADC which provides digital signal at input port of microcontroller. Then controller generates necessary control signals to switch AC devices automatically.

The thermistor is used for sensing temperature. When temperature exceeds from a predefined level or critical level, then the system automatically switches on the fan and also displays information of all parameters (Temperature, soil sensor and Electrical appliance on/off position) on LCD. And when the temperature falls below in normal range or comes to the predefined level Fan turns off automatically. Moisture sensor is used for sensing moisture in soil. When moisture comes down from a defined level, controller turns on the water pumps automatically to maintain moisture level in soil and made off in presence of moisture. Similarly, LDR is used to show light intensity. When there is no light in green wall, colorful light is made on automatically and made off in presence of light.

The individual outputs from all these sensors are in the analog form. Sensed analog signal is converted into digital signal by ADC for further processing. Thus the digital values are given to the Microcontroller to indicate status of devices on LCD. The microcontroller will read the sensor periodically and updates the value of sensor. If any of the Green wall parameters exceeds the threshold value set by the user, necessary control action will takes place automatically. If the Green wall parameter falls below the threshold value, the controller will be turned off ac device.

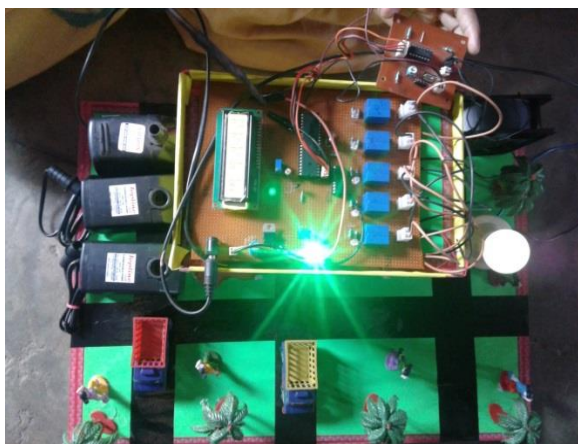

Fig no 4 Project image

Results and Discussions

Project automatically monitors and modifies three main factors- light, moisture, and temperature on which over all progress of any plant depends. Microcontroller ATmega16 controls the five number of AC devices - three water pumps, one bulb and one fan successfully according to status of sensors. Status of all sensors and AC devices can be easily seen from the display as per fig no 5.

- The fig no 5 shows that all the soil moisture sensors are in dryness condition, shown on LCD by alphabet 'D', lamp is off and temperature is 25⁰C. The LCD data shows that there is sufficient light so lamp is off and temperature is below threshold level ie.32⁰C so fan is also off.

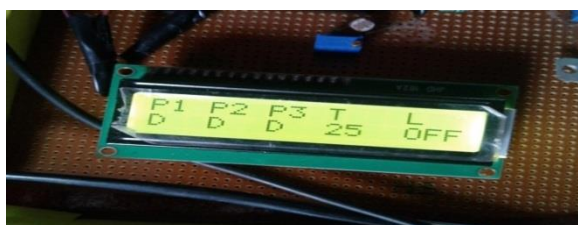

Fig no 5 Sensor and devices status.

- Now all soil moisture sensors are in wet condition after some time of motor starting, as shown in fig 6 by alphabet 'w'



Fig no 6 Soil sensor status in presence of water in soil.

- Readings are taken at room temperature of 27⁰ C, Tolerance= ± 0.2 V for soil moisture and ± 0.1 V for light sensor. Results are shown below using soil sensor by tables 1.

Table 1 Soil moisture sensor readings

Soil Condition	Transducer Optimum Range
Soil is dry	0V
Optimum level of soil moisture	1.9- 3.5V
Slurry soil	>3.5V

- Readings are taken at room temperature of 27⁰ C, Tolerance = ± 0.1 V for light sensor. Results are shown below using light sensor by tables 2.

Table 2 light sensor readings

Illumination Status	Transducer Optimum
OPTIMUM ILLUMINATION	0V-0.69V
DIM LIGHT	0.7V-2.5V
DARK	2.5V- 3V
NIGHT	3v-3.7v

Advantages of system

- Sensors used here have high sensitivity and are very easy to handle.
- Low cost system and provide maximum automation.
- Closed loop design avoids any chances of disturbing green wall environment.
- It is indicated to user for changes in actuator position thereby giving an option for the manual override.
- Low maintenance cost and low power consumption.
- This system is more compact and reliable compared to existing ones, hence it is easily portable.
- By making minor changes in ambient environmental parameters, system can be used for other plant species.
- Can be easily modified to improve the setup and add new features.
- Labour saving.
- It provides a user-friendly interface so have a greater acceptance to the

technologically unskilled workers.

- As per response of the sensors, the system adjusts the fans, heating, lighting and irrigation immediately, hence protects the green wall from damage.
- Malfunctioning of any single sensor will not affect whole system.
- Natural resource as water saved to a large extent.

Conclusions. A step-by-step approach to design the microcontroller based system for monitor and control of the three essential parameters for vertically grown plant growth, i.e. Soil moisture, light intensity and temperature, has been followed. The measurement shows that the system performance is accurate and quite reliable.

The designed system has successfully overcome the drawbacks of the previous system by reducing maintenance, complexity and the power consumption, at the same time providing very precisely management of the environment. The system has large no of advantages and easy to operate. Less amount of water is used due to controlled irrigation and it helps to save water and time. Use of multi sensors reduces quantity of dead plants and increases quality and productivity of plants. Well developed and good quality plants results a beautiful living green wall. Thus the system is efficient and compatible to change the environment.

Future scopes

- The system can be connected to the communication devices like cellular phones, modems, or satellite terminal for remote collection of the recorded data.
- Above discussed system has wired connection, made on the board.



Performance of this system can be improved with latest technology using short message service in the area of the wireless communication and GSM technology with the help of embedded technology.

- Fertilizers, insecticides, humidity sensor, sprayer and pesticides can be added in system to make it better management system applicable not only green wall but also in area of agriculture.
- The system performance can be made better in terms of the memory space, operating speed, instruction cycle period of the AVR microcontroller by using other controllers as PICs and PVRs. The quantity of channels can be increased by interfacing more number of sensors and which is possible only by using more advanced versions of microcontroller.
- The system can be improved with the use of data logger and graphical LCD panel showing the sensor data after a period of time.
- A speaking voice alarm or buzzer could be used for better performance of system.
- The device can perform better if power supply is given to ckt by the dc battery source to reduce requirement of main AC power.
- The Multi-controller system may be developed that can enable a slave controller along with its master controllers to automate multiple green walls simultaneously.
- The future is bright of green walls as these are in mind of city developers and could be very important tool to solve food, space, and water problems in future.
- In future, green walls will be best way to control the indoor areas pollution. Further if they will be implemented in all developed and developing countries, they will generate new jobs.

References:

- [1.] Anita Devi, "Green wall automation system" International Journal of Latest Trends in Engineering and Technology (IJLTET), page no.350-355, Vol. 5 Issue 4 July 2015 ISSN: 2278-621X
- [2.] J. Binabid, "Vertical Garden. The Study of Vertical Gardens and Their Benefits for Low-rise Buildings in Oderate and Hot Climates" (Master thesis, University of Southern California, 2010). ProQuest - Central to Research around the World.
- [3.] S. M. Xiong, L. M. Wang, X. Q. Qu and Y. Z. Zhan, "Application Research of WSN in Precise Agriculture Irrigation", International Conference on Environmental Science and Information Application Technology, ESIAT 2009, Vol. 2, pp. 297-300, F. Zhang, "Research on water-saving irrigation automatic control system based on internet of things", International Conference on Electric Information and Control Engineering (ICEICE), pp. 2541-2544, 2011.
- [4.] N. Ye and J. Liu, "Smart orchard soil moisture monitoring system based on wireless



communication technology", IEEE International Conference on Software Engineering and Service Sciences (ICSESS), pp. 600-603, 2010.

[5.] P. Yeonjeong and T. C. Harmon, "Environmental application of multisensor data fusion: Automatic soil salinity control", IEEE International Conference on Multisensor Fusion and Integration for Intelligent System (MFI), pp. 158-162, 2008

[6.] A. Benzekri and L. Refoufi, "Design and Implementation of a Microprocessor-Based Interrupt-Driven Control for an Irrigation System", IEEE International Conference on E-Learning in Industrial Electronics, pp. 68-73, 2006.

[7.] A. Benzekri, K. Meghriche and L. Refoufi, "PC-Based Automation of a Multi-Mode Control for an Irrigation System", International Symposium on Industrial Embedded Systems, pp. 310-315, 2007.

[8.] Purna Prakash Dondapati, "An Automated Multi Sensored Green House Management" International Journal of Technological Exploration and Learning (IJTEL) Volume 1 Issue 1 (August 2012) –Page no: 21-24.

[9.] Uday A. Waykole , "Greenhouse Automation System" 1st International Conference on Recent Trends in Engineering & Technology, Mar-2012, Special Issue of International Journal of electronics, Communication & Soft Computing Science & Engineering, ISSN: 2277-9477-Page no:161-166.

[10.] Sumit A. Khandelwal, "Automated Green House Management Using GMS Modem", International Journal of Computer Science and Information Technologies, Vol. 3 (1) , 2012, 3099 – 3102

[11.] Indu Gautam, "Innovative Gsm Bluetooth based Remote Controlled Embedded System for Irrigation" International Journal of Computer Applications (0975 – 888) Volume 47– No.13, June 2012, Page no: 1-7.

[12.] K. Rangan, Indian Institute of Technology Madras, Chennai, India, T. Vigneswaran, SRM University, Chennai, India " An Embedded Systems Approach to Monitor Green House" 978-1-4244- 9182-7/10/\$26.00 ©2010 IEEE, Page-61-65.

[13.] Kiran Sahu, Mrs. Susmita Ghosh Mazumdar " Digitally Greenhouse Monitoring and Controlling of System based on Embedded System " International Journal of Scientific & Engineering Research, Volume 3, Issue 1, January-2012 1 ISSN 2229-5518.

[14.] Rajeev G Vishwakarma, Vijay Choudhary Department of Computer Science, SVITS Indore, India " Wireless Solution for Irrigation in Agriculture" Proceedings of 2011 International Conference on Signal Processing, Communication, Computing and Networking Technologies (ICSCCN 2011).

[15.] Vandana Pandya, Deepali Shukla , Asst. Professor, Medicaps Institute of Technology & Management, Indore (M.P.), India " GSM Modem Based Data Acquisition System " International Journal Of Computational Engineering Research (ijceronline.com) Vol. 2 Issue.5.



- [16.] G.K. Banerjee, Rahul Singhal, Electrical engineering dept., College of Technology G B Pant University Pantnagar, India "Microcontroller based Polyhouse Automation Controller" 2010 International Symposium on Electronic System Design.
- [17.] B.Chiranjeevini Kumari, K.Rajasekar, BVCEC, India "Implementation of SMS based Heartbeat monitoring system using PSoC Microcontroller" IJECT Vol. 2, SP-1, Dec 2011 ISSN: 2230- 7109(Online) | ISSN: 2230-9543(Print).
- [18.] Andersson, K., Bakke, J. V., Bjorseth, O., Bornehag, C.-G., Clausen, G., Hongslo, J. K., et al. (1997). TVOC and Health in Non-industrial Indoor Environments. Denmark: Munksgaard.
- [19.] Baugman, A., & Arens, E. (1996). Indoor humidity and human health - Part I: literature review of human health effects of humidity-influenced indoor pollutants. Indoor environmental quality, 102, 193-211.
- [20.] Green over Grey. (2012). Gallery - green wall projects and living wall images. Retrieved January 2013, 28, from Green over Grey living walls and design:<http://greenovergrey.com/photo-gallery/photogallery.php>
- [21.] Norback, D., Michel, I., & Widstrom, J. (1990). Indoor air quality and personal factors related to sick building syndrome. Scandinavian Journal of Work, Environment & Health, Vol. 16, 121-128.
- [22.] Rossenfeld, C. (2004, August 1). Budding business. Commercial Property News, 18(14). Available at ebscohost.com.
- [23.] Monroe, L. K., Madsen, J. J., Garris, L. B., Suttell, R., Geneser, E. A., & Easton, S. (2004). Green: Your questions answered. Buildings, 98(5), 28-44.
- [24.] Ries, R. and Bilec, M. M. (2006). The economic benefits of green buildings: A comprehensive case study. The Engineering Economist, 51(3), 259-295.
- [25.] D. Kuchekar, R. A. Pagare, Android Based Water Deployment System for Irrigation using WSN & GSM module. International Journal of Science and Research (IJSR) ISSN, 2319-7064, Volume 4 Issue 7, July 2015