“Voice Based Home Appliances Control System”

Miss. Dhamdhare Nayan Anil; Miss Kharwade Varsha Balasaheb; Miss. Kamble Poonam Babu & Prof.A.P Gargade

Mail_id: nayandhamdhare8249@gmail.com

Mail_id: varshakharwade106@gmail.com

Mail_id: kamblepoonam55@gmail.com

Government College Of Engineering And Research, Awasari, Khurd Department of Electronics and Telecommunication engineering, Awasri, Khurd Pune-412405.

Abstract: *The key objective of our system design is to provide easy means for normal, handicapped and old age persons to control and operate home appliances. Since home automation is gaining popularity day by day in today's world, we require a system which is affordable and simple to implement. Both these qualities are present in our project which has the capability to replace existing technologies. Practical voice recognition kit is utilized in order to store and recognize the user's voice. Moreover, this project also helps in efficient use of the electricity which is an important constraint in day to day life.*

Keywords: ARM controller (LPC 2148); Voice Recognition; ARM code vision; HM2007 Voice Recognition Module.

I. INTRODUCTION

Today world is a global hub due to advancements in technology. Inventions and evolution in technology has made this possible. Home automation has an important role in people's life when it comes to their standard of living as it provides convenient and hassle free environment. We require the intelligence of a microcontroller to control the devices and home appliances. There are various existing technologies available for similar purposes but their cost and complexity is major disadvantage. In this project, we have designed an affordable and simple to use system that takes the input from the voice recognition module and uses the microcontroller's intelligence to operate different devices.

II. PROPOSED SYSTEM

Here in our project, we have used ARM Microcontroller along with voice recognition module kit HM2007 [1]. The performance of ARM is best when interfaced with voice recognition technology. HM2007 is the cheapest and yet efficient voice recognition technology. Minimum number of

components is used for this project. First the user has to store the commands and then speak again so that the HM2007 can recognize that particular command to operate accordingly. Fig 1 shows the complete connections for the proposed system. Software used for programming of microcontroller is CodeVision ARM and interfacing was done using USBasp.

Advantages Of Proposed System:

- 1) No need to directly interact with switch.
- 2) Time saver.
- 3) Reduced Human Effort.
- 4) Fully Electrical Isolation.

Applications Of Proposed System:

- 1) Mall
- 2) Home
- 3) Offices
- 4) Colleges

A) HM2007



It is a practical voice recognition system that is easy to train and implement. It means that the circuit will recognize the words when we train it by giving voice commands. The speech recognition system is a completely assembled and easy to use programmable speech recognition circuit. Programmable, in the sense that you train the words (or vocal utterances) you want the circuit to recognize. This board allows you to experiment with many facets of speech recognition technology. It has 8 bit data out which can be interfaced with any microcontroller for further development. Some of the interfacing applications which can be made are controlling home appliances, robotics movements, Speech Assisted technologies, Speech to text translation, and many more.

Features

- Self-contained stand alone speech recognition circuit
- User programmable
- Up to 20 word vocabulary of duration two seconds each
- Multi-lingual
- Non-volatile memory back up with 3V battery onboard. Will keep the speech recognition data in memory even after power off.
- Easily interfaced to control external circuits & appliances

Specifications

Parameter	Value	Note
Input Voltage	9 to 15 V DC	Use a commonly available 12V 500ma DC Adapter
Output Data	8 bits at 5V Logic Level	Any microcontroller like 8051, PIC or AVR can be interfaced to data port to interpret and implement specialized applications

Applications

There are several areas for application of voice recognition technology.

- Speech controlled appliances and toys
- Speech assisted computer games
- Speech assisted virtual reality
- Telephone assistance systems
- Voice recognition security
- Speech to speech translation

Speech recognition will become the method of choice for controlling appliances, toys, tools and computers. At its most basic level, speech controlled appliances and tools allow the user to perform parallel tasks (i.e. hands and eyes are busy elsewhere) while working with the tool or appliance. The heart of the circuit is the HM2007 speech recognition IC. The IC can recognize 20 words, each word a length of 1.92 seconds. The onboard 3V battery is used to store the RAM content even after power off so if you store the training words it remains after power off. Else you have to train the board again after each power up. Some people think 3V battery powers the board but it's not the case. You need to give external voltage to power the board.

How to use HM2007

The keypad and digital display are used to communicate with and program the HM2007 chip. The keypad is made up of 12 normally open momentary contact switches. When the



circuit is turned on, “00” is on the digital display, the red LED (READY) is lit and the circuit waits for a command.

Training Words for Recognition

Press “1” (display will show “01” and the LED will turn off) on the keypad, then press the TRAIN key (the LED will turn on) to place circuit in training mode, for word one. Say the target word into the onboard microphone (near LED) clearly. The circuit signals acceptance of the voice input by blinking the LED off then on. The word (or utterance) is now identified as the “01” word. If the LED did not flash, start over by pressing “1” and then “TRAIN” key.

You may continue training new words in the circuit. Press “2” then TRN to train the second word and so on. The circuit will accept and recognize up to 20 words (numbers 1 through 20). It is not necessary to train all word spaces. If you only require 10 target words that’s all you need to train.

Testing Recognition:

Repeat a trained word into the microphone. The number of the word should be displayed on the digital display. For instance, if the word “directory” was trained as word number 20, saying the word “directory” into the microphone will cause the number 20 to be displayed.

Error Codes:

The chip provides the following error codes.

55 = word to long

66 = word to short

77 = no match

Clearing Memory

To erase all words in memory press “99” and then “CLR”. The numbers will quickly scroll by on the digital display as the memory is erased.

Changing & Erasing Words

Trained words can easily be changed by overwriting the original word. For instances suppose word six was the word “Capital” and you want to change it to the word “State”. Simply retrain the word space by pressing “6” then the TRAIN key and saying the word “State” into the microphone. If one wishes to erase the word without replacing it with another word press the word number (in this case six) then press the CLR key. Word six is now erased.

B) LPC2148 Controller

LPC 2148 microcontrollers are based on a 16-bit/32-bit ARM7TDMI-S CPU with real-time emulation and embedded trace support, that combine the microcontroller with embedded high-speed flash memory ranging from 32 kb to 512 kb. A 128-bit wide memory interface and unique accelerator architecture enable 32-bit code execution at the maximum clock rate. For critical code size applications, the alternative 16-bit Thumb mode reduces code by more than 30 percentages with minimal performance penalty. In-System Programming/In-Application Programming via on-chip boot Loader software. Single flash sector or full chip erase in 400 ms and programming of 256 B in 1 ms. Embedded Trace interfaces offer real-time debugging with the on-chip Real Monitor software and high-speed tracing of instruction execution. USB 2.0 Full-speed compliant device controller with 2 kb of endpoint RAM.

In addition, the LPC2148 provides 8 kb of on-chip Random Access Memory accessible to USB by Direct Memory Access. One or two 10-bit ADCs provide a total of 6/14 Analog inputs, with conversion times as low as 2.44 ms per channel. Single 10-bit DAC provides variable analog output. Two 32-bit timers/external event counters (with four capture and four compare Channels each), Pulse Width Modulation unit (six outputs) and watchdog .Low power Real-Time Clock with the Independent power and 32 kHz clock input. The LPC 2148 incorporate a 32 kb, 64 kb, 128 kb, 256 kb and 512 kb flash memory system respectively. This memory may be used for both code and data storage. Programming of the flash memory may be accomplished in several ways. It may be programmed In System via the serial port. The application program may also erase and/or program the flash while the application is running, allowing a great degree of flexibility for data storage field firmware upgrades, etc. Due to the architectural solution chosen for an

on-chip boot loader, flash memory available for user's code on LPC 2148 is 32 kb, 64 kb, 128 kb, 256 kb and 500 kb respectively.

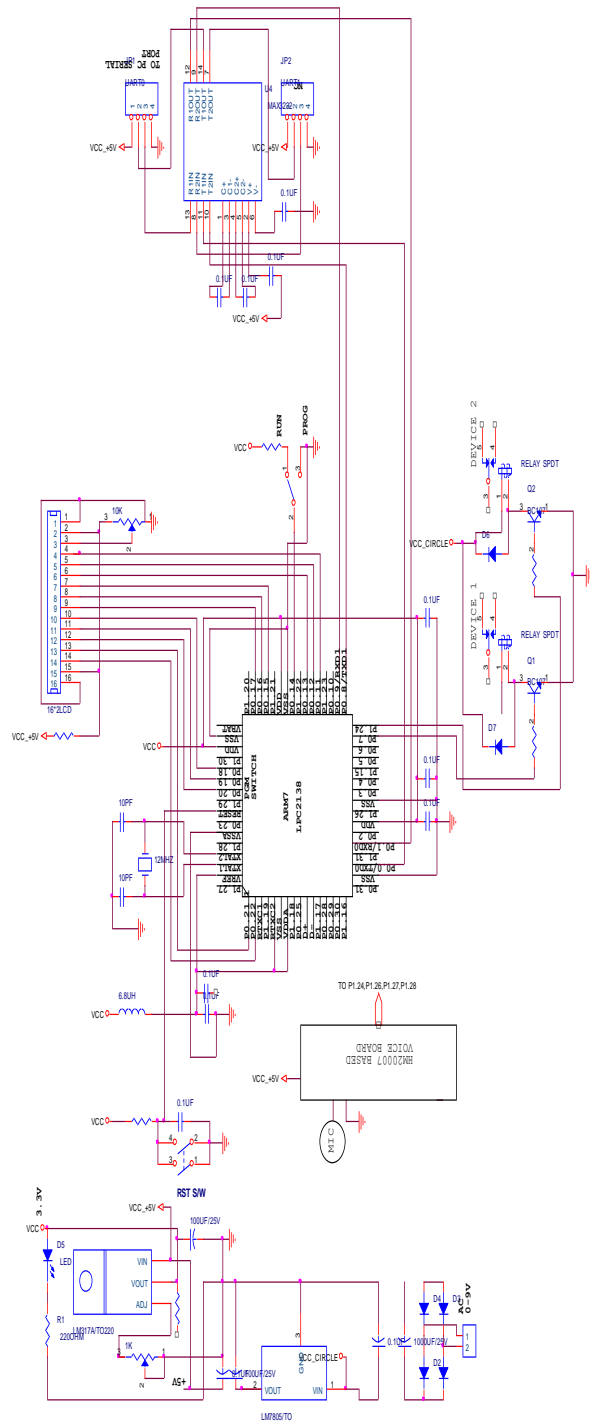

Fig. 1. Circuitry of complete system

III. WORKING OF THE SYSTEM

Firstly, 230V AC supply is converted to 5V DC using 12V step down transformer, Round bridge rectifier, smoothing circuit and LM7805 Voltage regulator. The working principle of speech recognition comprises of the fact that command given by any person generates vibrations or disturbances called as sound pulses. These analog waveforms are converted to digital form and decoded to appropriate commands including words and sentences. Initially, train the voice recognition module HM2007 with the suitable commands and say the commands after that. The commands will be stored in binary form and fed to ARM microcontroller through 8 bit data bus using latch IC. The microcontroller operates according to the program fed into it. One Port is used to take input from voice recognition module and another Port is used to control output devices. According to the program fed, microcontroller will respond to the instructions and will turn on/off the devices as and when required.

IV. RESULT

The voice recognition system was first tested in a quiet room with one user. All commands were correctly recognized by the system. Next we tested it with a different user on whom the system was not trained. About 5% errors occurred here, for example words like “accept” were recognized as “except”. This was because the recognizer heard a different pronunciation. Although, if the person had spoken the command multiple times the recognizer had sufficient examples to properly determine what pronunciation the person spoke. Then we tested the project in a noisy room by turning on some music in that room. When the sound was light there was no problem in correctly recognizing the words but when we increased the volume the recognizer found it difficult to recognize the user's voice and often took commands from what it heard in the song.



With the knowledge of operation of the system was tested step by step to the transistor output and the load was connected across the collector terminal of the transistor.

V. CONCLUSION

The prototype of system which is used for controlling devices through human voice is proposed and implemented and several changes can be done in this to suite different applications and scenarios. Following learning's were provided by this project: Speech recognition module operation, Interfacing Speech recognition module to Microcontroller and Relay working principle.

REFERENCES

[1] <http://www.sunrom.com/p/speech-recognition-system-hm2007>

[2] Voice Controlled Electrical Appliances International Journal of Electrical Electronics & Computer Science Engineering Volume 1, Issue 1 (February 2014), ISSN: 2348 2273

[3]Automotive embedded system handbook, industrial information technology series by

- a) Nicolas Navet
- b) Francoise simonot-lion

[4]E. A. Lee and S. A. Seshia,Introduction to Embedded Systems - A Cyber-Physical Systems Approach, LeeSeshia.org, 2011.

- 1) Embedded Systems Design
By Steve Heath