

Performance Evaluation of Advanced Three-Level AC– DC Converter Fed Induction Machine Drive

P. Vijay Ravi ; T.Srinivasa Rao & K. Durga Rao

¹M-Tech Student Scholar ; ²Associate Professor; ³Assistant Professor

Department of Electrical & Electronics Engineering, Avanathi Institute of Engineering and Technology, Makavarapalem, Visakhapatnam.

Abstract- *The topology of this converter is derived by combining a boost circuit and a forward circuit in one power stage. To improve the performance of the ac–dc converter (i.e., good power factor correction, low total harmonic distortion (THD) and low dc bus voltage), two bulk storage capacitors are adopted. Its excellent line regulation capability makes the converter suitable for universal input application. The operation of the converter is discussed in the project and its various modes of operation are explained in detail. Two independent controllers are majorly used to operate the converter namely an input controller that performs power factor correction and regulates the dc bus and an output controller that regulates the output voltage. They consist of an ac–dc boost pre regulator converter that shapes the input current and an isolated dc–dc full-bridge converter that converts the pre regulator output into the required dc voltage. Research on the topic of higher power ac–dc single-stage full-bridge converters, however, has proved to be more challenging, and thus, there have been much fewer publications. They use passive elements such as inductors and capacitors to filter low frequency input current harmonics and make the input current more sinusoidal. Two stage converters, however, require two separate switch-mode converters (each with its own controller), and thus, can be expensive. Moreover, they have poor efficiency when operating under light-load conditions as there are two converter stages that are operating each with its own set of fixed losses while a small amount of power is actually transferred to the load. The converter is designed by using Induction Drive System for Irrigation Applications Matlab/Simulink software.*

Index Terms— Induction Drive; three-level converters; Single-stage power factor correction (SSPFC); AC–DC power conversion

I. INTRODUCTION

Recently, developments in power electronics and semiconductor technology have led improvements in power electronic systems. Pulse Width Modulation variable speed drives are increasingly applied in many new industrial applications that require superior performance. Hence, different circuit configurations namely inverters have become popular and considerable interest by researcher are given on them. Variable voltage and frequency supply to A.C drives is invariably obtained from a three-phase voltage source inverter. To overcome the limited semiconductor voltage and current ratings, some kind of series and/or parallel connection will be necessary. Due to their ability to synthesize waveforms with a better harmonic spectrum and attain higher voltages, multi-level inverters are receiving increasing attention in the past few years. THE ac–dc power supplies with transformer isolation are typically implemented with some sort of input power factor correction (PFC) to comply with harmonic standards such as IEC 1000-3-2 [1],[2].

With the rapid rise in the use of electrical equipment in recent years, power converter manufactures are being pressed by regulatory to implement some form of PFC in their products. High power factor and low input current harmonics are more and more becoming mandatory performance criteria for power converters. Although it is possible to satisfy by adding passive filter elements to the traditional passive diode rectifiers/LC filter input combination. The result of this converter is very bulky and heavy due to the size of the low frequency inductors and capacitors. Active power factor correction techniques have been used in AC-DC converter to improve power factor and reduce the harmonics. Active power factor correction can be classified into two stage scheme. Two stages PFC contain two independent power stages in cascade with PFC stage and DC-DC regulator[3].

In this paper the drawbacks of the previously proposed single stage and two stage converters are minimized and finally a new single stage AC-DC converter is proposed. The paper introduces newly developed converter along with

its operating principles, various modes of operation and finally its features, design aspects.

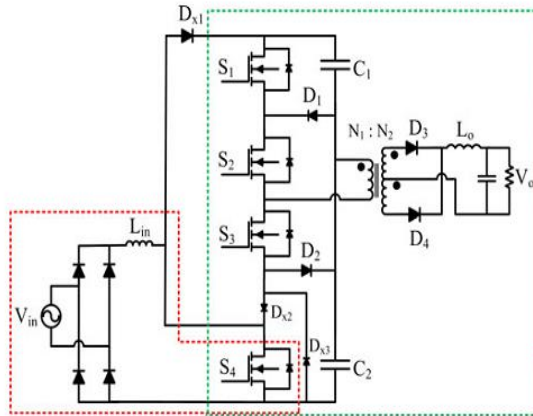

Fig.1. Proposed single-stage three-level converter.

The total efficiency of the two stages is lower because the total power has to be processed twice with two cascade power stage. Cost of the circuit is increase several schemes have developed to combine stage into one stage [4]. This paper introduces the new converter is interfaced to induction machine drive to check the performance of the drive characteristics and explains along with its basic operating principles.

II. OPERATION OF THE PROPOSED CONVERTER

The Fig. 1, shown above is the proposed converter which integrates the operation of an ac–dc boost PFC converter into a three-level dc–dc converter. An input diode bridge, boost Inductor L_{in} , boost diode D_{x1} , and switch S_4 , which is shared by the multilevel dc–dc section are the major components of the ac–dc boost section. When S_4 is off, it means that no more energy can be captured by the boost inductor. Here the input current flowing to the midpoint of capacitors C_1 and C_2 is prevented by the diode D_{x2} and the conduction of diode D_{x1} helps to transfer the energy stored in the boost inductor L_{in} to the dc bus capacitor. Diode D_{x2} is being bypassed by Diode D_{x3} and makes a path for circulating current. It is operated with two independent controllers although being a single converter. To regulate the voltage across the primary side dc-bus capacitors by sending appropriate gating signals to S_4 and to perform PFC one of the controller is used[5],[6].

To regulate the output voltage by sending appropriate gating signals to S_1 to S_4 the other controller is used. The main important aspect which is to be noted here is that the control of the input section is decoupled from the control of the dc–dc section and thus can be designed separately., Here on the basis of S_4 , the gating signal of S_1 is depended, which is the

output of the input controller; and the generation of this signal is discussed in detail later in this paper. Since the switches S_2 and S_3 are each ON for half a switching cycle, but are never ON at the same time so the generation of gating signals is easier for them. Here Fig. 2 shows the typical converter waveforms and Fig. 3 shows equivalent circuit diagrams that show the converter’s modes of operation with the diode rectifier bridge output replaced by a rectified sinusoidal source. As the switching frequency is higher than the input line frequency, it is assumed that the supply voltage is constant within a switching cycle. Although there is no reason why the input current cannot be made to be continuous so it is also assumed that the input current is discontinuous, if this is what is desired[7]. The converter has the following modes of operation:

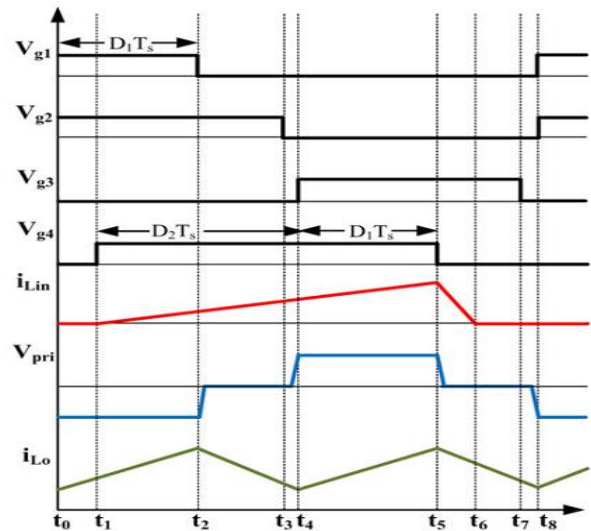
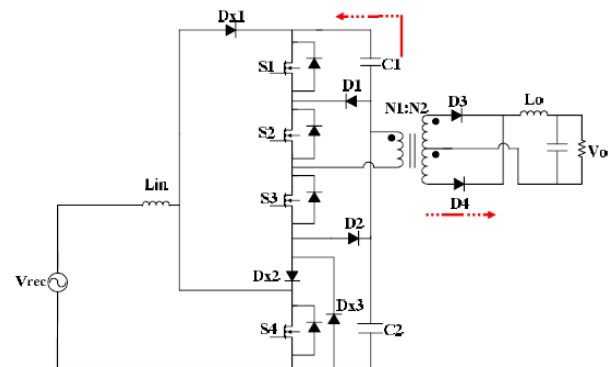

Fig. 2. Typical waveforms describing the modes of operation.

1) Mode 1 ($t_0 \leq t < t_1$):



During this mode, the output load is energized by the discharge of dc-bus capacitor C_1 by turn ON of switches

S_1 and S_2 . The positive voltage on the output side of transformer is given across L_o which makes current rising.

2) Mode 2 ($t_1 \leq t \leq t_2$): During this mode, the output load is energized by the discharge of dc-bus capacitor C_1 by making S_1 and S_2 still Turn ON and S_3 turns ON and also the output voltage of the diode bridge rectifier is given across the input inductor L_{in} thereby inductor current rising.

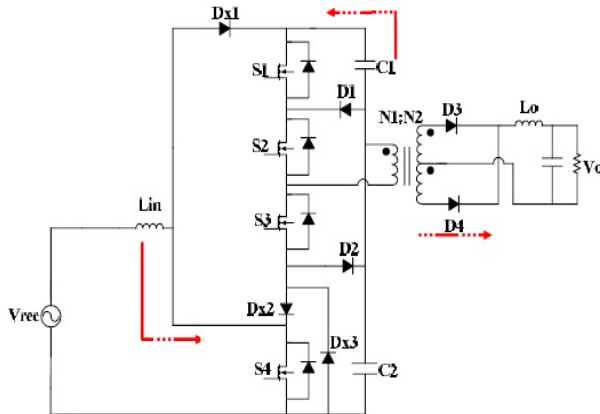

3) Mode3 ($t_2 \leq t \leq t_3$): In this mode, the switches S_1 and S_2 are still Turn ON and S_3 turns ON. The output load is energized by discharging of dc-bus capacitor C_1 . The output voltage of diode bridge rectifier is applied across input inductor L_{in} in order to make the inductor current which raises voltage applied across input inductor L_{in} thereby inductor current rising.

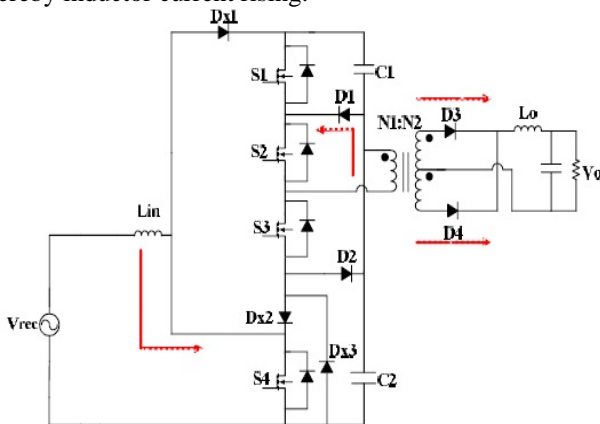

4) Mode 4 ($t_3 \leq t \leq t_4$): During this mode, S_1 and S_2 are OFF and S_4 is ON. The capacitor C_2 is being charged by the current in the primary of the transformer through the body diode of S_3 and D_{x3} .

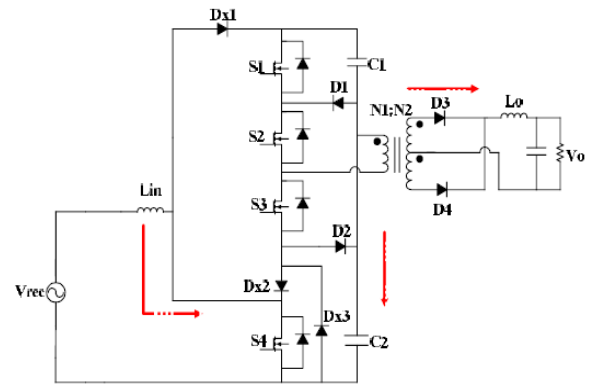

5) Mode 5 ($t_4 \leq t \leq t_5$): In this mode, S_3 and S_4 are ON. Energy flows into the load from capacitor C_2 while the current flowing through input inductor L_{in} continues to rise.

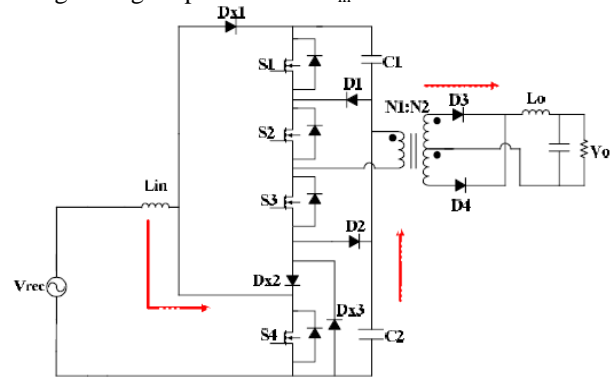

6) Mode 6 ($t_5 \leq t \leq t_6$): During this mode, S_4 turns off. The diode D_{x1} conducts current in input conductor to charge the capacitors C_1 and C_2 . Here S_3 and D_2 conducts current in the transformer primary winding. This mode ends when the inductor current reaches zero. The load inductor current freewheels in the secondary of the transformer in this mode.

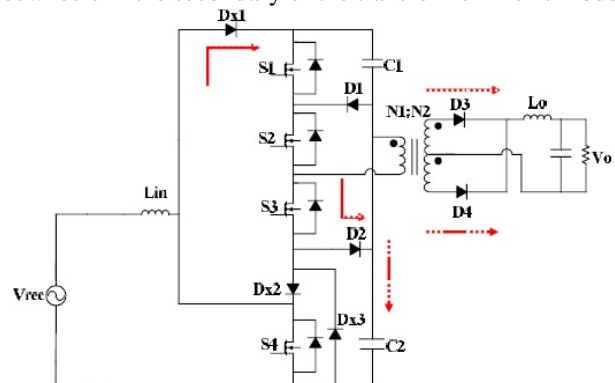

7) Mode 7 ($t_6 \leq t \leq t_7$): In this mode, the load inductor current freewheels in the secondary of the transformer. This mode ends when the switches S_3 turns off.

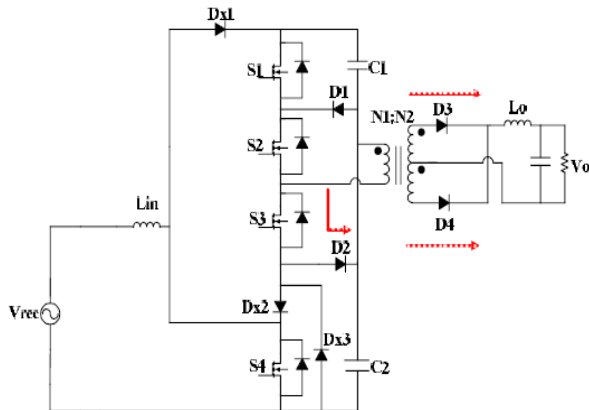

8) Mode 8 ($t_7 \leq t \leq t_8$): During this mode, S_3 is OFF and the capacitor C_1 charges through the current in the primary of the transformer through the body diodes of S_1 and S_2 . Finally, converter reenters Mode 1.

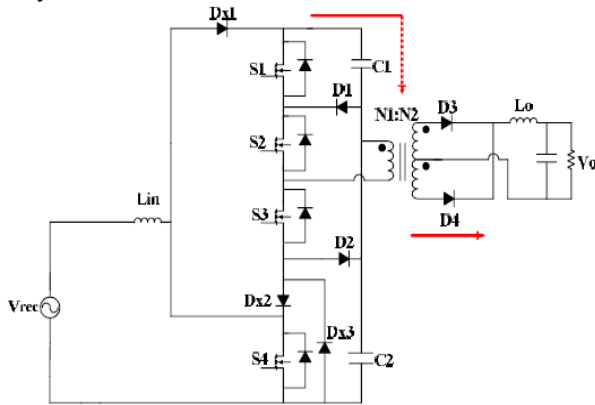

The Fig.4 shows the simplified schematic of the power converter and the respective controllers. Since the Cross over frequencies of the two loops is very different the decoupling of the input controller and output controller can occur. The input power factor correction and conversion of input ac into an intermediate dc-bus voltage due to the cross over frequency of the input controller, intermediate dc-bus voltage (voltage across the two primary side dc-bus capacitors), is much lower than that of the output controller, which converts the intermediate dc-bus voltage into the desired output voltage. It is possible to consider the design of one controller to be separate from that of the other, since the two crossover frequencies are far apart [8],[9].

The standard designs for a dc–dc full-bridge converter controller and an ac–dc boost converter controller can be used, since the two controllers are decoupled. The simple diagram of the controller scheme that has two elements of control is shown in the Fig. 4. By controlling the gating signals of S_1 to

S_4 through controlling duty cycle of D_1 the control of dc–dc conversion of the dc-bus voltage to the desired output voltage can be done and this will be the primary aspect to be noted. The secondary aspect which to be noted is to control duty cycle of the switch S_4 to regulate the dc-bus voltage and to perform input power factor correction. This can be done by controlling D_2 and then adding duty cycle of D_2 to D_1 (where D_1 and D_2 are defined in Fig. 2); thus S_4 performs majorly two tasks; one part (D_1) participate to control output voltage and another part (D_2) to regulate dc-bus voltage.

III.CONVERTER FEATURES

The proposed converter has the following features:

A) Reduced cost compared to two-stage converters:

The converter proposed in this paper may seem expensive but in practical terms it is much cheaper when compared to a conventional two-stage converter. The cost of the converter is low because replacing a switch and its associated gate drive circuitry with four diodes reduces cost considerably even though the component count seems to be increased and this is more real if the diodes are ordered in bulk numbers.

B) Better performance than a single-stage converter:

When compared to a single-stage single-controller, this single-stage converter can operate with a better input power factor for universal input line applications because it does have a dedicated controller for its input section that can regulate the dc-bus voltage and perform PFC. The converter can be made to operate with better efficiency and with less output ripple due to the presence of a second controller as each section can be made to operate in an optimal manner of the converter.

C) Improved Light-Load Efficiency:

In order to have a conventional dc-bus voltage of 400 V the proposed converter can be designed. Since the converter is a multilevel converter, a 400 V dc bus means that each switch will be exposed to a maximum voltage of 200 V. So by having 200 V across a MOSFET device instead of 400 V (since it is with the case with two-level converters) results in a 75% reduction in turn on losses when the converter is operating under light-load conditions and there is an insufficient amount to current available to discharge the switch output capacitances before the switches are turned on.

D) Increased Design Flexibility:

The proposed converter can be operated with standard dc-bus voltage (400 V), high dc-bus voltage (800 V), or any dc-bus voltage $400 V < V_{bus} < 800 V$ since the converter is a multi-level converter. While operating with high dc-bus voltage or with standard dc bus voltage the advantages are more often. The fact there is flexibility in the level that the dc-bus voltage is set means that there is considerable flexibility in the design of the converter. The design of the converter for other factors such as efficiency profile and cost (i.e. cost of switches based on voltage rating considerations and availability) can be optimized as per the designer's options. The design of the three-level converter to be much simpler than that of a single-stage two-level converter or that of a single-controller three-level single stage converter as the dc-bus voltage can be fixed to a desired level that is considered appropriate can be made flexibly which is to be noted. It also has the advantage of lower heavy-load efficiency because of increased conduction losses as switch S4 must conduct both the input current and the full-bridge current which is an additional advantage over the aforementioned advantages over the conventional two-stage converter, which is to be noted. Hence various factors which include lower cost and improved light-load efficiency versus heavy-load efficiency are to be considered when determining whether to use the proposed converter versus a conventional two stage converter[10].

IV. MATLAB/SIMULINK RESULTS

Case i) Single phase single stage power factor corrected converter for three level

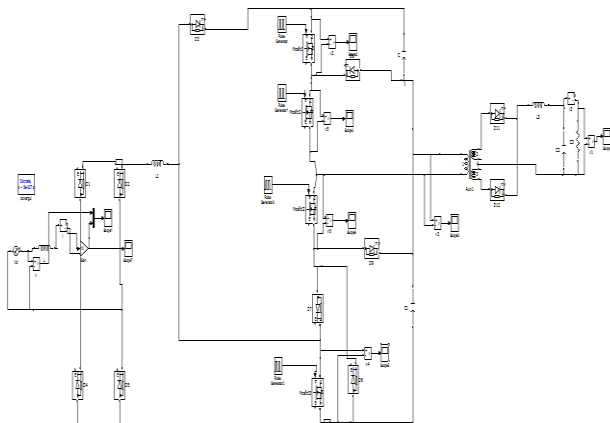

Fig.5: Matlab/Simulink Model of Single-Stage Three-Level Converter using Matlab/Simulink Software Package.

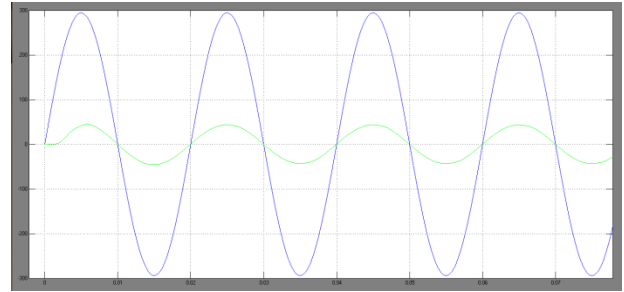

Fig.6: Input Current and Voltage Wave Form

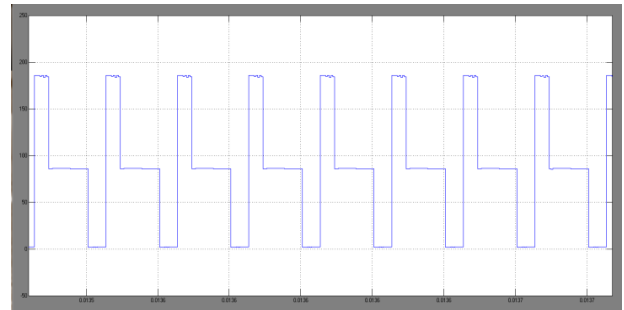

Fig.7: Switch Voltage S1

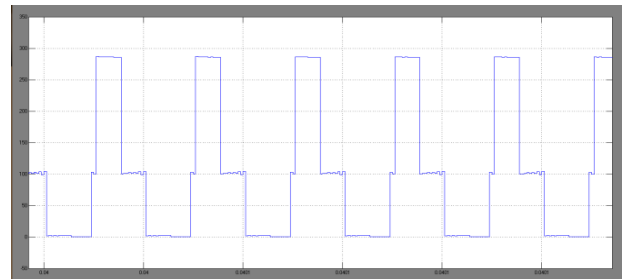

Fig.8: Switch Voltage S2

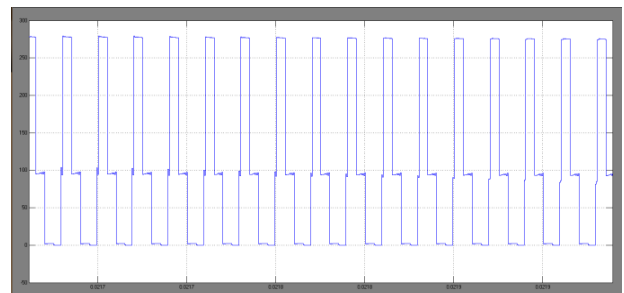

Fig.9: Switch Voltage Switch S3

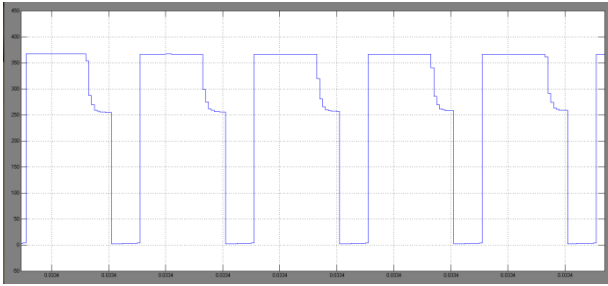

Fig.10: Switch Voltage S4

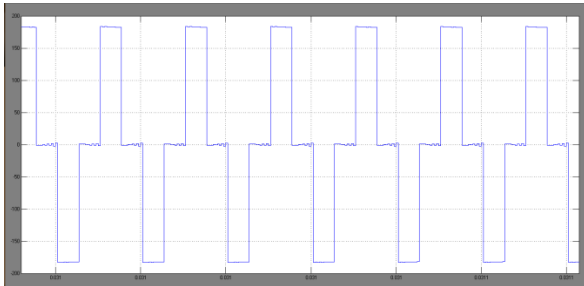

Fig.11: Three Level Output Voltage

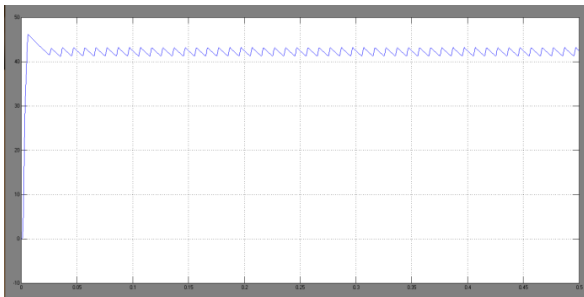

Fig.12: Output Voltage

Case ii) Single phase single stage power factor corrected converter for induction motor drive application.

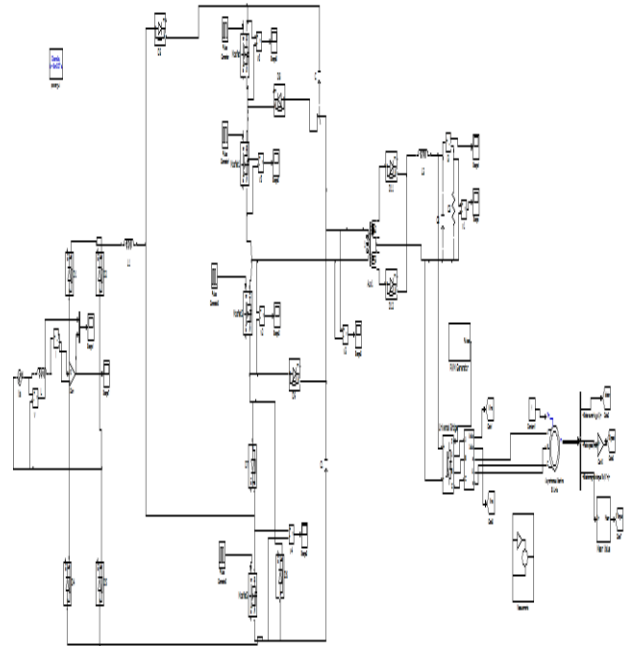

Fig.13. Simulink circuit for induction motor drive application.

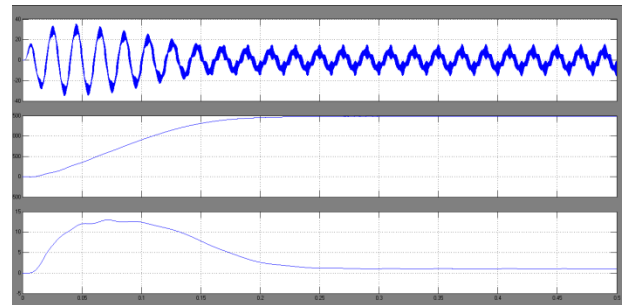

Fig.14 shows the simulation waveforms of induction motor like stator current, speed and torque

V.CONCLUSION

In this paper, a new converter topology has been proposed which has superior features over conventional topologies in terms of the required power switches and isolated dc supplies, control requirements, cost, and reliability. This will add up to the efficiency of the converter as well as reducing the size and cost of the final prototype. A new multilevel single-stage ac–dc converter is proposed in the paper. Two controllers, one controller that performs input PFC and a second controller that regulates the output voltage, with which the converter is operated. It combines the performance of two-stage converters with the reduction of cost of single-stage converters which can be considered as a outstanding feature of this converter. The paper introduces the proposed converter, explains its basic

operating principles and modes of operation, and discusses its design with respect to different dc-bus voltages.

REFERENCES

[1] Mehdi Narimani and Gerry Moschopoulos “A New Interleaved Three-Phase Single-Stage PFC AC–DC Converter”, IEEE Transactions On Industrial Electronics, Vol. 61, No. 2, February 2014.

[2] M. Schweizer and J. W. Kolar, “Design and Implementation of a Highly Efficient Three-Level T-Type Converter for Low-Voltage Applications”, IEEE Transactions on Power Electronics, Vol. 28, No. s2, pp. 899-907, February 2013.

[3] Ammar Masaoud, Hew Wooi Ping and Ayoub Suliman Taallah “New Three-Phase Multilevel Inverter With Reduced Number of Power Electronic Components”, IEEE Transactions On Power Electronics”, Vol. 29, No. 11, November 2014.

[4] Brindha.R, Chitra.J “A Three Level Ac-Dc Conversion with Boost Converter”, IJRASET, Volume 3 Issue V, May 2015,ISSN: 2321-9653.

[5] Mr V Jayanth Kumar and Dr O.ChandraSekhar, “A Novel Integration of Three-Level AC–DC Converter with Closed Loop Controller”, Journal of Electrical Engineering.

[6] K. Deepak Singh, Manish G Rathi, “Implementation of Three Level Integrated AC-DC Converter with Pulse Width Modulation”, IJETT, Volume 12 Number 6 - Jun 2014.

[7] N.Ashok Kumar and A.pradeep Kumar Yadav, “AN IMPROVED THREE LEVEL INTEGRATED AC-DC CONVERTER”, International Journal of Industrial Electronics and Electrical Engineering, ISSN: 2347-6982 Volume-2, Issue-11, Nov.-2014

[8] D.Swarna Rekha¹, P.Anjappa² and V.Ramesh³, “A New Single Phase Single Stage Three Level Power Factor Correction Ac/Dc Converter”, IJAREEIE, Vol. 3, Issue 6, June 2014.

[9] G.Kaviarasan , M.G Anand, “Single Phase Single Stage Power Factor Correction Converter with Phase Shift PWM Technique” International Journal of Research in Advent Technology, Vol.2, No.2, February 2014 E-ISSN: 2321-963.

[10] K. Aruna Kumari, K.Suresh, “Performance of Three Level Integrated AC-DC Converter with Hysteresis Current Control” IJAEEE, ISSN: 2278-8948, Volume-4 Issue-5,6 2015.

AUTHORS PROFILE



P. VIJAY RAVI is an M.Tech scholar at AVANTHI Institute of Engineering & Technology under JNTU, Kakinada. He received his B.E degree from Raghu Institute of Technology under Andhra University. His current research interests mainly include Power

Electronics and Industrial Drives.



T.SRINIVASA RAO is an Associate Professor and Head of the Department in AVANTHI Institute of Engineering & Technology, Visakhapatnam. He is currently working towards Ph.D. He got his M.Tech

degree from GITAM University. His current research interests are Power Systems and Power System Analysis.



K.DURGA RAO is an Assistant Professor in AVANTHI Institute of Engineering & Technology, Visakhapatnam. He got his M.Tech degree from JNTU Kakinada and his B.E degree from SRKR

College of Engineering, Bhimavaram. His current research interests are Power Electronics and Control Systems.