



Enhancing Power Quality with Improved Dynamic Voltage Restorer for Z-Source Inverter

J. Srinu Naik

Associate professor

Department of Electrical & Electronics Engineering,
PNC&VIET, Repudi (V), Phirangipuram(M),
Guntur (Dt); A.P, India.

e-mail: speaksrinu@gmail.com

Mr. MURTHY M V N

Asst.Professor

Department of Electrical & Electronics
Engineering,

**Khallam Haranadhareddy Institute of Technology,
Guntur, A.P, India...**

Abstract-- Voltage sags and swells in the medium and low voltage distribution grid are considered to be the most frequent type of power quality problems based on recent power quality studies. Their impact on sensitive loads is severe. The impact ranges from load disruptions to substantial economic losses up to millions of dollars. Different solutions have been developed to protect sensitive loads against such disturbances but a series compensator is considered to be the most efficient and effective solution. Even the conventional concept suffers with effective controller problems. A Dynamic Voltage Restorer (DVR) is a distribution voltage DC to-AC solid-state switching converter that injects three single phase AC output voltages in series with the distribution feeder and in synchronism with the voltages of the distribution system. A DVR is interface equipment between utility and customer connected in series between the supply and load to mitigate the three major power quality problems, namely, the voltage sags, swells, and interruptions. The equations are formulated for calculating the voltages and power injected (inverter rating) from each of the three DVR phases (3-phase DVR). The modeling of Z-source based dynamic voltage restorer is carried out component wise and their performances are analyzed using MATLAB software.

Key words- Dynamic Voltage Restorer (DVR), Voltage Sags, Voltage Swells, Sensitive Load, VSI, Synchronous Reference Frame Theory

I. INTRODUCTION

Power quality may be defined as any power problems manifested in voltage, current or frequency deviations those results in failure or miss-operation of customer's equipment. Both electric utilities and end users of electrical power are becoming increasingly concerned about the quality of electric power. Power quality is an umbrella concept for multitude of individual types of power system disturbances. The issues that fall under this umbrella are not necessarily new. What is new is that engineers are now attempting to deal with these issues with a systems approach rather than as individual problems. One important and noticeable change seen is that the quality of electricity supplied is now subject to

legislation which considers it to be no different from other goods and services.

In addition to this, problem of shoot through or cross conduction may destroy whole device and EMI causes mis-gating which again leads to shoot through problem and kills reliability. We can prefer CSI also but again the demerits of traditional CSI includes same problem as given in VSI. Hence to defeat the above problems of the traditional VSI and current source inverter (CSI), an impedance source inverter (Source inverter) is presented that can be use for implementing dc-to ac, ac-to-dc, ac-to-ac, and dc-to-dc power conversions and applications. Z-Source inverter is a single-stage converter. It also performs both buck-boost energy conversions utilizing the LC impedance network. It employs a unique impedance network to couple either the converter main circuit to power source and load or another converter. This feature cannot be observed in the traditional voltage and current-source converters where a capacitor and inductor are utilized, respectively [3].

Voltage swells are not much significant as voltage sags because they are less frequent in distribution systems. Voltage swell and sag can effects sensitive appliances (such as found in chemical plants or semiconductor) to shutdown or fail as well as create a abundant current unbalance that could trip breakers or blow fuses . These results can be very costly for the customer, ranging from minor quality alterations to production downtime and apparatus damage [5-7]. There are many conflicting methods to mitigate voltage swells and sags, but the use of a convention Power appliance is examined to be the most productive method. Energizing a large capacitor bank or Switching off a large inductive load is a characteristic system event that results swells [1]. This paper introduces Dynamic Voltage Restorer and its

operating principle. Then, a simple control based on Hysteresis voltage control method is used to compensate voltage swells/sags. At the end, MATLAB/SIMULINK

model based simulated results were extant to certify the productiveness of the suggested control method of DVR. Voltage sag is the most serious power quality conundrums faced by industrial customers. Voltage sag is familiar causes for malfunctioning in production plants. Voltage sag is short term shrinkage in voltage magnitude. According to IEEE standard 1159 voltage sag is “a decrease in RMS voltage between 10 to 90 % at a power frequency for durations from 0.5 cycles to 1 minute”.

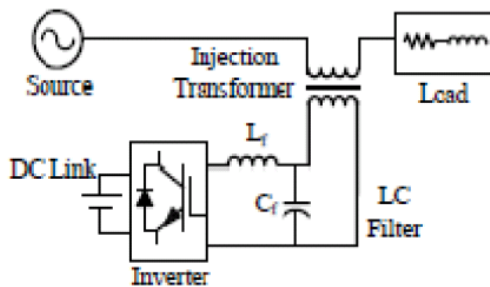

Fig. 1. Basic Components of a DVR

During voltage sag, the DVR injects a voltage to restore the load supply voltages. The DVR needs a source for this energy. Two types of system are considered; one using stored energy to supply the delivered power as shown in Figure 1, and the other having no internal energy storage. There are a number of voltage swell/sag mitigating schemes available but the use of custom power service is deliberated to the most productive scheme. This paper introduce basic concept of DVR (Dynamic Voltage Restore). DVR inject an compatible voltage magnitude with an compatible phase angle dynamically [4]. Dynamic compensating signals are determine based on the difference between desired and actual values [5]. Main components of DVR are voltage source converter, injecting transformer, passive filter, and energy storage device. The performance of DVR depends on the efficiency control technique of switching of voltage source inverter (VSI). In this paper Hysteresis Voltage control based simple control method is used to compensate voltage sag/swell.

II.SYSTEM DISCRIPTION

DVR is a power electronic based device that injects voltage into the system to control the load side voltage. It is normally situated between supply and critical load feeder. The basic function of DVR is to boost up the load

side voltage in the occurrence of interference in order to elude any power disturbance to the load. There are many control technique available to implement the DVR. The

primary function of DVR is to compensate voltage sags and swells but it can also perform the tasks such as: harmonic compensation, reduction of transient in voltage and fault current limitation. The main parts of DVR are injection transformer, harmonic filter, a voltage source converter, energy storage device and control & protection system.

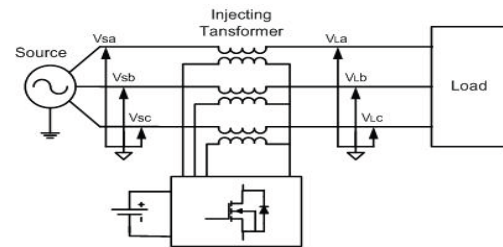

Fig. 2. Basic Principle of DVR

Fig. 2. shows the basic compensation principle of dynamic voltage restore. A voltage source inverter (VSI) is used as the series active power filter. This is controlled so as to draw or inject a compensating voltage V_{inj} from or to the supply, such that it cancels voltage harmonics on the load side i.e. this dynamic voltage restore (DVR) generates the distortions opposite to the supply harmonics.

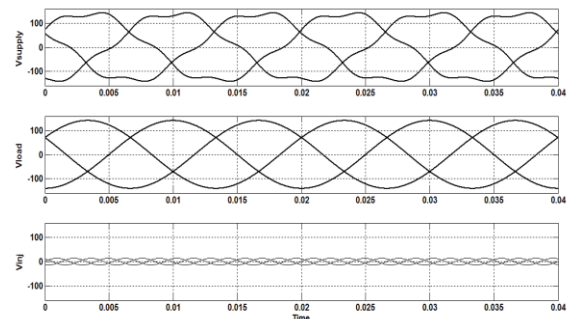

Fig. 3. Waveforms for the supply voltage, desired load voltage and the compensating voltage

Fig. 3. shows the different waveforms i.e. source voltage, desired load voltage and the compensating voltage injected by the DVR which contains all the harmonics, to make the load voltage purely sinusoidal. This is the basic principle of series active power filter to eliminate the supply voltage harmonics.



POWER QUALITY ISSUES	
NON-LINEAR LOADS	POWER QUALITY PROBLEMS
Power converters/power drives	Current harmonics/poor power factor
Switched mode power supplies and UPS	Voltage interruptions
Laser printers	Voltage sag and swell
Arc lamp/Arc furnace/welding	Voltage unbalance

Table:1 CONVENTIONAL SYSTEM CONFIGURATION OF DVR

Dynamic Voltage Restorer is a series connected apparatus modeled to keep up a constant RMS voltage value across a sensitive load. The DVR cogitated contains of:

- a. a control system
- b. an energy storage
- c. a Voltage Source Converter (VSC),
- d. a harmonic filter and
- e. an injection / series transformer , as shown in Figure.4

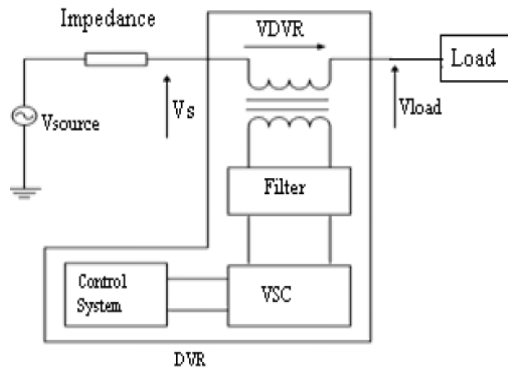

Fig.4 Schematic diagram of DVR

The main aim of a DVR is the conservation of sensitive loads from voltage swells/sags coming from the network.

Therefore as shown in Fig.4, the DVR is situated on access of sensitive loads. If a fault happens on other lines,

DVR injects series voltage VDVR and make amends load voltage to pre fault value. The instantaneous amplitudes of the three inserted phase voltages are controlled such as to abolish any harmful consequences of a bus fault to the load voltage V_L . This means that any differential voltages caused by transient disruptions in the ac feeder will be make amends by an corresponding voltage produced by the converter and injected on the medium voltage level through the booster transformer.

The DVR works individualistically of the class of fault or any contingency that occurs in the system, provided that the whole system endures connected to the supply grid, i.e. the line breaker does not trip. For most practical cases, a more economical design can be achieved by only compensating the positive and negative sequence components of the voltage disturbance seen at the input of the DVR. This option is Reasonable because for a typical distribution bus configuration, the zero sequence part of a disturbance will not pass through the step down transformer because of infinite impedance for this component.

III.HYSTERESIS VOLTAGE CONTROL TECHNIQUE

The control of dynamic voltage restorer is relates with the detection of voltage sag/dip, voltage swell, and the generation of the reference voltages for injection purpose. The sag, swell detection technique is very important task for the appropriate working of dynamic voltage restorer. There are various techniques for the detection of voltage sag, swell. Some are given below. Measuring peak values of input supply, Measuring of voltage components in dq frame in a vector controller and applying phase locked loop to each phase.

Structure of DVR by using Hysteresis Voltage Control Technique:

Following figure explains the main control diagram of dynamic voltage restorer with hysteresis voltage controller. It mainly consists of three phase IGBT inverter, Energy storage, booster transformer and the hysteresis voltage controller. The hysteresis controller mainly requires two voltage signals, one is from supply side voltage signal and another is from booster transformer which is voltage injected by dynamic voltage restorer. The controller compares these two signals and according to these signals switching pattern is established.

The hysteresis switching method is well explained in fig.5

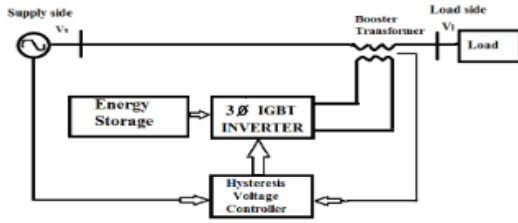

Fig.5 Hysteresis switching pattern

Z-source inverter has X-shaped impedance network on its DC side, which interfaces the source and inverter H-bridge. It facilitates both voltage-buck and boost capabilities. The impedance network composed of split inductors and two capacitors. The supply can be DC voltage source or DC current source or AC source. Z-source inverter can be of current source type or voltage source type. Fig. 3 shows the general block diagram of Z-Source inverter voltage.

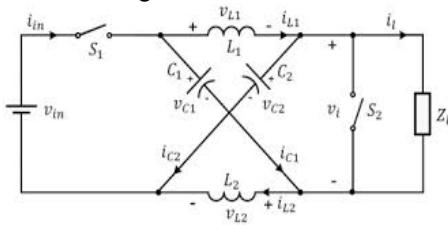

Fig. 6 General Block Diagram of Z-Source Inverter

Z-Source inverter operation is controlled by multiple pulse width modulation. The output of the Z-Source inverter is controlled by using pulse width modulation, generated by comparing a triangular wave signal with an adjustable DC reference and hence the duty cycle of the switching pulse could be varied to synthesize the required conversion.

IV.SIMULATION RESULTS

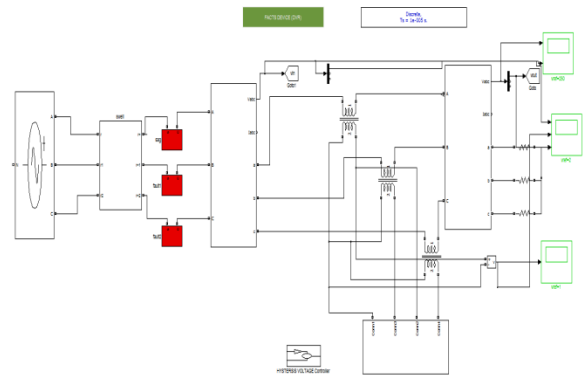

Fig.7 MATLAB/Simulink model of three phase inverter.

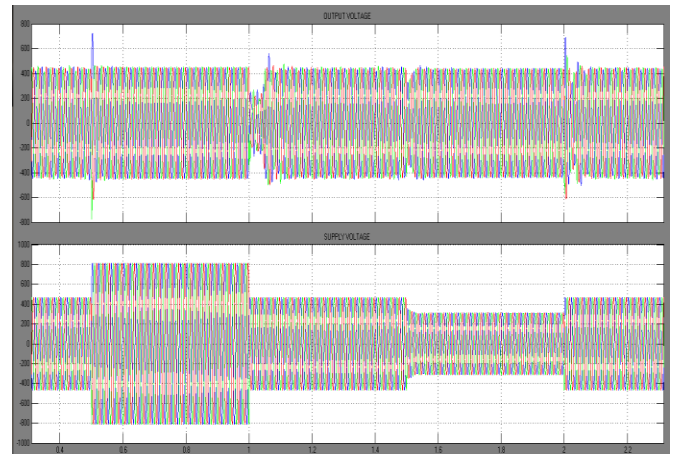

Fig.8 Simulated output wave forms of the source voltage and output voltage

Even there is fault and sag appeared from the source side due the presence of the DVR load voltage is maintained constant

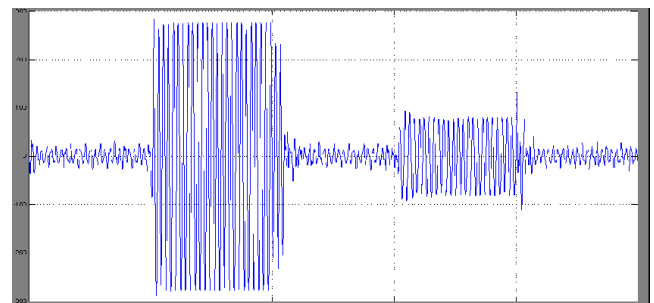

Fig.9 Simulated output wave form from the Compensating voltages generated by the DVR.

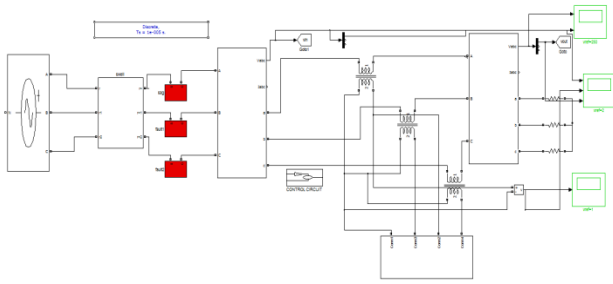

Fig.10 Matlab/Simulink model of fault and Swell generation and mitigated by Z-source DVR

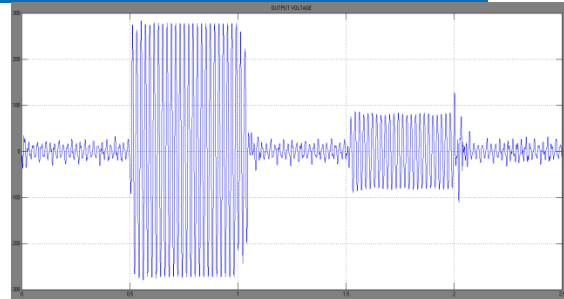

Fig.13 Simulated output wave form from the Compensating voltages generated by the DVR.

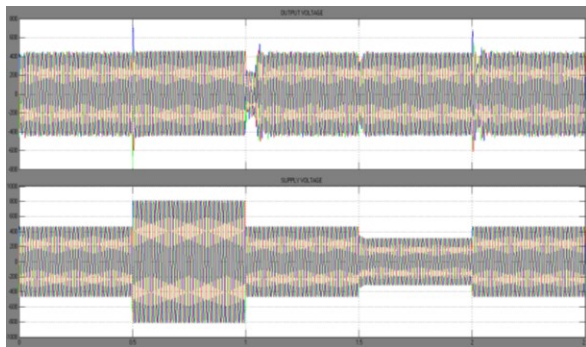

Fig.11 Simulated output wave forms of the source voltage and load voltage

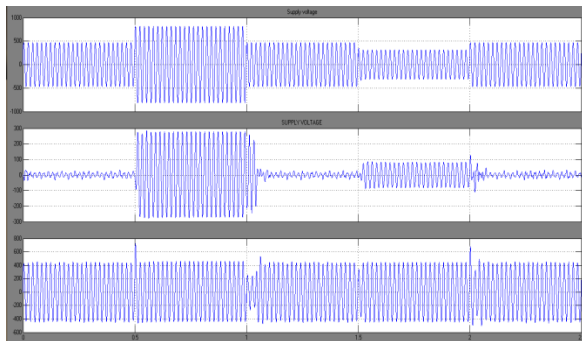

Fig.12 Simulated output wave form of Load voltage

Even there is fault and sag appeared from the source side due the presence of the DVR load voltage is maintained constant

V.CONCLUSION

Simulation of Z-source DVR for Power Quality Improvement is one of the techniques to improve the power quality by using Z-source DVR. In this paper the hysteresis voltage control technique is used for controlling the dynamic voltage restorer and generation of switching pulses for the inverter of DVR. The Hysteretic Voltage Control can provide fast transient response without additional loop compensation, with the benefits of low cost and ease of implementation. It is observed that throughout fault condition the power factor at input side is maintained unity. The total system output voltage is maintained constant throughout the fault condition. The simulation results show that the developed control technique with proposed single phase DVR is simple and efficient. These all results shown in above section and verified by using MATLAB/SIMULINK software

REFERENCES

- [1] N.G. Hingorani, "Introducing Custom Power in IEEE Spectrum," 32p, pp. 41-48, 1995.
- [2] IEEE Std. 1159 – 1995, "Recommended Practice for Monitoring Electric Power Quality".
- [3] P. Boonchiam and N. Mithulananthan, "Understanding of Dynamic Voltage Restorers through MATLAB Simulation," *Thammasat Int. J. Sc. Tech.*, Vol. 11, No. 3, July-Sept 2006.
- [4] J. G. Nielsen, M. Newman, H. Nielsen, and F. Blaabjerg, "Control and testing of a dynamic voltage restorer (DVR) at medium voltage level," *IEEE Trans. Power Electron.* vol. 19, no. 3, p.806, May 2004.
- [5] A. Ghosh and G. Ledwich, "Power Quality Enhancement Using Custom Power Devices," Kluwer Academic Publishers, 2002.
- [6] S. Chen, G. Joos, L. Lopes, and W. Guo, "A nonlinear control method of dynamic voltage restorers," in 2002 IEEE 33rd Annual Power Electronics Specialists Conference, 2002, pp. 88-93.
- [7] R. Buxton, "Protection from voltage dips with the dynamic voltage restorer," in IEE Half Day Colloquium on Dynamic Voltage Restorers Replacing Those Missing Cycles, 1998, pp. 3/1- 3/6.



-
- [8] H. Awad, J. Svensson, M. Bollen, "Mitigation of Unbalanced Voltage Dips Using Static Series Compensator", IEEE Trans. On Power Elec., Vol. 19, No. 13, May 2004
- [9] B. Singh, A. Adya, J. Gupta, "Power Quality Enhancement with DST/AT/COM for small Isolated Alternator feeding Distribution System" Power Electronics, And Drive System 2005, (PEDS 2005), Vol. 1, 16-18 Jan Pages: 274-279
- [10] Nielsen, Newman, H. Nielsen, and F. Blaabjerg, "Control and testing of a dynamic voltage restorer (DVR) at medium voltage level," IEEE Trans. Power Electronics. vol. 19, no. 3, pp. 806-813, May 2004.
- [11] J. G. Nielsen, "Design and Control of a Dynamic Voltage Restorer," Ph.D. dissertation, Institute of Energy Technology, Aalborg Univ., Aalborg, Denmark, 2002.
- [12] Boonchiam P, and Mithulananthan N, "Understanding of Dynamic Voltage Restorers through MATLAB Simulation". Thammasat Int. J. Sc. Tech., Vol. 11, No. 3, July-Sept 2006.
- [13] Yusuf K: "Industrial power quality problems Electricity Distribution. IEEE Conf. Publ No. 482, Vol: 2, 18-21 June 2001 Pages: 5 pp. vol. 2.
- [14] Fawzi AL Jowder, "Modeling and Simulation of Dynamic Voltage Restorer (DVR) Based on Hysteresis Voltage Control" The 33rd Annual Conference of the IEEE Industrial Electronics Society (IECON) Nov. 5-8, 2007, Taipei, Taiwan
- [15] BenachaibaChellali, FERDI Brahim, "Voltage Quality Improvement Using DVR," Electrical Power Quality and Utilizations, Journal Vol. XIV, No. 1, 2008
- [16] M. Bollen. "Understanding Power Quality Problems, voltage sags and Interruptions." IEEE press, 1999