

# Design and Thermal Analysis of Combustion Outer Case for Turbo Engine



Dhondi Sindhuja  
M.Tech (Thermal engineering),  
P.G. Scholar

Nishitha College of engineering and technology  
[chinnu.sinduja@gmail.com](mailto:chinnu.sinduja@gmail.com)



Rangdal Srikanth  
Mtech(AMS), Asst professor

Nishitha College of engineering and technology

## ABSTRACT

A turbocharger or turbo is a gas compressor that uses the turbine driven forced induction device that increases an engine's efficiency and power by forcing extra air into the combustion chamber. A turbocharger has the compressor powered by a turbine. The turbine is driven by the exhaust gas from the engine. It does not use a direct mechanical drive. This helps improve the performance of the turbocharger. The main problems with the turbo charger are oil leakage, damage of blades, whistling, sluggish, and outer case compression problem to overcome this problem many of the peoples work on the problem and they came out with new solutions to it. The objective of this project is to be design the outer case of a turbocharger for a diesel engine to increase its power and efficiency, and showing the advantage of designing of a turbocharger. The project tends to usage of new materials is required. In the present work impeller was designed

with three different materials. The investigation can be done by using Creo-2 and ANSYS software. The Creo-2 is used for modeling the impeller and analysis is done in ANSYS .ANSYS is dedicated finite element package used for determining the variation of stresses, strains and deformation across profile of the impeller.

## INTRODUCTION

### Internal Combustion Engine

The internal combustion engine is the powerhouse of a variety of machines and equipment ranging from small lawn equipment to large aircraft or boats. Given the focus of this paper, the most important machine powered by an internal combustion engine is the automobile. The engine literally provides the driving force of the car while also directly or indirectly powering just about every other mechanical and electrical system in the modern automobile. While there are several types of internal

combustion engines that cover the aforementioned large range of applications, they all basically do the same thing.

They all convert the chemical energy stored in a fuel of some kind into mechanical energy, which can then be converted into electrical energy. The three most common types of internal combustion are the 4-stroke gasoline engine, the 2-stroke gasoline engine, and the diesel engine. A brief description of each the common types of internal combustion engine are provided below.

The 4-stroke gasoline engine is the most frequently used engine in cars and light trucks as well as in large boats and small aircraft. The major components of the cylinder of a 4-stroke gasoline engine. While the arrangement and number of the cylinders in an engine tends to vary, the parts that

make up an individual cylinder remain pretty constant. The most significant component is the piston which is connected to the crankshaft via a connecting rod. The motions of the piston and crankshaft are always related, with one always forcing the other to move. The two valves, intake and exhaust, at the top of the cylinder are opened and closed by separate camshafts that precisely control the timing of each valve's movement. The spark plug at the top of the cylinder is powered by the engine battery and activated by the engine computer at the appropriate time. Finally, the entire cylinder is surrounded by coolant channels that run through the engine block to remove the massive amount of heat generated by the running engine.

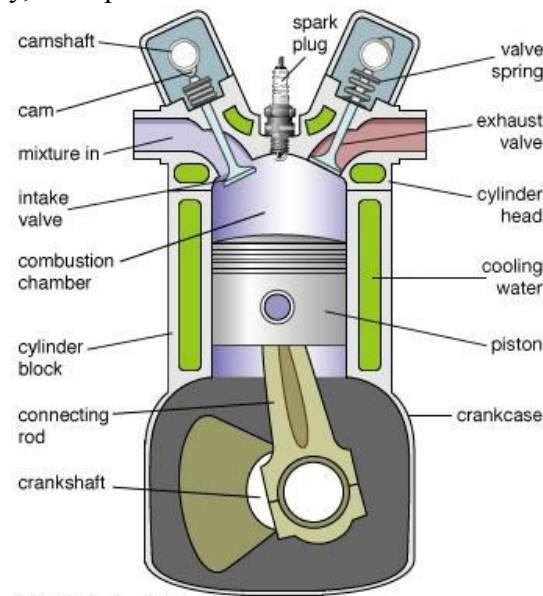

Figure 1 Components of a 4-stroke gasoline engine cylinder.

The four strokes of a 4-stroke gasoline engine, illustrated in Fig. 1.2, are intake, compression, power and exhaust. During the intake stroke, the camshaft opens the intake

valve as the crankshaft lowers the piston, which allows the cylinder to be filled with a precise mixture of air and gasoline. Once the piston reaches the bottom of the cylinder, the

camshaft closes the intake valve. The piston is now at what is known as bottom dead

center, and the cylinder is completely filled with the air/fuel mixture.

**Four-stroke cycle**

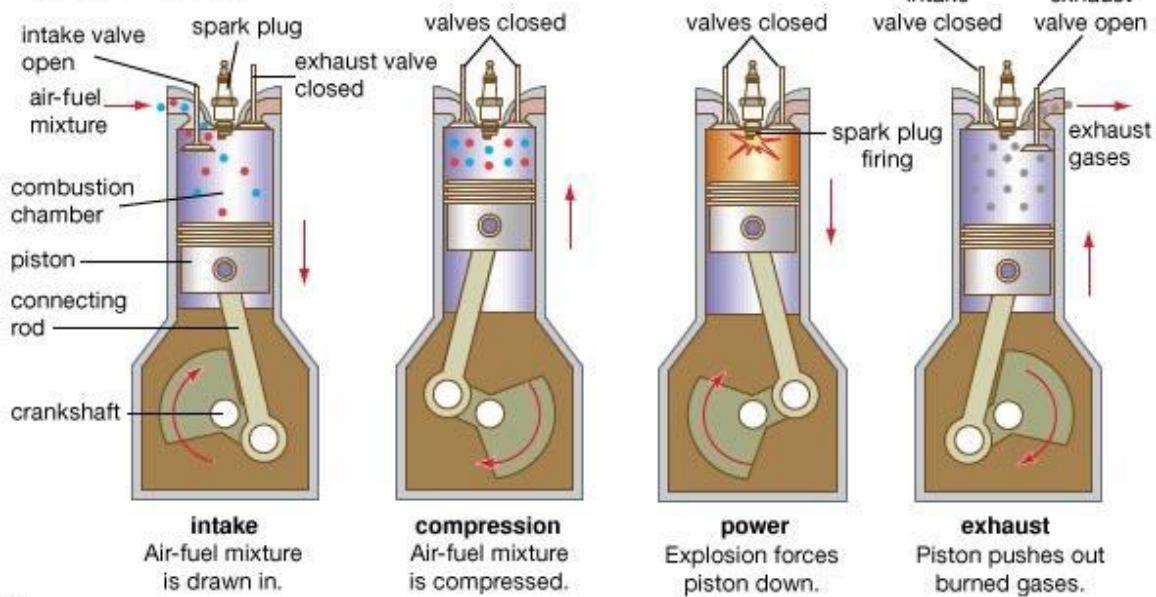

Figure 2 Engine cycle of a 4-stroke gasoline engine.

The compression stroke comes next. With both intake and exhaust valves closed, the crankshaft raises the piston, compressing the air/fuel mixture. When the piston has been raised to the top of the cylinder, it is said to be at top dead center. Once the cylinder has reached top dead center, the air/fuel mixture has been compressed as much as possible. The power stroke is next up. With the piston still at top dead center and both valves closed, the spark plug fires, igniting the compressed air/fuel mixture. Once ignited, a flame begins to move through the mixture, causing it to expand downward smoothly. This expansion downward forces the piston to move down. This means that the piston is rotating to the crankshaft, whereas the rotation of the crankshaft moves the piston in the other three strokes. The fact that the piston is driving the crankshaft means that energy is being transferred to the crankshaft. This is how an internal

combustion engine transforms chemical energy in the fuel into mechanical energy. The power stroke is completed once the expanding gases have forced the piston to bottom dead center. The final stroke is the exhaust stroke. The camshaft opens the exhaust valve as the crankshaft raises the piston, which pushes the exhaust gases out of the cylinder. Once the piston has reached top dead center, all of the exhaust gases have been removed from the cylinder. The cylinder is now ready to start the cycle over again with another intake stroke. The 2-stroke gasoline engine accomplishes the same thing as the 4-stroke gasoline engine but with half as many strokes. Since they can produce a good amount of power for their relatively small size, 2-stroke gasoline engines are found on a variety of lawn care and recreational equipment like lawnmowers, chainsaws, snowmobiles and small boat engines. They are generally not used for

larger application because they are less efficient and dirtier than their 4-stroke counterparts. Aside from having fewer strokes, 2-stroke engines differ from 4-stroke

engines in their fuel mixtures and cylinder components. The two strokes, upstroke and downstroke, of a 2-stroke engine along with the cylinder setup.

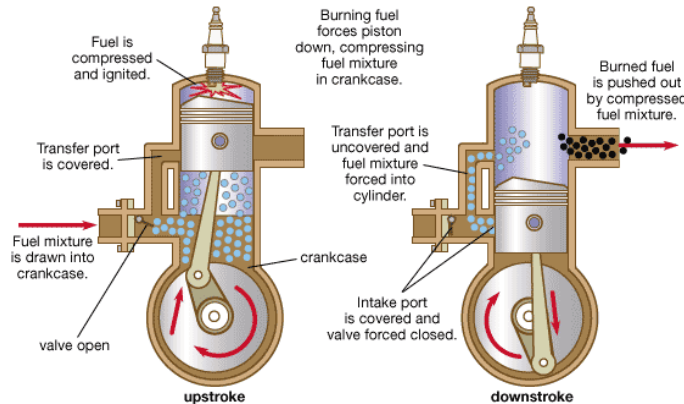

Figure 3 Engine cycle of a 2-stroke gasoline engine.

There are no camshafts or complicated valve trains involved here, meaning the piston basically has to perform more diverse functions than in 4-stroke engines. Furthermore, special two cycle oil is mixed in with the gasoline to help lubricate the piston, so the air/fuel mixture in a 2-stroke engine includes oil. When the piston is at the bottom of the cylinder, the already compressed air/fuel mixture has moved via the transfer port into the top of the cylinder. On the upstroke, the piston further compresses the air/fuel mixture, creates a vacuum in the crankcase and uncovers the intake port. The vacuum opens the intake valve and draws more air/fuel mixture into the crankcase. The spark plug fires and ignites the mixture, which forces the piston down just like in the 4-stroke cycle. On the down stroke, the piston transfers energy to the crankshaft while compressing the air/fuel mixture in the crankcase and uncovering the exhaust port. As the piston reaches the bottom of the cylinder, the compressed air/fuel mixture is again forced into the top of the cylinder via the transfer port, which forces the remaining exhaust out of the

cylinder. The cycle can now begin again. Diesel engines can have a 2-stroke cycle, but most have a 4-stroke cycle, particularly those used by large trucks. The 4-stroke diesel engine will thus be focused on. The 4-stroke diesel cycle is very similar to the 4-stroke gasoline cycle with the big differences, aside from fuel type, being the fuel injection timing and ignition method. During the intake stroke, the intake valve opens as the crankshaft lowers the piston, drawing in pure air. Once the piston reaches bottom dead center, the intake valve closes. The crankshaft then raises the piston, compressing the air. Diesel engines compress the air to much higher compression ratios than their gasoline counterparts do the air/fuel mixture, which means the compressed air reaches scorching temperatures. The compression stroke is complete when the piston reaches top dead center and the air is completely compressed. It is at this moment that the fuel is injected into the compressed air. The extreme temperature of the compressed air immediately ignites the fuel. The expanding gases then force the piston down,

transferring energy to the crankshaft. The power stroke is complete when the piston reaches bottom dead center. During the exhaust stroke, the crankshaft raises the piston, forcing the exhaust gases out of the now open exhaust valve. Once the piston reaches top dead center, the cycle is ready to begin again.

### Turbochargers

As stated in the previous section, a turbocharger is a device that uses engine exhaust gases to power a compressor that increases the pressure of the air entering the engine, which results in more power from the engine. Air enters the compressor from

the left, is compressed and then directed to the intake valve of the cylinder. Exhaust exits the exhaust valve of the cylinder, spins the turbine and is expelled. The three major pieces of a turbocharger introduced in the previous section and shown in Fig. 1.6 are the compressor, bearings section and turbine. Each of these sections has an important function and deserves further attention. It is also important to recognize in any discussion of turbo charging that turbo charging an engine involves more than just slapping a turbocharger on to the engine. An entire system must be developed for the turbocharger, including a means of temperature and pressure control.

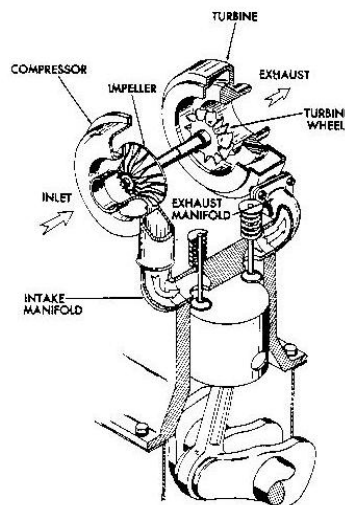

Figure 4: Simplified drawing of turbocharger and engine cylinder.

### Turbocharger as a Device

Before getting into the details of a turbocharged system, the turbocharger as a device will be described in more detail. It effectively illustrates the relationship between the three sections as well as the input and output of each section. The heart of the turbocharger is the assembly of compressor blades, shaft and turbine blades. It is this assembly that rotates at over a 100000 RPM when the turbocharger is

operational. This assembly also serves as the common connection between the three major components of the turbocharger, which otherwise are independent of each other.

The compressor blades, shaft and turbine blades that make up the rotating assembly are distinctly inside of the compressor housing, bearings housing and turbine

housing, respectively. The role of the compressor housing is to direct ambient air axially into the spinning compressor blades. The blades and housing are designed together such that the ambient air is compressed and forced into the air channel wrapped around the center of the compressor housing, which expels the compressed air tangentially. The compressed air leaves the compressor with higher pressure and temperature. The pressure increase across the compressor is known as boost. For example, if ambient air enters the compressor at atmospheric pressure (14.7psi) and leaves at a pressure of 19.7psi, the turbocharger is said to be creating 5psi of boost. Generally speaking, the higher the boost pressure, the higher the power gains but more difficulty and cost are involved in developing the system. The compressor works best at a particular combination of airflow and boost pressure. The compressor should be chosen wisely to ensure most efficient operation. The primary function of the bearings housing is to guide the rotating shaft connecting the compressor and turbine blades. This shaft is guided using either journal or ball bearings. The bearings housing has a secondary function of lubricating the shaft and bearings. This is accomplished by routing engine oil into the bearings housing, which distributes the oil around the shaft and bearings. The oil is then drained out of the bearings section at which point it can be returned to the engine. Heat from the exhaust gases can lead to oil coking, the charring of the oil on to the oil channels. This restricts oil flow and eventually destroys the bearings. Some bearings sections have water jackets that allow engine coolant to reduce the temperature of the oil.

The main function of the turbine housing is to direct exhaust gases to the turbine blades to accelerate them as quickly as possible.

Exhaust gas enters the turbine housing tangentially and travels through the channels surrounding the center of the turbine. These channels lead the air into the turbine blades, forcing them to rotate. The exhaust is then expelled from the turbine housing axially. The size of the turbine housing has a significant impact on the behavior of the turbine. In particular, changing the size of the turbine affects turbocharger response, power gains and the engine speed at which the turbocharger is most effective.

### **Turbocharger as a System**

Now that the basics of a turbocharger have been covered, the major components of a turbocharged system can be discussed. Unfortunately, a turbocharged system is a lot more complicated than the illustration. Plumbing, engine modifications, intake air temperature and boost control are all major concerns that need to be addressed. It includes all the plumbing for the intake and exhaust, oil feed and drain lines, an intercooler for temperature control and a wastegate for boost control. These components will be discussed briefly here and then at length in subsequent sections of the paper. The intake system consists of everything from the air filter to the intake ports on the engine. This includes the compressor, intercooler (see next paragraph), manifold and throttle bodies. The job of the intake system is to connect all of these components with hoses or pipes. The design of the manifold, which consists of the plenum and runners, and the throttle bodies are also considered part of the intake system. The intake system in general and specifically for this project will be discussed at length in section 6 – Intake System. The intercooler is a heat exchanger that is included to remove the unwanted heat added to the intake air by the compressor. It is impossible to prevent

the compressor from adding heat to the air as it compresses it, though the amount of heat added can be limited by choosing a properly sized compressor. It is undesirable to just allow the hot intake air to go straight to the engine as it can reduce power gains and lead to engine knocking. An intercooler is thus included in the system to remove the heat added by the compressor. The heat is removed via cross flow of a cooling fluid, either air or water. The air is then free to flow to the engine with a lower temperature but still higher than atmospheric pressure.

The concept of boost was introduced in the previous section as was the relationship between boost and the system. That is to say that while higher boost generally leads to higher power it also leads to increasingly complicated and expensive system requirements. Since a turbocharged system is rarely designed with unlimited budget and design freedom, there will always be a maximum boost that the system is designed to accommodate. This maximum boost is usually chosen based on performance goals, and the system is then designed specifically for that boost pressure. If this maximum boost pressure is exceeded, the system could very likely fail, resulting in damage to the turbocharger or engine. If left unchecked though, the turbocharger will continue to create boost well past the maximum boost pressure. A boost control system is thus added to limit the boost created by the turbocharger. A waste gate works by bleeding exhaust gas away from the turbine once the maximum boost pressure is

reached. As less exhaust reaches the turbine, the turbocharger slows down and creates less boost pressure.

The exhaust system consists of everything from the engine exhaust ports to the tailpipe. This includes the manifold, turbine, waste gate and the muffler. The job of the exhaust system is to connect and support all of these components with pipes. The design of the exhaust manifold, including the primaries and merge collectors, is considered part of the exhaust system. The final major system component is the lubrication system for the turbocharger bearings. In the drawing, this system consists of an oil feed line and an oil drain line between the turbocharger bearings and the engine. The oil feed line is connected to the engine at a location with positive oil pressure, and the oil drain line is connected to the engine's oil pan. More complicated systems including dedicated pumps and oil reserves are not uncommon. The coolant lines between the turbocharger bearings and the engine's radiator circuit are not included in the figure as water jackets are not available on all turbochargers and thus are not considered to be standard. In addition to these components, any high boost turbocharged system is going to require modifications to various engine parts. Electrical and ignition systems may need to be upgraded to ensure proper ignition. The fuel injection systems may need to be upgraded to maintain the correct AFR. The throttle bodies and valve train may need to be changed to provide for proper flow conditions

### **Input Data of Turbo Casing:**

Engine capacity (L) Up to 7

Output range (hp) 100 to 310

Airflow (max) 0.46 kg/s

Length (mm) 250

Width (mm) 240

Height (mm) 220

Mass (kg) 16 to 17

**Turbo outer Casing stress analysis**

Stain less steel	CF8C plus cast stain less steel	HK30Nb stainless alloy
Density	7.96	7.81
Ductility	0.32	0.34
Elastic limit	209MPA	207MPA
Thermal conductivity	14.54w/mk	15.23w/mk
Heat input	350°c	350°c

**3-D MODELING OF TURBO CASING**

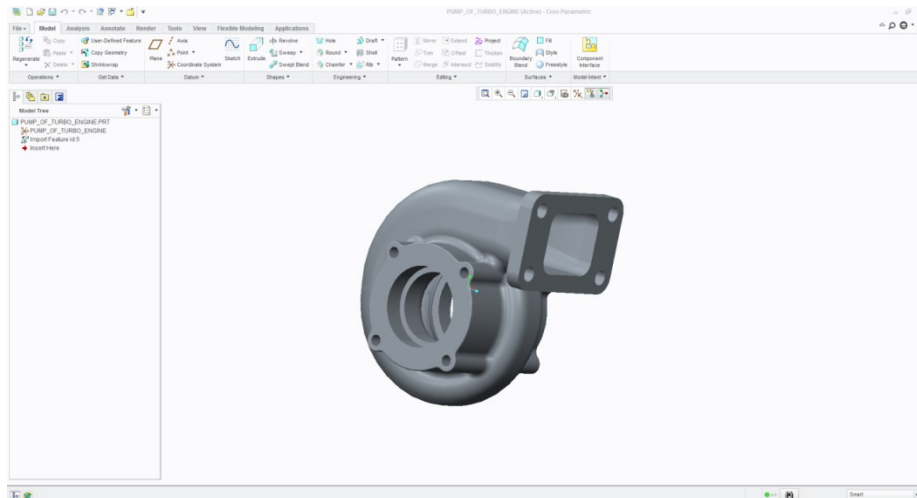



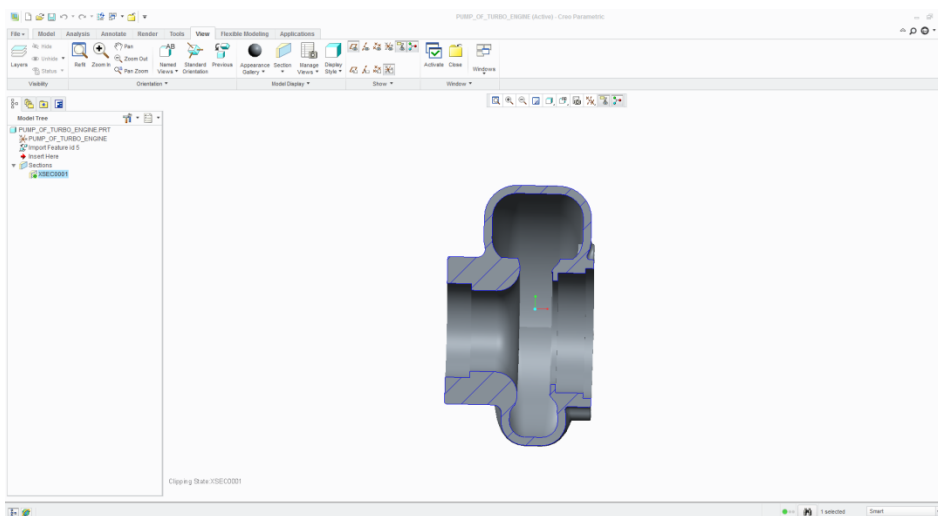
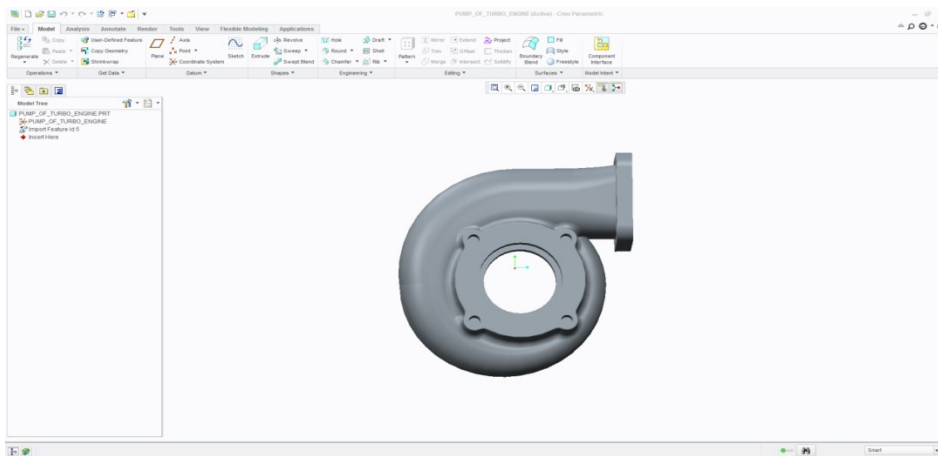
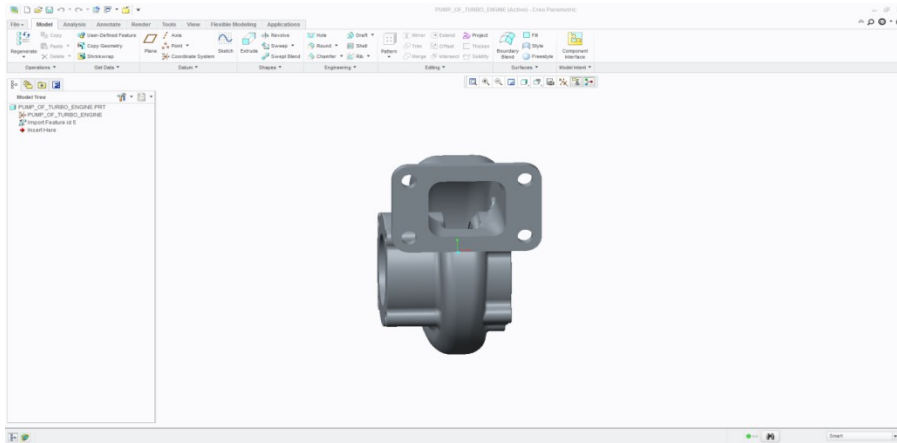

## MODAL ANALYSIS

A modal analysis is typically used to determine the vibration characteristics (natural frequencies and mode shapes) of a structure or a machine component while it is being designed. It can also serve as a starting point for another, more detailed, dynamic analysis, such as a harmonic response or full transient dynamic analysis. Modal analyses, while being one of the most basic dynamic analysis types available in ANSYS, can also be more computationally time consuming than a typical static analysis. A reduced solver, utilizing automatically or manually selected master degrees of freedom is used to

drastically reduce the problem size and solution time.

### HARMONIC ANALYSIS

Used extensively by companies who produce rotating machinery, ANSYS Harmonic analysis is used to predict the sustained dynamic behavior of structures to consistent cyclic loading. A harmonic analysis can be used to verify whether or not a machine design will successfully overcome resonance, fatigue, and other harmful effects of forced vibrations

### THERMAL ANALYSIS OF TUBO CASING

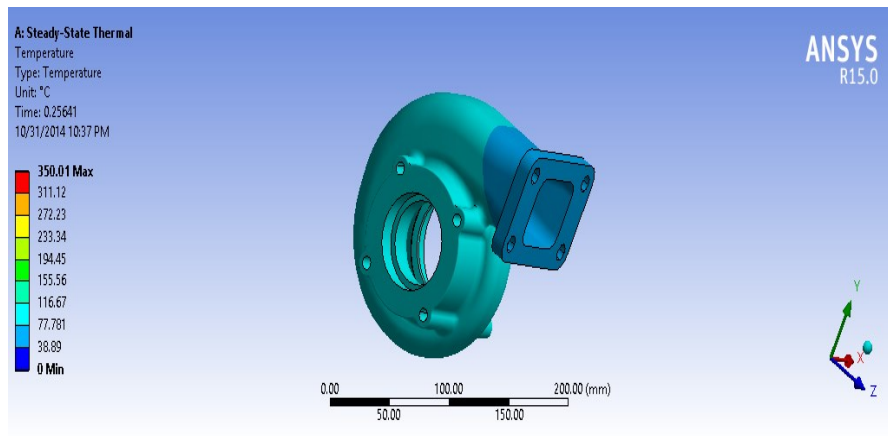

#### Material Properties:

Stain less steel	HK30Nb stainless alloy
Density	7.81
Ductility	0.34

Elastic limit	207MPA
Thermal conductivity	15.23w/mk
Heat input	350°c

Units:

**TABLE 1**

Unit System	Metric (mm, kg, N, s, mV, mA) Degrees rad/s Celsius
Angle	Degrees
Rotational Velocity	rad/s
Temperature	Celsius

**TABLE 2**  
**Model (A4) > Geometry**

Object Name	<i>Geometry</i>
State	Fully Defined
<b>Definition</b>	
Source	E:\sanya\turbocasingthermalanalysisinputdata\sanyatechnologie\turbo housing\turbo housing\pump_of_turbo_engine3.stp
Type	Step
Length Unit	Meters
Element Control	Program Controlled
Display Style	Body Color
<b>Bounding Box</b>	
Length X	109. mm
Length Y	170.87 mm
Length Z	160.7 mm
<b>Properties</b>	
Volume	5.1095e+005 mm <sup>3</sup>
Mass	0. kg
Scale Factor Value	1.
<b>Statistics</b>	
Bodies	1
Active Bodies	1
Nodes	25639
Elements	14257

Mesh Metric	None
<b>Basic Geometry Options</b>	
Solid Bodies	Yes
Surface Bodies	Yes
Line Bodies	No
Parameters	Yes
Parameter Key	DS
Attributes	No
Named Selections	No
Material Properties	No
<b>Advanced Geometry Options</b>	
Use Associativity	Yes
Coordinate Systems	No
Reader Mode Saves Updated File	No
Use Instances	Yes
Smart CAD Update	No
Compare Parts On Update	No
Attach File Via Temp File	Yes
Temporary Directory	C:\Users\kishore\AppData\Local\Temp
Analysis Type	3-D
Mixed Import Resolution	None
Decompose Disjoint Geometry	Yes
Enclosure and Symmetry Processing	Yes

**TABLE 3: Model (A4) > Geometry > Parts**

Object Name	PUMP_OF_TURBO_ENGINE
State	Meshed
Graphics Properties	

Visible	Yes
Transparency	1
<b>Definition</b>	
Suppressed	No
Stiffness Behavior	Flexible
Coordinate System	Default Coordinate System
Reference Temperature	By Environment
<b>Material</b>	
Assignment	material 2
Nonlinear Effects	Yes
Thermal Strain Effects	Yes
<b>Bounding Box</b>	
Length X	109. mm
Length Y	170.87 mm
Length Z	160.7 mm
<b>Properties</b>	
Volume	5.1095e+005 mm <sup>3</sup>
Mass	0. kg
Centroid X	-10.023 mm
Centroid Y	15.766 mm
Centroid Z	3.0438 mm
Moment of Inertia Ip1	0. kg·mm <sup>2</sup>
Moment of Inertia Ip2	0. kg·mm <sup>2</sup>
Moment of Inertia Ip3	0. kg·mm <sup>2</sup>
<b>Statistics</b>	
Nodes	25639
Elements	14257
Mesh Metric	None

**Coordinate System:**

**TABLE 4: Model (A4) > Coordinate Systems > Coordinate System**

Object Name	Global Coordinate System
State	Fully Defined
<b>Definition</b>	

Type	Cartesian
Coordinate System ID	0.
<b>Origin</b>	
Origin X	0. mm
Origin Y	0. mm
Origin Z	0. mm
<b>Directional Vectors</b>	
X Axis Data	[ 1. 0. 0. ]
Y Axis Data	[ 0. 1. 0. ]
Z Axis Data	[ 0. 0. 1. ]

**TABLE 5: Model (A4) > Mesh**

Object Name	<i>Mesh</i>
State	Solved
<b>Defaults</b>	
Physics Preference	Mechanical
Relevance	0
<b>Sizing</b>	
Use Advanced Size Function	Off
Relevance Center	Coarse
Element Size	Default
Initial Size Seed	Active Assembly
Smoothing	Medium
Transition	Fast
Span Angle Center	Coarse
Minimum Edge Length	2.9763e-002 mm
<b>Inflation</b>	
Use Automatic Inflation	None
Inflation Option	Smooth Transition
Transition Ratio	0.272
Maximum Layers	5
Growth Rate	1.2
Inflation Algorithm	Pre
View Advanced Options	No
<b>Patch Conforming Options</b>	
Triangle Surface Meshed	Program Controlled
<b>Patch Independent Options</b>	

Topology Checking	Yes
<b>Advanced</b>	
Number of CPUs for Parallel Part Meshing	Program Controlled
Shape Checking	Standard Mechanical
Element Midsize Nodes	Program Controlled
Straight Sided Elements	No
Number of Retries	0
Extra Retries For Assembly	Yes
Rigid Body Behavior	Dimensionally Reduced
Mesh Morphing	Disabled
<b>Defeaturing</b>	
Pinch Tolerance	Please Define
Generate Pinch on Refresh	No
Automatic Mesh Based Defeaturing	On
Defeaturing Tolerance	Default
<b>Statistics</b>	
Nodes	25639
Elements	14257
Mesh Metric	None

### Steady State Thermal (A5)

TABLE 6: Model (A4) > Analysis

Object Name	Steady-State Thermal (A5)
State	Solved
<b>Definition</b>	
Physics Type	Thermal
Analysis Type	Steady-State
Solver Target	Mechanical APDL
<b>Options</b>	
Generate Input Only	No

**TABLE 7: Model (A4) > Steady-State Thermal (A5) > Initial Condition**

Object Name	Initial Temperature
State	Fully Defined
<b>Definition</b>	
Initial Temperature	Uniform Temperature
Initial Temperature Value	22. °C

**TABLE 8: Model (A4) > Steady-State Thermal (A5) > Analysis Settings**

Object Name	<b>Analysis Settings</b>
State	Fully Defined
<b>Step Controls</b>	
Number Of Steps	1.
Current Step Number	1.
Step End Time	1. s
Auto Time Stepping	Program Controlled
<b>Solver Controls</b>	
Solver Type	Program Controlled
<b>Radiosity Controls</b>	
Radiosity Solver	Program Controlled
Flux Convergence	1.e-004
Maximum Iteration	1000.
Solver Tolerance	1.e-007 W/mm <sup>2</sup>
Over Relaxation	0.1
Hemicube Resolution	10.
<b>Nonlinear Controls</b>	
Heat Convergence	Program Controlled
Temperature	Program Controlled



Convergence	
Line Search	Program Controlled
<b>Output Controls</b>	
Calculate Thermal Flux	Yes
General Miscellaneous	No
Store Results At	All Time Points
<b>Analysis Data Management</b>	
Solver Files Directory	C:\Users\kishore\AppData\Local\Temp\WB_CHANDU_kishore_35752_2\unsaved_project_files\dp0\SYS\MECH\
Future Analysis	None
Scratch Solver Files Directory	
Save MAPDL db	No
Delete Unneeded Files	Yes
Nonlinear Solution	Yes
Solver Units	Active System
Solver Unit System	mmm

TABLE 9: Model (A4) > Steady-State Thermal (A5) > Loads

Object Name	<i>Temperature</i>	<i>Convection</i>
State	Fully Defined	
<b>Scope</b>		
Scoping Method	Geometry Selection	
Geometry	41 Faces	1 Body
<b>Definition</b>		
Type	Temperature	Convection
Magnitude	350. °C (ramped)	
Suppressed	No	
Film Coefficient		Tabular Data
Coefficient Type		Average Film Temperature
Ambient Temperature		22. °C (ramped)
Convection Matrix		Program Controlled
Edit Data For		Film Coefficient
<b>Tabular Data</b>		

Independent Variable	Temperature
<b>Graph Controls</b>	
X-Axis	Temperature

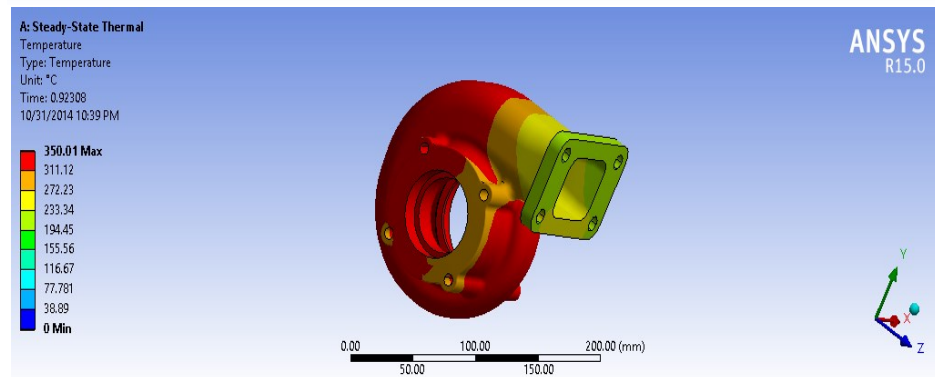
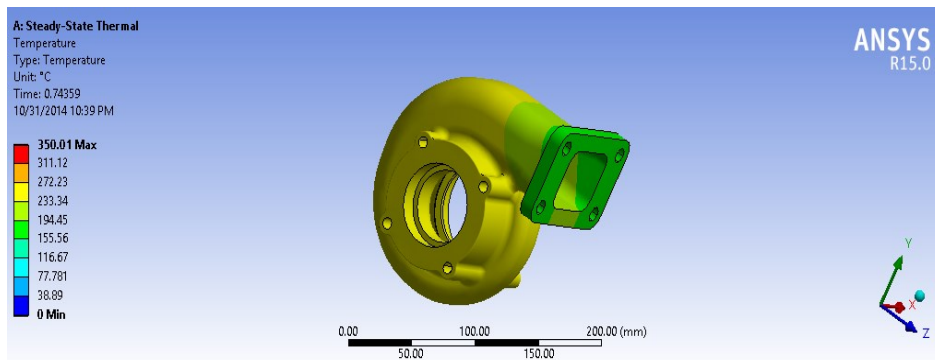
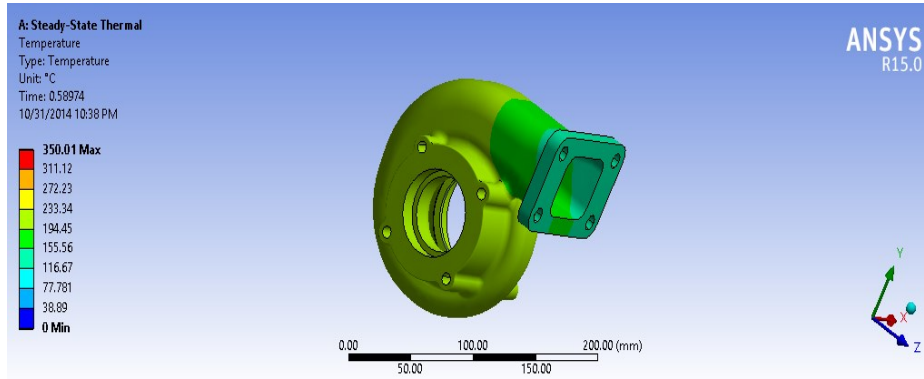

**TABLE 10: Model (A4) > Steady-State Thermal (A5) > Convection**

Temperature [°C]	Convection Coefficient [W/mm <sup>2</sup> ·°C]
1.	9.5e-007

10.	2.05e-006
100.	4.41e-006
200.	5.56e-006
300.	6.36e-006
500.	7.54e-006
700.	8.43e-006
1000.	9.5e-006

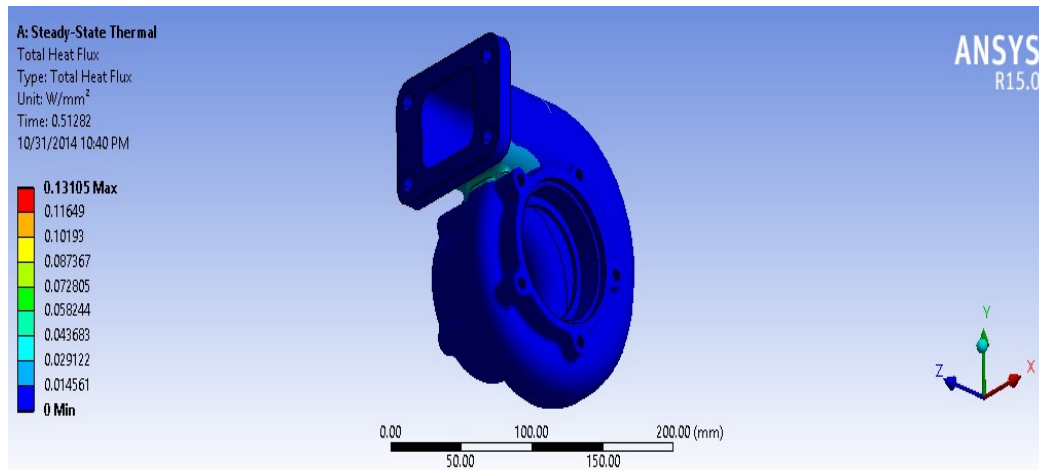

TABLE 11: Model (A4) > Steady-State Thermal (A5) > Solution

Object Name	<i>Solution (A6)</i>
State	Solved
<b>Adaptive Mesh Refinement</b>	
Max Refinement Loops	1.
Refinement Depth	2.
<b>Information</b>	
Status	Done

TABLE 12: Model (A4) > Steady-State Thermal (A5) > Solution (A6) > Solution Information

Object Name	<i>Solution Information</i>
State	Solved
<b>Solution Information</b>	
Solution Output	Solver Output

Update Interval	2.5 s
Display Points	All
<b>FE Connection Visibility</b>	
Activate Visibility	Yes
Display	All FE Connectors
Draw Connections Attached To	All Nodes
Line Color	Connection Type
Visible on Results	No
Line Thickness	Single
Display Type	Lines

TABLE 13: Model (A4) > Steady-State Thermal (A5) > Solution (A6) > Results

Object Name	<i>Temperature</i>	<i>Total Heat Flux</i>
State	Solved	
<b>Scope</b>		
Scoping Method	Geometry Selection	
Geometry	All Bodies	
<b>Definition</b>		
Type	Temperature	Total Heat Flux
By	Time	
Display Time	Last	
Calculate Time History	Yes	
Identifier		
Suppressed	No	
<b>Results</b>		
Minimum	235.63 °C	2.2085e-005 W/mm <sup>2</sup>
Maximum	350.01 °C	0.13105 W/mm <sup>2</sup>
<b>Minimum Value Over Time</b>		
Minimum	235.63 °C	2.2085e-005 W/mm <sup>2</sup>
Maximum	235.63 °C	2.2085e-005 W/mm <sup>2</sup>
<b>Maximum Value Over Time</b>		
Minimum	350.01 °C	0.13105 W/mm <sup>2</sup>
Maximum	350.01 °C	0.13105 W/mm <sup>2</sup>
<b>Information</b>		
Time	1. s	
Load Step	1	

Substep	1	
Iteration Number	3	
<b>Integration Point Results</b>		
Display Option		Averaged
Average Across Bodies		No

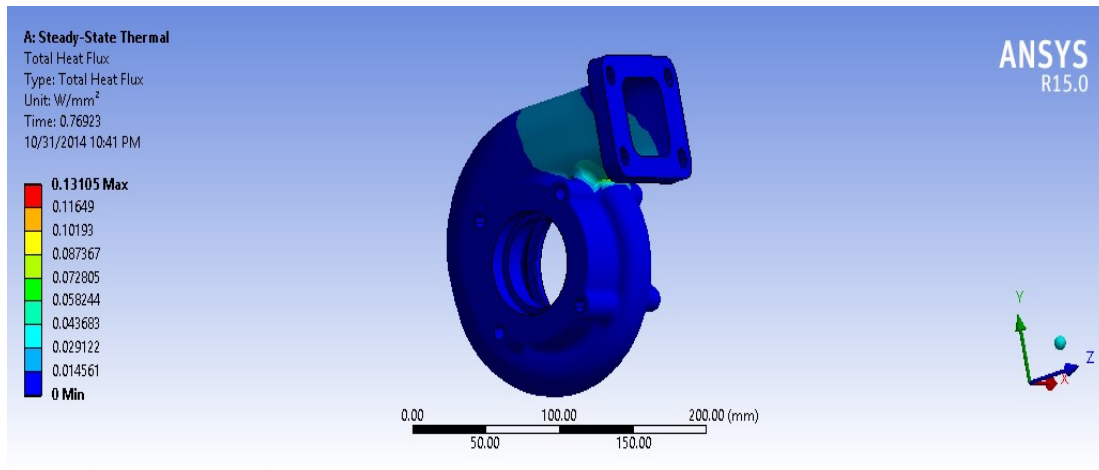
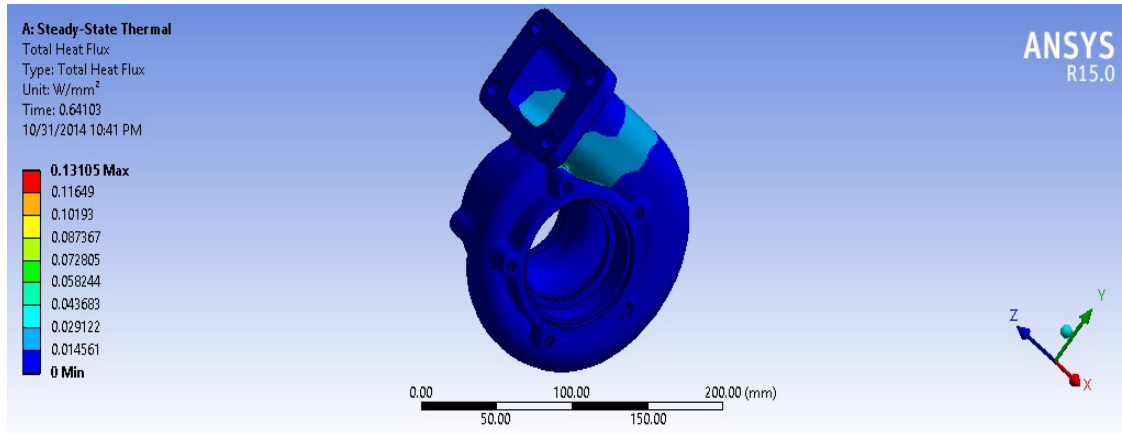

## Material Data

TABLE 14: Material 1 > Constants

Thermal Conductivity	1.523e-002 W mm <sup>-1</sup> C <sup>-1</sup>
----------------------	-----------------------------------------------

## THERMAL ANALYSIS OF TUBO CASING Material -2

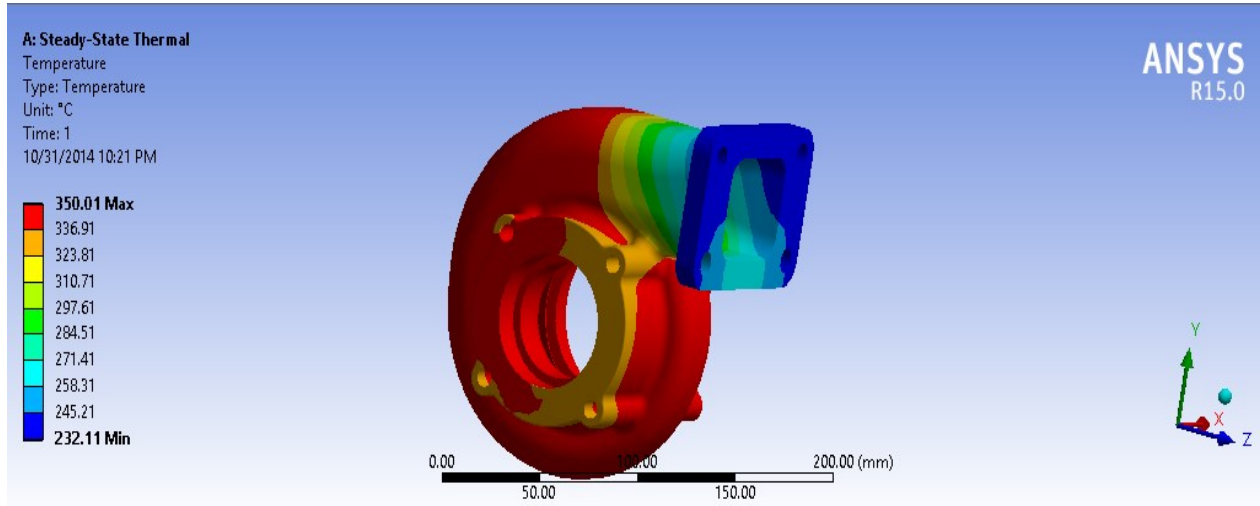

**Material Properties**

Stain less steel	CF8C plus cast stain less steel
Density	7.96
Ductility	0.32
Elastic limit	209MPA
Thermal conductivity	14.54w/mk
Heat input	350°c

Units:

TABLE 15

Unit System	Metric (mm, kg, N, s, mV, mA) Degrees rad/s Celsius
Angle	Degrees
Rotational Velocity	rad/s
Temperature	Celsius

TABLE 16: Model (A4) > Geometry

Object Name	<i>Geometry</i>
State	Fully Defined
<b>Definition</b>	
Source	E:\sanya\turbocasingthermalanalysisinputdata\technology\turbocasing\turbocasing\pump_of_turbo_engine3.stp
Type	Step

Length Unit	Meters
Element Control	Program Controlled
Display Style	Body Color
<b>Bounding Box</b>	
Length X	109. mm
Length Y	170.87 mm
Length Z	160.7 mm
<b>Properties</b>	
Volume	5.1095e+005 mm <sup>3</sup>
Mass	0. kg
Scale Factor Value	1.
<b>Statistics</b>	
Bodies	1
Active Bodies	1
Nodes	25639
Elements	14257
Mesh Metric	None
<b>Basic Geometry Options</b>	
Solid Bodies	Yes
Surface Bodies	Yes
Line Bodies	No
Parameters	Yes
Parameter Key	DS
Attributes	No
Named Selections	No
Material Properties	No
<b>Advanced Geometry Options</b>	
Use Associativity	Yes
Coordinate Systems	No
Reader Mode Saves Updated File	No
Use Instances	Yes
Smart CAD Update	No
Compare Parts On Update	No
Attach File Via Temp File	Yes
Temporary Directory	C:\Users\kishore\AppData\Local\Temp
Analysis Type	3-D

Mixed Import Resolution	None
Decompose Disjoint Geometry	Yes
Enclosure and Symmetry Processing	Yes

**Coordinate Systems:**

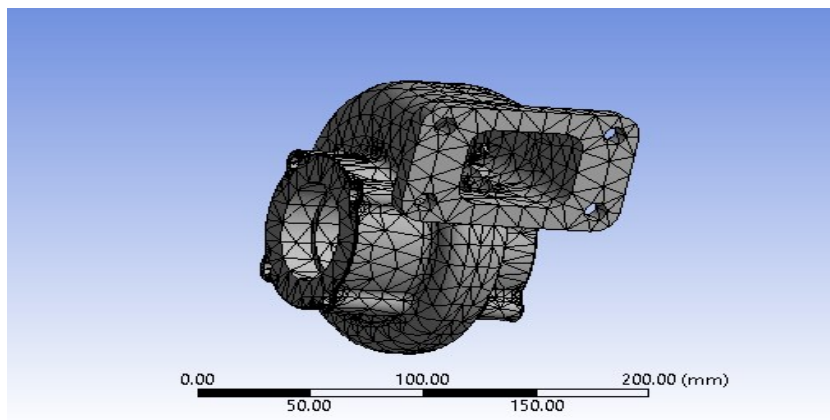

**Steady – State Thermal (A5):**

**TABLE 17: Model (A4) > Analysis**

Object Name	<i>Steady-State Thermal (A5)</i>
State	Solved
<b>Definition</b>	
Physics Type	Thermal
Analysis Type	Steady-State
Solver Target	Mechanical APDL
<b>Options</b>	
Generate Input Only	No

**TABLE 18: Model (A4) > Steady-State Thermal (A5) > Analysis Settings**

Object Name	<i>Analysis Settings</i>
-------------	--------------------------



State	Fully Defined
<b>Step Controls</b>	
Number Of Steps	1.
Current Step Number	1.
Step End Time	1. s
Auto Time Stepping	Program Controlled
<b>Solver Controls</b>	
Solver Type	Program Controlled
<b>Radiosity Controls</b>	
Radiosity Solver	Program Controlled
Flux Convergence	1.e-004
Maximum Iteration	1000.
Solver Tolerance	1.e-007 W/mm <sup>2</sup>
Over Relaxation	0.1
Hemi cube Resolution	10.
<b>Nonlinear Controls</b>	
Heat Convergence	Program Controlled
Temperature Convergence	Program Controlled
Line Search	Program Controlled
<b>Output Controls</b>	
Calculate Thermal Flux	Yes
General Miscellaneous	No
Store Results At	All Time Points
<b>Analysis Data Management</b>	
Future Analysis	None
Scratch Solver Files Directory	
Save MAPDL db	No
Delete Unneeded Files	Yes
Nonlinear Solution	Yes
Solver Units	Active System
Solver Unit System	mmm

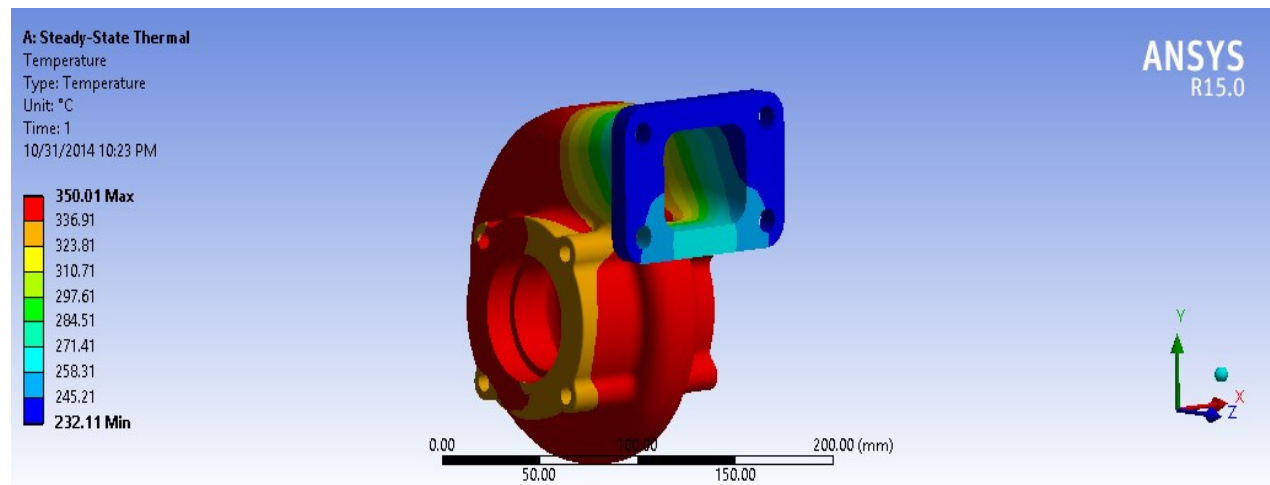
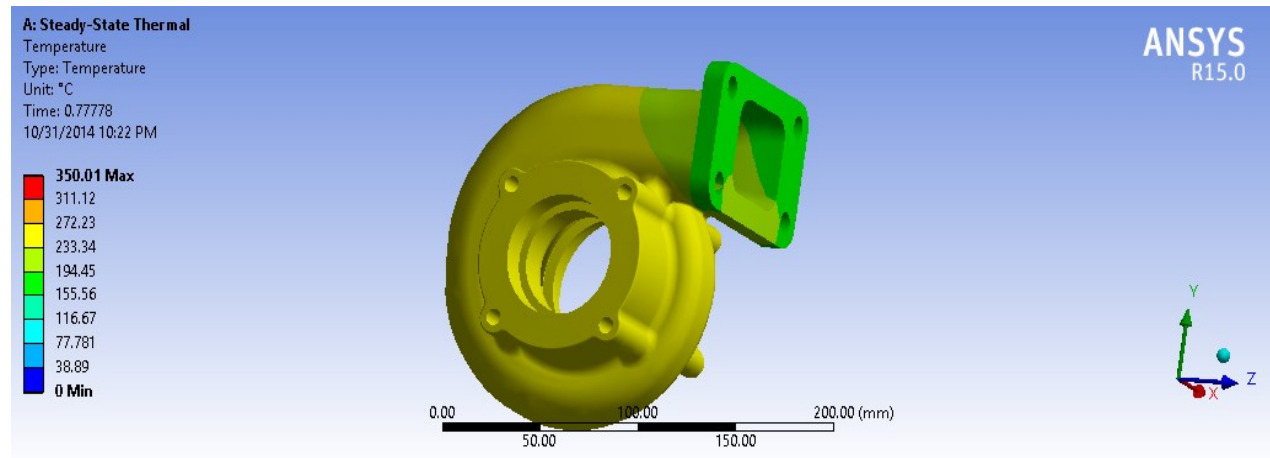
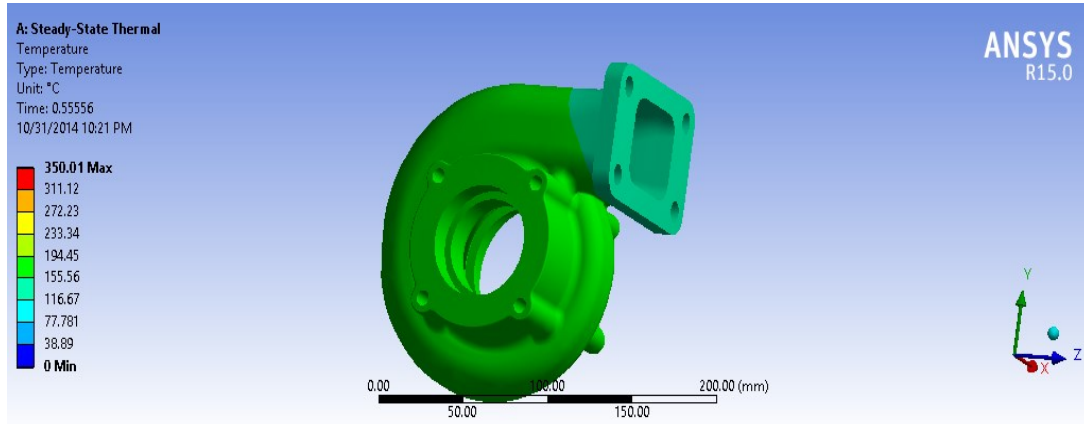

TABLE 19: Model (A4) > Steady-State Thermal (A5) > Convection

Temperature [°C]	Convection Coefficient [W/mm <sup>2</sup> ·°C]
1.	9.5e-007
10.	2.05e-006
100.	4.41e-006
200.	5.56e-006
300.	6.36e-006
500.	7.54e-006
700.	8.43e-006
1000.	9.5e-006

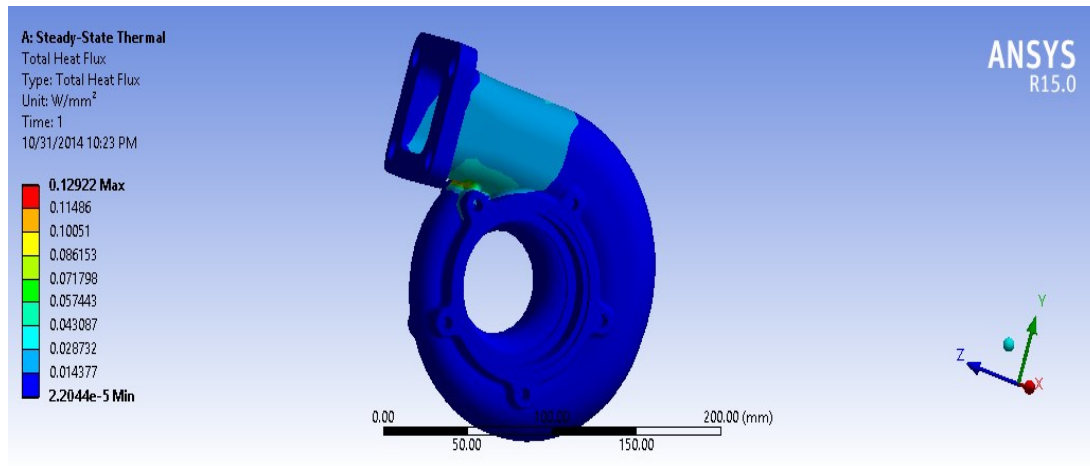
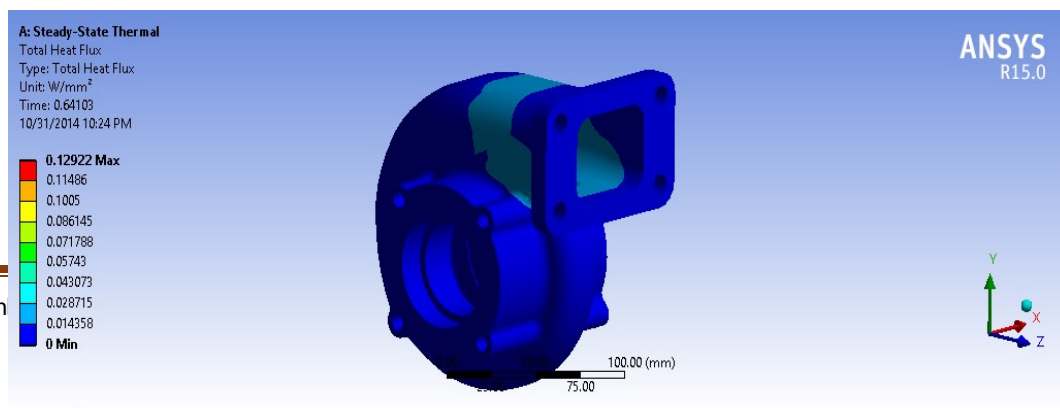
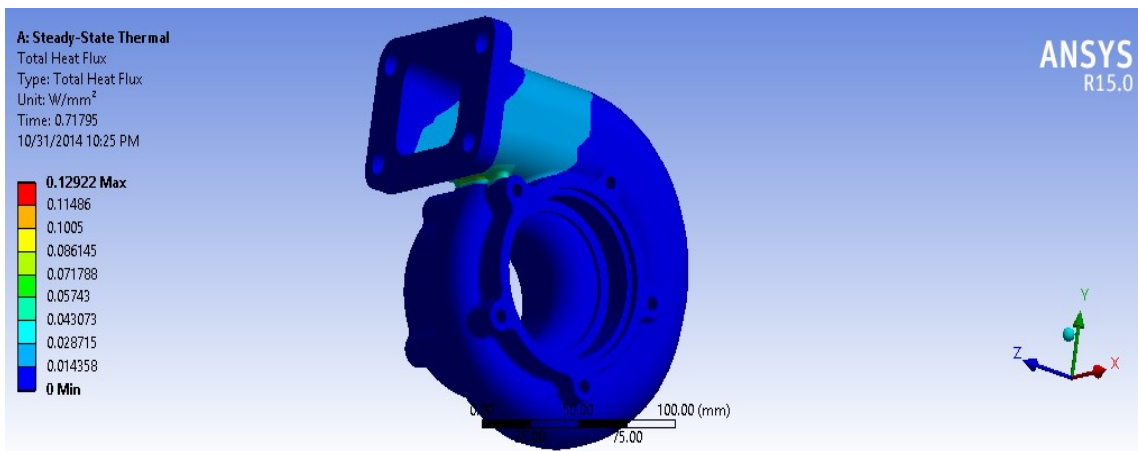

TABLE 20: Model (A4) > Steady-State Thermal (A5) > Solution (A6) > Results

Object Name	Temperature	Total Heat Flux
State	Solved	
<b>Scope</b>		
Scoping Method	Geometry Selection	

Geometry		All Bodies	
<b>Definition</b>			
Type	Temperature	Total Heat Flux	
By	Time		
Display Time	Last		
Calculate Time History	Yes		
Identifier			
Suppressed	No		
<b>Results</b>			
Minimum	232.11 °C	2.2044e-005 W/mm <sup>2</sup>	
Maximum	350.01 °C	0.12922 W/mm <sup>2</sup>	
<b>Minimum Value Over Time</b>			
Minimum	232.11 °C	2.2044e-005 W/mm <sup>2</sup>	
Maximum	232.11 °C	2.2044e-005 W/mm <sup>2</sup>	
<b>Maximum Value Over Time</b>			
Minimum	350.01 °C	0.12922 W/mm <sup>2</sup>	
Maximum	350.01 °C	0.12922 W/mm <sup>2</sup>	
<b>Information</b>			
Time	1. s		
Load Step	1		
Substep	1		
Iteration Number	3		



## Material Data

### Material 2

**TABLE 21: material 1 > Constants**

Thermal Conductivity	1.454e-002 W mm <sup>-1</sup> C <sup>-1</sup>
----------------------	-----------------------------------------------

## CONCLUSION

In this project we designed the outer case of a turbocharger for a diesel engine to increase its power and efficiency, and showing the advantage of designing of a turbocharger. In this project tends to usage of new materials is required. In the present work impeller was designed with three different materials. The investigation can be done by using Creo-2 and ANSYS software. The Creo-2 is used for modeling the impeller and analysis is done in ANSYS .ANSYS is dedicated finite element package used for determining the variation of stresses, strains and deformation across profile of the impeller.

### Material 1 : HK30Nb stainless alloy

Results		
Minimum	235.63 °C	2.2085e-005 W/mm <sup>2</sup>
Maximum	350.01 °C	0.13105 W/mm <sup>2</sup>
Minimum Value Over Time		
Minimum	235.63 °C	2.2085e-005 W/mm <sup>2</sup>
Maximum	235.63 °C	2.2085e-005 W/mm <sup>2</sup>
Maximum Value Over Time		
Minimum	350.01 °C	0.13105 W/mm <sup>2</sup>
Maximum	350.01 °C	0.13105 W/mm <sup>2</sup>

### Material 2: CF8C plus cast stain less steel

Results		
Minimum	232.11 °C	2.2044e-005 W/mm <sup>2</sup>
Maximum	350.01 °C	0.12922 W/mm <sup>2</sup>
Minimum Value Over Time		
Minimum	232.11 °C	2.2044e-005 W/mm <sup>2</sup>
Maximum	232.11 °C	2.2044e-005 W/mm <sup>2</sup>
Maximum Value Over Time		
Minimum	350.01 °C	0.12922 W/mm <sup>2</sup>
Maximum	350.01 °C	0.12922 W/mm <sup>2</sup>

So, by this **HK30Nb stainless alloy** is best material for the turbo casing design It have the bypass to control the air flow in the system which it will through the intercooler or release direct to the ambient.

## REFERENCES

- [1] C. Berrou, A. Glavieux, and P. Thitimajshima, "Near Shannon limit error-correcting coding and decoding: Turbo-codes," in ICC Proc., May 1993, pp. 1064–1070.
- [2] S. Benedetto and G. Montorsi, "Unveiling turbo codes: Some results on parallel concatenated coding schemes," IEEE Trans. Inform. Theory, vol. 42, pp. 409–429, Mar. 1996.
- [3] S. Benedetto, D. Divsalar, G. Montorsi, and F. Pollara, "Serial concatenation of interleaved codes: Performance analysis, design, and iterative decoding," IEEE Trans. Inform. Theory, vol. 44, pp. 909–926, May 1998.
- [4] L. C. Perez, J. Seghers, and D. J. Costello, Jr., "A distance spectrum interpretation of turbo codes," IEEE Trans. Inform. Theory, vol. 42, pp. 1698–1709, Nov. 1996.
- [5] O. Y. Takeshita and D. J. Costello, Jr., "New classes of algebraic interleavers for turbo-codes," in Proc. 1998 IEEE Int. Symp. on Information Theory, Cambridge, MA, Aug. 16–21, p. 419.
- [6] D. Divsalar and R. J. McEliece, "Effective free distance of turbo codes," Electron. Lett., vol. 32, no. 5, pp. 445–446, Feb. 1996.
- [7] O. Y. Takeshita, O. M. Collins, P. C. Massey, and D. J. Costello, Jr., "On the frame error rate of turbo-codes," in Proc. ITW 1998, Killarney, Ireland, June 22–26, 1998, pp. 118–119.
- [8] S. Benedetto, D. Divsalar, G. Montorsi, and F. Pollara, "Analysis, design, and iterative decoding of double serially concatenated codes with interleaves," IEEE J. Select. Areas Commun., vol. 16, pp. 231–244, Feb. 1998.