

Reduction of Harmonics by using Control of SVPWM for Shunt Active Filter with 3-Phase, 3-Wire Distribution system

M.KRISHNAM RAJU

M-tech Student Scholar

Department of Electrical & Electronics Engineering,
HELAPURI Institute of Technology & Science, Eluru,
West Godavari (Dt); A.P, India.

K.V.S.ANIL KUMAR

Assistant Professor

Department of Electrical & Electronics Engineering,
HELAPURI Institute of Technology & Science, Eluru,
West Godavari (Dt); A.P, India.

Abstract: As the use of power electronic equipment is spreading, the degradation of the power quality in the utility networks is increasing and is becoming a major problem. Limiting the current distortion is therefore a concern for both utilities and consumer. Power converters such as rectifiers, power supplies and at a higher power level, arc furnaces are the sources of harmonics. This harmonics can be reduced by using the shunt active filter. There are many control strategies to reduce harmonics. Advancement in semiconductor devices has fuelled an increase in the use of non-linear loads which are the main causes of harmonic distortion in three-phase, four-wire distribution systems. Mitigation of harmonics in three-phase, three-wire electrical power distribution systems that supply balanced and unbalanced non-linear loads was therefore conducted. In order to protect the supply system from current harmonics, we have to use the active power filters. The main aim of the proposed system is to compensate current unbalance, load current harmonics, load reactive power demand and load neutral current. Modulation technique used is Space Vector Pulse Width Modulation (SVPWM).

Keywords: Multilevel inverter, Shunt active power filter, P-O theory, Voltage source inverter, Current source inverter, Harmonics compensation.

I. INTRODUCTION

The growing use of non-linear and time-varying loads has led to distortion of voltage and current waveforms and increased reactive power demand in ac mains. Harmonic distortion is known to be source of several problems, such as increased power losses, excessive heating in rotating machinery, significant interference with communication circuits and audible noise, incorrect operation of sensitive loads [1]. Passive filters are traditional method to eliminate harmonics, but with recent developments in power semiconductor switches and converters, coupled with developments in control techniques and analog and digital implementations, active filters are becoming an effective and commercially viable alternative to passive filters. Active filter offer the following advantages: able to cover a wide range of harmonic frequencies; do not contribute resonant frequencies to the network; harmonic attenuation is network impedance dependent. Among the various topologies the shunt active power filter based on voltage source inverter (VSI) is the most

common one because of its efficiency [2-5]. The performance of active power filters depends on the adoptive control approaches. Various current detection methods, such as instantaneous reactive power theory, synchronous reference frame method. The commonness of these methods is the request for generating reference current of APF, either with the load current or the mains current. The commonness of these methods is to control VSI with the difference between real current and reference current [6-7].

The electric power quality has become an important part of the distribution power system. Harmonics are the primary cause for the poor power quality of the distribution system. Harmonics are qualitatively defined as sinusoidal waveforms having frequencies that are integral multiples of the power line frequency. In power system engineering, the term harmonic is widely used to describe the distortion for voltage or current waveforms [8-10]. The power line frequency (fundamental) is 50 Hz or 60 Hz. In case the fundamental frequency is 50 Hz, then 5th harmonic is 250 Hz, and 7th harmonics is 350 Hz, etc. Nonlinear loads are the main source of harmonic related problems. All electronic loads are mostly non-linear and generate harmonics in the power system.

These non-linear loads draw only short pulses of current from supply network and combine with the source impedance resulting in distortion of the supply voltage [11]. The modern power electronics provide suitable topology to mitigate the power quality problems the control scheme of shunt active power filter by using space vector pulse width modulation are used [12].

II. Classification of Active Power Filters

Mainly there are three types of active power filter:

Based on the converter type

1. VSI Inverter
2. CSI Inverter

Based on topology

1. Active Shunt Filter
2. Active series Filter

Hybrid filter

Based on supply system

1. 1-Phase-2 wire system
2. 3-Phase -3 wire system
3. 3-Phase-4 wire system

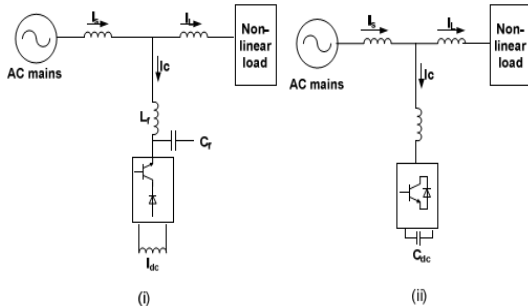

Fig.1 (i) CSC and (ii) VSC type shunt active power filter.

The main difference between these two topologies is energy storage element connected at DC link side. In CSC type shunt active power filter, the converter is formed by six controllable switches in series with diodes and $L_f C_f$ filter is connected in between the PWM converter and supply mains and it is used to suppress ripples in output of the converter. In VSC type shunt active power filter, the converter is formed by six controllable switches in shunt with diodes and L_f filter is connected in between the PWM converter and supply mains and it is used to suppress ripples in output of the converter [6]-[8]. This project presents the VSC type shunt active power filter. Basically the shunt active power filter is connected at point of common coupling, the basic principle of the active power filter is injected the reference harmonic currents in phase opposition to current harmonics produced by the non-linear loads. Due to that cancellation of current harmonics, we will get sinusoidal waveform at point of common coupling.

III.3-PHASE, 3-WIRE SAPF TOPOLOGY

A. Instantaneous real active and reactive power method:

The basic block diagram of 3-phase, 3-wire shunt active power filter is shown in Fig.2 [11]. Here the source is connected to the non-linear load, these non-linear loads always generates current harmonics. Due to these current harmonics, distorted waveform is appeared at point of common coupling. For getting sinusoidal waveform at point of common coupling we have to connect the shunt active power filter [7], [8]. These shunt active power filter consists of L_f filter and voltage source converter which is having six controllable switches in parallel with the diodes. Here the shunt active power filter takes the harmonic currents information from the nonlinear load, it gives the information to the PWM circuit, these PWM circuit generates the gating signals to the voltage source inverter. In the voltage source inverter, the switches are operating according to the generation of gating signals [9], [10].

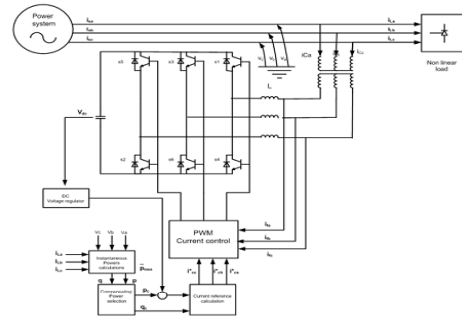

Fig.2 The basic block diagram of three phase three wire shunt active power filter.

The output of the voltage source inverter is passing through the L_f filter. These L_f filter is used to add the reference signals in phase opposition to the actual current harmonics generated by the non-linear load. These shunt active power filter can be operated with the help of real and reactive power control strategy.

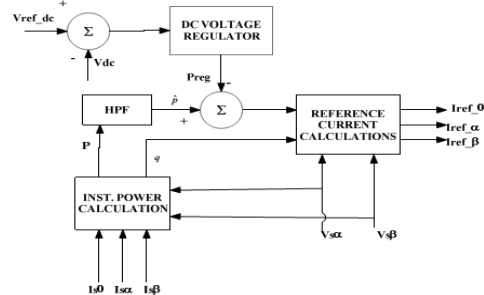

Fig.3 Active filter controller block diagram.

The operation of real and reactive power control strategy is based on active filter controller block diagram as shown in Fig.3. Former days the calculations of power flow were consequential from the average powers or root mean square values of voltages and currents. Akagi, H, proposed one method for calculating reference compensation currents called the instantaneous P-Q method (i.e., instantaneous real active and reactive power theory) [12]. These reference compensation currents are required to inject into the network, where nonlinear loads are connected. This P-Q theory is based on time domain analysis. By using of this P-Q theory, information of both load line currents and source voltages converters α - β -0 coordinates with the help of instantaneous power calculation [11]. So the P-Q theory has been used the transformation called Clarke transformation. It is used to plot the three phase supply/source instantaneous voltages and output/load line currents into α - β -0 coordinates. The transformation matrices C and C^{-1} for transformation of Clarke and back transformation are given respectively in equations.

$$\begin{pmatrix} V_{ino} \\ V_{inx} \\ V_{in\beta} \end{pmatrix} = C \begin{pmatrix} V_a \\ V_b \\ V_c \end{pmatrix} \quad (1)$$

$$\begin{pmatrix} V_{ino} \\ V_{inx} \\ V_{in\beta} \end{pmatrix} = \sqrt{2}/3 \begin{pmatrix} 1/\sqrt{2} & 1/\sqrt{2} & 1/\sqrt{2} \\ 1 & -1/2 & -1/2 \\ 0 & \sqrt{3}/2 & -\sqrt{3}/2 \end{pmatrix} \begin{pmatrix} V_a \\ V_b \\ V_c \end{pmatrix} \quad (2)$$

$$\begin{pmatrix} V_a \\ V_b \\ V_c \end{pmatrix} = C^{-1} \begin{pmatrix} V_{in0} \\ V_{in\alpha} \\ V_{in\beta} \end{pmatrix} \quad (3)$$

$$\begin{pmatrix} V_a \\ V_b \\ V_c \end{pmatrix} = \sqrt{2}/3 \begin{pmatrix} 1/\sqrt{2} & 1 & 0 \\ 1/\sqrt{2} & -1/2 & \sqrt{3}/2 \\ 1/\sqrt{2} & -1/2 & -\sqrt{3}/2 \end{pmatrix} \begin{pmatrix} V_{in0} \\ V_{in\alpha} \\ V_{in\beta} \end{pmatrix} \quad (4)$$

The equations (1), (2), (3), and (4) are shown above. These are given as voltage wave but they are also applicable for current waves. Here “0” represents the zero sequence component of voltage wave/current wave. In three phase three wire system, zero sequence components can't flow. So that zero sequence components, from above equations (1), (2), (3) and (4) are eliminated and the α - β axes transforming into three phase balanced -linear system.

$$\begin{pmatrix} P_r \\ Q_r \end{pmatrix} = \begin{pmatrix} V_{in\alpha} & V_{in\beta} \\ V_{in\beta} & -V_{in\alpha} \end{pmatrix} \begin{pmatrix} I_{op\alpha} \\ I_{op\beta} \end{pmatrix} \quad (5)$$

Rearranging equation (5)

$$\begin{pmatrix} I_{op\alpha} \\ I_{op\beta} \end{pmatrix} = \frac{1}{V_{in\alpha}^2 + V_{in\beta}^2} \begin{pmatrix} V_{in\alpha} & V_{in\beta} \\ V_{in\beta} & -V_{in\alpha} \end{pmatrix} \begin{pmatrix} P_r \\ Q_r \end{pmatrix} \quad (6)$$

$$P_r = \bar{P}_r + \tilde{P}_r \quad (7)$$

$$Q_r = \bar{Q}_r + \tilde{Q}_r \quad (8)$$

From equations (7) and (8), P_r be the instantaneous real power is the sum of average and oscillating real powers and Q_r be the instantaneous imaginary power is the sum of average and oscillating reactive powers. For linear load, P_r and Q_r are having only DC/constant/average values. However if load may be bridge rectifier as a non-linear load, the current waveform should enclose not only the 50 Hz/fundamental frequency component but also the multiple of 50 Hz/fundamental frequency components. Then the instantaneous P_r and Q_r should include constant dc or average component and fluctuating or oscillating component as decomposing in equations (7) and (8) The average component of real P_r and reactive Q_r can't to exist as reference powers so that oscillating components of real P_r and imaginary power Q_r must have to chosen as reference powers, if the shunt active power filter is deliberate for compensation current harmonics or circulating currents. From the active power filter controller block diagram, the low pass filter (LPF) is used to absorb the average/constant dc component/element and selecting the fluctuating/oscillating component/elements in equations (7) and (8) and back transformation is used to get the desire compensation reference currents (i_{ca}^* , i_{cb}^* , i_{cc}^*) in the form of a-b-c coordinates in Fig: 3.

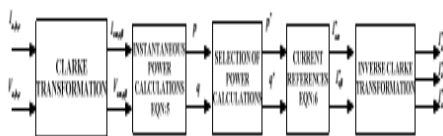

Fig.4. Calculation of current reference based on P-Q theory.

B. Importance of DC capacitor

The voltage of DC capacitor may be restricted by a DC voltage regulator. A low -pass filter is used it anesthetized to the fundamental (50 Hz) voltage frequency oscillations. The clean voltage variation occurs, according to the subsequent equations regulation of voltage (ϵ_r) is given as,

$$\epsilon_r = -1; \quad V_{dc} < -0.05V_{dc_ref} \quad (9)$$

$$\epsilon_r = \frac{V_{dc}}{-0.05V_{dc_ref}}; \quad -0.05V_{dc} \leq V_{dc} \leq -0.05V_{dc_ref} \quad (10)$$

$$\epsilon_r = 1; \quad V_{dc} > 0.05V_{dc_ref} \quad (11)$$

If $V_{dc} < V_{ref_dc}$; the pulse width Modulated inverter should be collect the energy from ac main to the dc capacitor. If $V_{dc} > V_{ref_dc}$; the pulse width modulated inverter should be carrying the energy from dc capacitor to ac main.

IV.CONSTRUCTION OF PI CONTROLLER

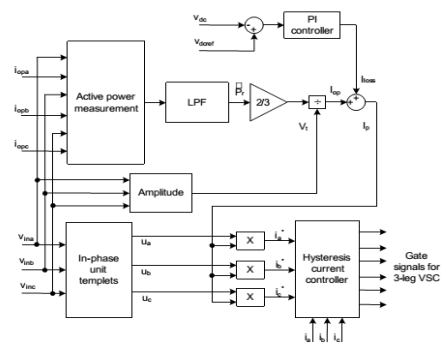

Fig.5 Generating gate signals for shunt active filter

The above Fig.5 shows that PWM control circuit of shunt active power filter based on generation of current references contains active power measurement, PI – controller, low pass filter, reference current generator and hysteresis (I_{opa} , I_{opb} , I_{opc}), the voltages at point of coupling (V_{ina} , V_{inb} , V_{inc}) and DC link voltage V_{dc} are sensed signals, and these are used as feedback signals. The bigger current references are getting as a result of modifiable the dc link voltage. The error signal is obtained from comparing the actual dc link voltage with V_{ref_dc} (reference DC voltage). The DC bus error voltage is given as

$$V_{dcerr} = V_{dc} - V_{dc_ref} \quad (12)$$

Here the PI – controller is used for DC bus control. So When the error signal is flowing by the way of PI controller, its controls the DC bus current signal, which will give the greater value of supply current included with the controller and is thus made accessible at zero crossing only. The output result of the PI controller is greater value of supply current that is the classified into of two elements/components. Those are

- (1). Fundamental element/component of active output/load current of SHAF and
- (2). Loss element/component of active output/load current of SHAF.

The greater value of the current is multiply with sinusoidal waveform in phase with input/source voltage to get compensating reference current waves. These compensating reference wave currents compared with the help of actual current waves in the hysteresis band, which will give the slipup signal to the modulation technique [5], [6]. Then this error signal will choose the action of voltage source inverter switches, these are generates the reference harmonic currents injected with the help of voltage source inverter.

V. Space Vector Pulse width Modulation

The basic idea of voltage space vector modulation is to control the inverter output voltages so that their Parks representation will be approximately equals the reference current vector. In the case of two level inverter, the output of each phase will be either $+V_{dc}/2$ or $-V_{dc}/2$. The SVM technique can be easily extended to all balanced and unbalanced loads. Space-vector PWM methods generally have the following features: good utilization of dc-link voltage, low current ripple, and relatively easy simulation implementation by a digital signal processor (DSP). These features make it suitable for high-voltage high-power applications. As the number of levels increases, redundant switching states and the complexity of selecting switching states increases dramatically.

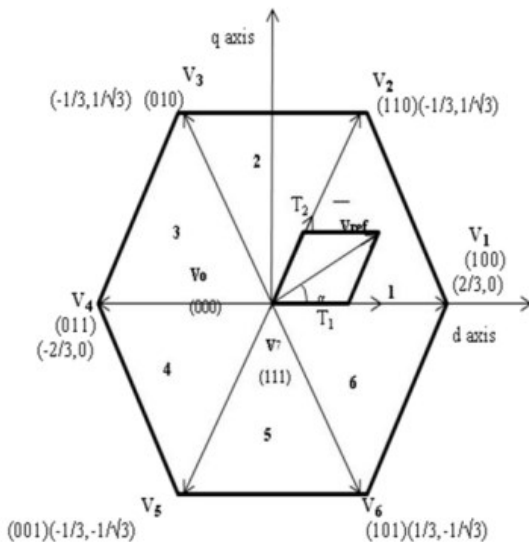

Figure.6. Basic switching vectors and sectors.
 Table 1.

Switching Table for space vector Modulation

Voltage Vector s	Switching Vectors			Line to Neutral Voltage			Line to Line Voltage		
	a	b	c	V_{an}	V_{bn}	V_{cn}	V_{ab}	V_{bc}	V_{ca}
V_0	0	0	0	0	0	0	0	0	0
V_1	1	0	0	$2/3$	$1/3$	$-1/3$	1	0	-1
V_2	1	1	0	$1/3$	$1/3$	$-2/3$	0	1	-1
V_3	0	1	0	$-1/3$	$2/3$	$-1/3$	-1	1	0
V_4	0	1	1	$-2/3$	$1/3$	$1/3$	-1	0	1
V_5	0	0	1	$-1/3$	$-1/3$	$2/3$	0	-1	1
V_6	1	0	1	$1/3$	$-2/3$	$1/3$	1	-1	0
V_7	1	1	1	0	0	0	0	0	0

VI. MATLAB/SIMULINK RESULTS

Case 1: 3-phase 3-wire balanced source

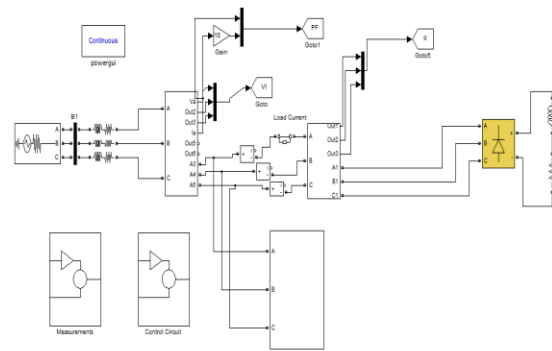

Fig.7. Simulink circuit for balanced 3-phase 3-wire system

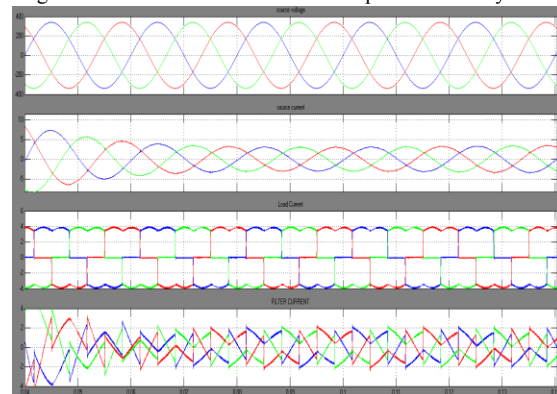

Fig.8. Simulation results for balanced system.

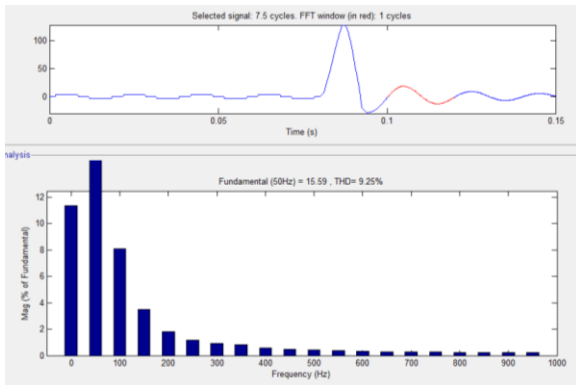

Fig.9. FFT analysis for source current.

Case 2: 3-phase 3-wire unbalanced source

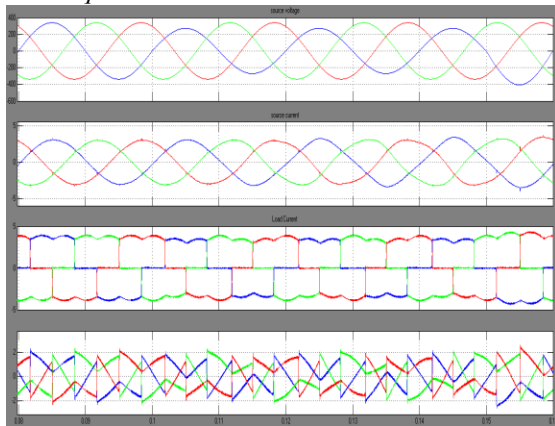

Fig.10. Simulation results for unbalanced system.

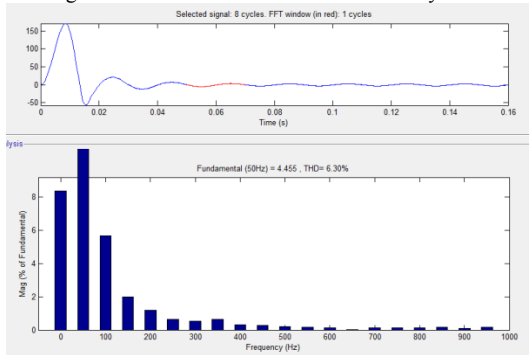

Fig.11. FFT analysis Source Current.

Case 3: 3-phase 3-wire non sinusoidal source

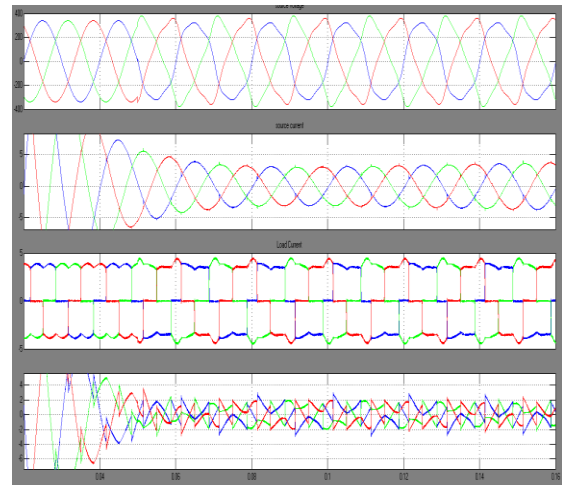

Fig.12. Simulation results for non sinusoidal source.

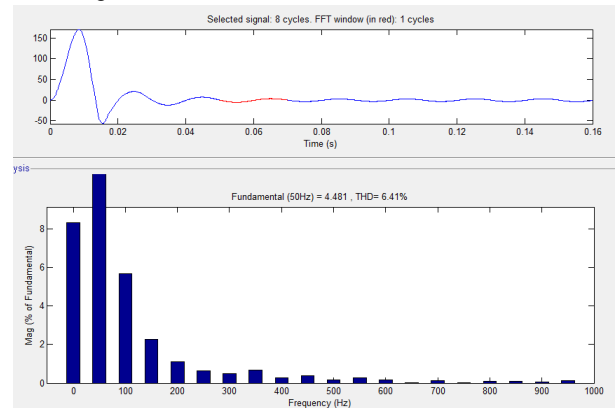

Fig.13. FFT analysis for source current.

Case 4: balanced three phase with dynamic load changes.

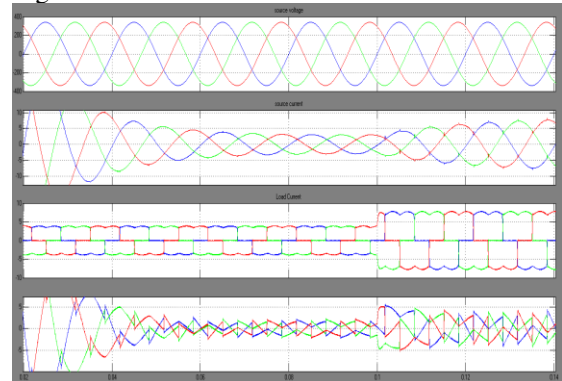

Fig.14. Simulation results for balanced three phase with load changes.

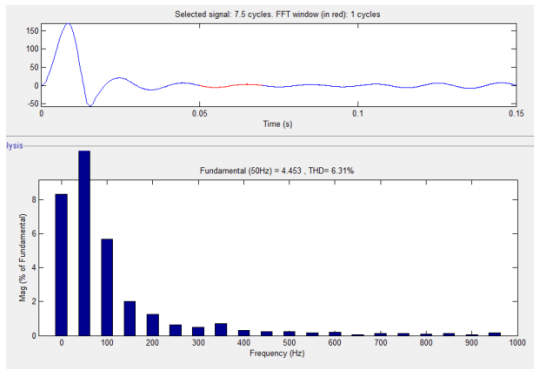

Fig.15. FFT analysis for Source Current.

Case 5: unbalanced three phase with dynamic load changes.

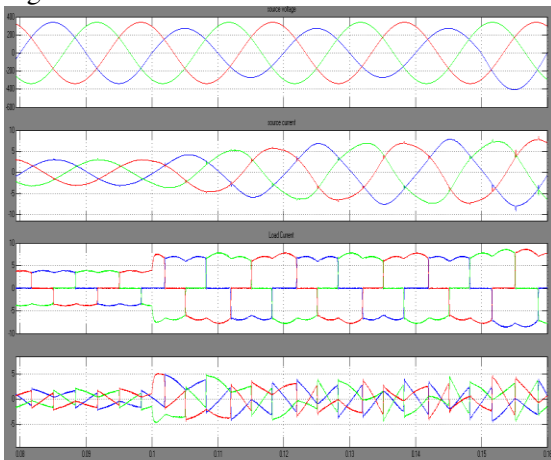

Fig.16. Simulation results for unbalanced three phase with load changes.

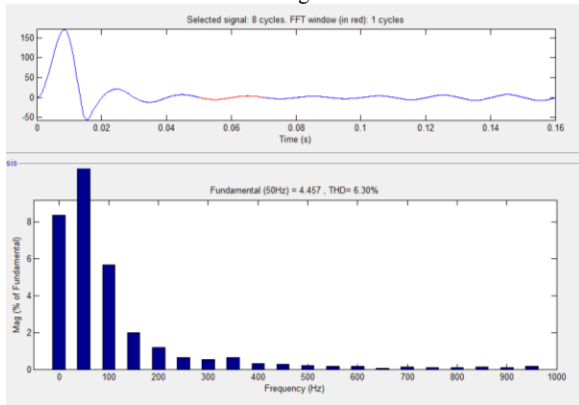

Fig.17. FFT analysis for source current

Case 6: non sinusoidal three phase with dynamic load changes.

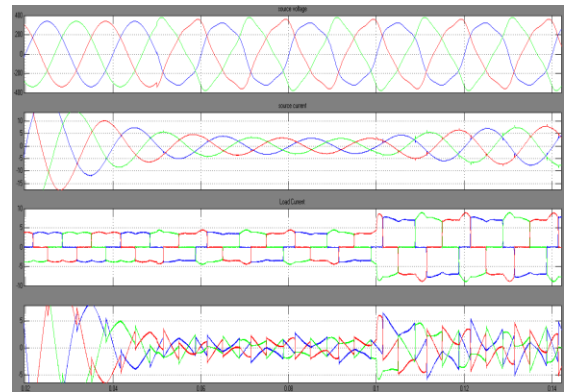

Fig.18. Simulation results for non sinusoidal three phase with load changes.

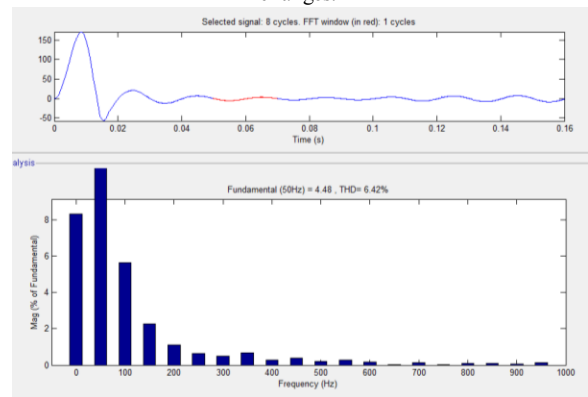

Fig.19. FFT analysis for source current.

Case 7: SVPWM based balanced load

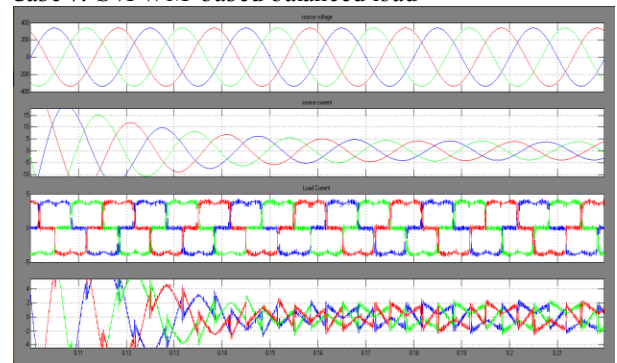

Fig.20. Simulation results for SVPWM based balanced load.

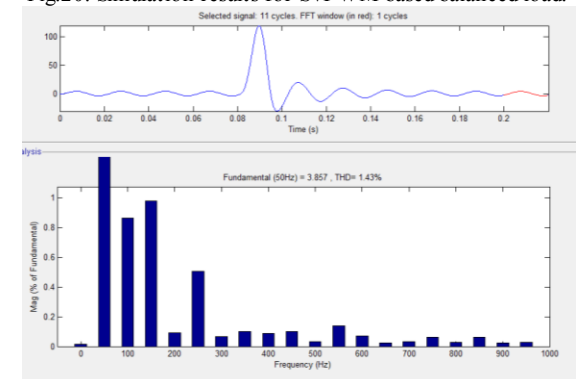

Fig.21. FFT analysis for source current.

Case 8: SVPWM based unbalanced load

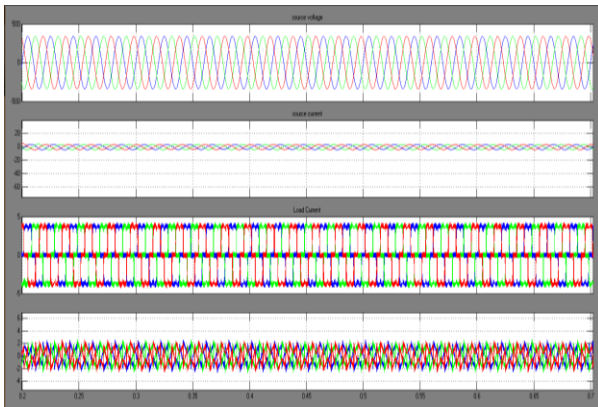

Fig.22. Simulation results for SVPWM based unbalanced load.

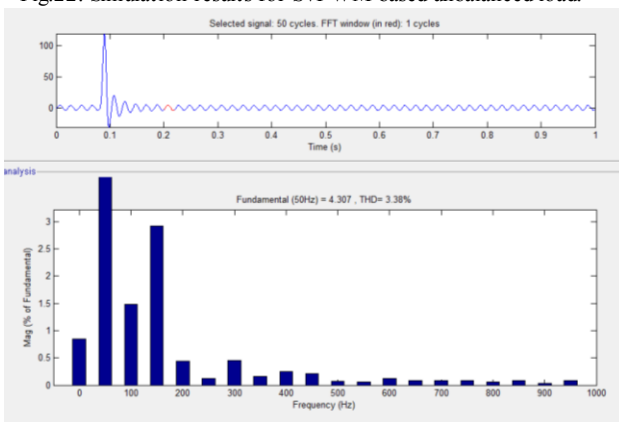

Fig.23.FFT analysis for source current.

VII. CONCLUSION

This paper presents a three phase three wire shunt active power filter as a reliable and cost-effective solution to power quality problems. When the active filter is installed at a distorted and unbalanced distribution network, the harmonic are compensated by the active filter. Therefore, the source needs to supply only balanced, sinusoidal currents which are in-phase with balanced positive-sequence fundamental voltage. This was useful to get the constant power supply and sinusoidal current waveform at point of common coupling. This construction of three phase three wire shunt active power filter with PQ theory is cost effectiveness for allowing more number of low pass filters to removing the reactive currents, circulating currents, neutral/zero sequence currents and improving the power factor at input of the system. Source THD is reduced by using SVPWM balanced and unbalanced loads SAPF.

REFERENCES

- [1] H. Akagi "New trends in active filters for power conditioning,"IEEE Trans. Ind. Appl.,Vol. 32, No. 6, pp. 1312-1322, Nov./Dec.1996.
- [2] F. Z. Peng, G. W. Ott Jr., D. J. Adams, "Harmonic and reactive power compensation based on the generalized instantaneous reactive power theory for three-phase four-wire systems" IEEE Trans. Power Electron.,Vol. 13, No. 5, Nov. 1998.

- [3] Fang Zheng Peng and Akagi, (1990), "A New Approach to harmonic Compensation in Power Systems A combined System of Shunt Passive and Series Active Filters", IEEE Transactions on Industrial Applications, Vol. 26, pp-6-11.
- [4] IEEE Std. 519-1992, "IEEE Recommended Practices and Requirements for Harmonic Control in Electric Power Systems".
- [5] H. Akagi, Y. Kanazawa, A. Nabae,; "Generalize theory of the Instantaneous Reactive Power in Three-Phase Circuits", IPEC'83 - Int. Power Electronics Conf.,Tokyo, Japan,1983, pp.: 1375 1386.
- [6] H..R.silva, j.s.martins J.I. Afonso; "Active filters for power quality improvement" IEEE power Tech'2001, Porto,Portugal [18]10-13 sept.2001.
- [7] A.nab, H. akagi Y. kanazawa,; "Instantaneous Reactive Power Compensator Comprising Switching Devices without Energy Storage Components", IEEE Trans. Industry Applic., vol. 20, May/June 1984.
- [8] IEEE Std. 519-1981 "Guide for Harmonic Control and Reactive Power Compensation of Static Power Converter".
- [9] R.m. stephan, M. aredes, E.H.watanabe; "New concepts of Instantaneous Active and Reactive Powers in Electrical Systems with generic loads",IEEE Trans. Power Delivery,vol 1.: 8, no: 2, April 199 pp. 697-703.
- [10] Z. peng, G.Ott, and D.J. Adams; "Harmonic and Reactive Power Compensation Based on the Generalized reactive Power Theory for Three Phase Four Wire System", IEEE Transl. Power Electronics., vol.:13, no.:5, pp.: 1174-1181, N ov.1998.
- [11] Alfonsa j., Couto C.,Martin j., "Active Filters with Control based on the p-q theory", IEEE Industrial Electronics Society Newsletter vol.47, no: 3,sep 2000, ISSN:0746-1240, pp. .5-10.
- [12] Kawabata T, Y komastu: "Characterisits of three phase active power filter using Extension PQ theory" , Industrial Electronics, 1997.ISIE 1997,proceedings of the IEEE international symposium [17] on jul 1997.