

Automated System for Air Pollution Detection and Control in Vehicles

*K.VIGNA

**B.Prasanna Jyothi

*M.TECH Dept of ECE, AURORA'S RESEARCH AND TECHNOLOGICAL INSTITUTE

Warangal, Telangana.

**Assoc. Prof Dept of ECE, AURORA'S RESEARCH AND TECHNOLOGICAL INSTITUTE

Warangal, Telangana.

ABSTRACT:

Every vehicle has its own emission of gases, but the problem occurs when the emission is beyond the standardized values. The primary reason for this breach of emission level being the incomplete combustion of fuel supplied to the engine which is due to the improper maintenance of vehicles. This emission from vehicles cannot be completely avoided, but it definitely can be controlled. The aim of the project is to monitor and control the pollutants in the vehicle by using the pollution control circuit. This pollution control circuit consists of various sensors like smoke sensor,

temperature sensor and GSM, GPS kind of devices, and all of them are integrated and connected to a Controller. It is a real time work where a demo application has been made in which ARM 7 processor is used and a controller board is made where all these devices get integrated and work accordingly. The vehicle is controlled by this circuit. When a vehicle attains certain threshold pollution level then the engine gets automatically switched off and an SMS is generated and sent to the pre-defined number stored in the memory through the GSM module. The GPS module is used to

locate the vehicle position where it is halted. This paper demonstrates an effective utilization of technology by which we save our environment by controlling the pollution of vehicles.

KEYWORDS: Sensors, GSM, GPS and Controller.

I. INTRODUCTION

The incomplete combustion in the engine of a vehicle leads to emission of different gases contributing to increase in the pollution and adversely affecting the environment. Detection and control of these gases is an important area of work. This emission from vehicles cannot be completely avoided but, it definitely can be controlled. Now a day's accidents are common reason for deaths. These are critical things to control so here we come up with a concept to reduce pollution and detect the location of accident using GPS. As a solution to the above problems we aim to build an automated control system for emission level control of vehicle and accident place detection. Smoke detector is used to detect the carbon percentage in the smoke released by the vehicle due to combustion of fuel in it.

Smoke detector is fixed at the end of the exhaust of vehicle from where smoke is released into the environment.

The smoke detector detects carbon and gives it to the Microcontroller to check the maximum percentage of carbon content in the smoke released by vehicles. Temperature sensor can be used to sense the temperature in the vehicle. So the controller checks the percentage of carbon and temperature, if it exceeds the threshold level the system gets triggered and the engine comes to halt state and then it sends SMS about this to the nearby pollution control office through GSM.

II. LITERATURE SURVEY

Over the years, there have been several regulations made by the Government to control the emission from vehicles; most of them being unsuccessful at the same. The standards and the timeline for implementation are set by the Central Pollution Control Board under the Ministry of Environment & Forests. Bharat stage emission standards are emission standards instituted by the Government of India to regulate the output of air Pollutants from internal combustion engine equipment, including motor vehicles. The first emission

norms were introduced in India in 1991 for petrol and 1992 for diesel vehicles. These were followed by making the Catalytic converter mandatory for petrol vehicles and the introduction of unleaded petrol in the market. On April 29, 1999 the Supreme Court of India ruled that all vehicles in India have to meet Euro I or India 2000 norms by June 1, 1999 and Euro II will be mandatory in the NCR by April 2000. Car makers were not prepared for this transition and in a subsequent judgment the implementation date for Euro II was not enforced. The standards, based on European regulations were first introduced in 2000. Progressively stringent norms have been rolled out since then. All new vehicles manufactured after the implementation of the norms have to be compliant with the regulations. Since

October 2010, Bharat stage III norms have been enforced across the country. In 13 major cities, Bharat stage IV emission norms are in place since April 2010. In this paper, the semiconductor sensors have been used to detect the pollutant level of the vehicles. This Paper concentrates mainly on three blocks; smoke detector, microcontroller and fuel injector. The smoke detector detects the pollutants (CO, NO_x, etc.) continuously. The microcontroller compares the level of pollutants with the stipulated level allowed by the government. When the pollutant level exceeds the standardized limit, it sends a signal to the fuel injector. On receiving a signal from the controller, the fuel injector stops the fuel supply to the engine after a particular period of time.

III. BLOCK DIAGRAM AND DESCRIPTION

Block diagram of the Automated System for Air pollution monitoring and control in the vehicles

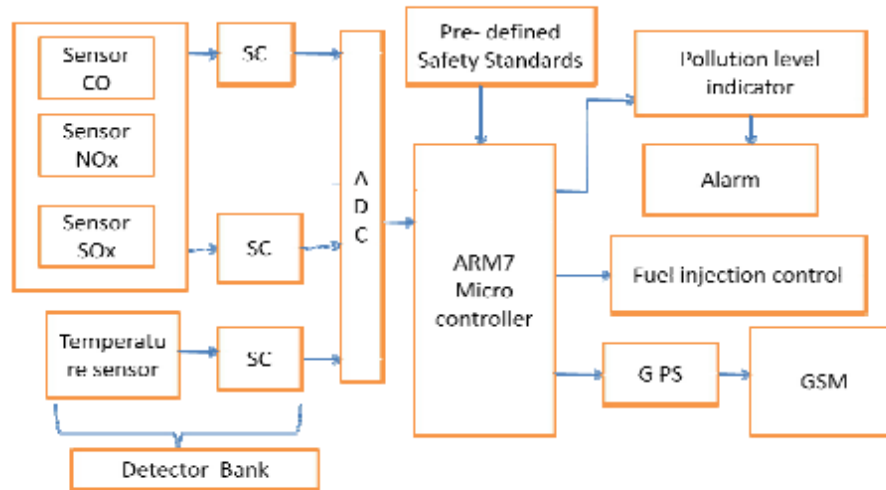

Figure: 1 schematic diagram of pollution monitoring

Semiconductor sensor MQ-2 is used to detect the smoke whose range is 300ppm to 10000ppm. LM35 temperature sensor monitors the engine temperature and prevents it from getting over heated.

III.EFFICIENT COMMUNICATION

The microcontroller is programmed to do mainly three functions namely: Comparison, timer and triggering. It takes two inputs one from the smoke sensor and the other being the pre-defined threshold value specified by the government. When the smoke sensor output is more than the threshold value, the microcontroller triggers the timer circuit and an alarm is set on to inform the driver of the pollution in the vehicle and that it will come to the halt state. Semiconductor sensor MQ-2 is used to detect the smoke whose range is 300ppm to 10000ppm. CO Sensor having

low conductivity in a clean environment is connected to an ARM7 micro processor. When this sensor is exposed to the pollutants its conductivity increases generating a signal in the circuit which disables the motor. An automatic SMS is also generated by a gsm module which is connected in the circuit. The vehicle location can be traced by GPS module and the location is sent to the pre-defined number stored in the memory.

Pre-defined values

POLLUTANT	PERMISSIBLE LIMIT
Nitrogen dioxide	60-80g/m ³
Carbon monoxide	2-4mg/m ³
Sulphur dioxide	60-80g/m ³

GPS is used to trace the position. GPS receiver gets the information of the location from satellites. In our project we used Model Pro Gin SR87 which tracks 27 Satellites. Global System for Mobile (GSM)

technology is used to establish cellular connection (SIM900). It is used for transmitting mobile voice and data services. Sends message to the predefined mobile number.

IV. FUEL INJECTOR MODULE

The main function of the fuel injector is to cut the supply of fuel to the engine, when the pollution limit is breached.

The relay circuit shown in the figure.2

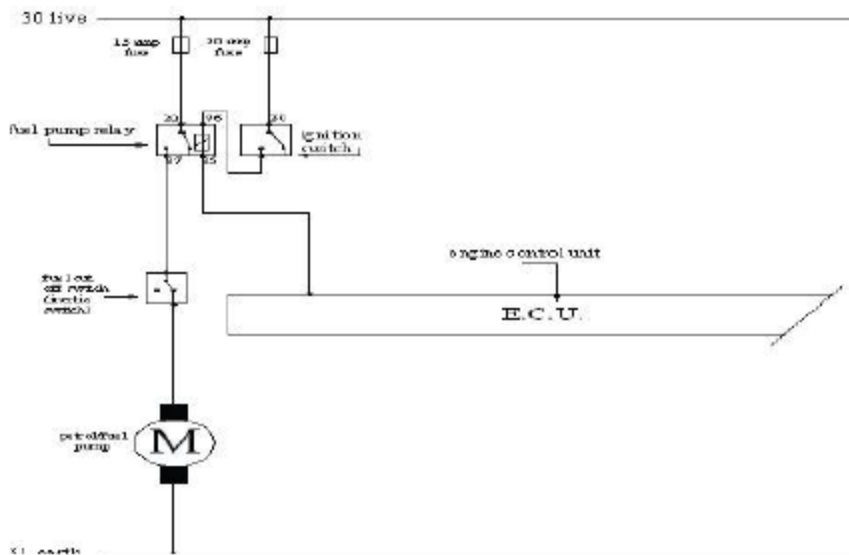

Figure: 2 Fuel pump wiring circuit

Fuel injector system work as a discontinuous control model (ON and OFF position) for fuel pump. Fuel injector system input is connected to the microcontroller and its output is connected to the Motor. The ignition switch is in the ON state when the pollutants are within limits. When the

pollutants cross the threshold values the ignition switch get turned OFF. When the ignition switch gets ON the engine control unit starts i.e. the engine will start there by the Fuel pump relay gets excited and hence the petrol pump run continuously without any disturbance. While the pollution

increases beyond the pre-defined value, then with the help of a 15Amp fuse the pump relay gets excited. In this paper, the engine control unit is programmed in such a way that, when the microcontroller sends a

trigger pulse after the timer runs out, relay should get back to its original position, that is the fuel cut off switch, is on. Then the fuel supply from

V. PROJECT OVERVIEW

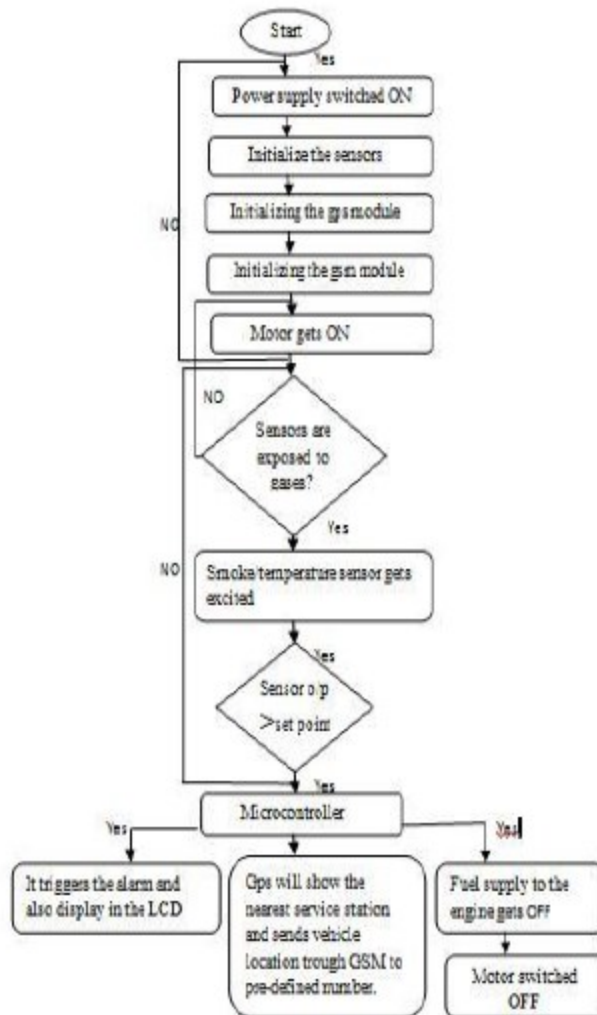

The signals acquired from the smoke sensor are compared with the user defined set point crossing the threshold limit the pollution

level gets displayed in the LCD and when it exceeds the set point it gives a buzzer indication following the motor gets off.

The table below shows the sample of results obtained from the system:

Pollution levels	Output voltage	Motor condition
300ppm	0V	ON
350ppm	0.5V	ON
400ppm	0.95V	ON
450ppm	1.35V	ON
500ppm	1.79V	ON
550ppm	2.30V	ON
600ppm	3.0V	ON
650ppm	3.45V	ON
700ppm	3.88V	ON
750ppm	4.4V	ON
800ppm	4.98V	OFF
850ppm	5.38V	OFF
900ppm	5.98V	OFF
950ppm	6.45V	OFF
1000ppm	7.0V	OFF

Table: 1 monitoring the pollution levels.

VII. CONCLUSION

The concept of detecting the level of Pollution and indicating it to the driver is implemented. There is an increase in the level of Pollution over the last couple of decades, leading to several Environmental problems. There will be a huge population,

who do not take care of the pollution from their vehicles seriously, which has already resulted in several environmental problems such as Ozone layer depletion and so on. Hence this system will be highly beneficial in curbing this problem.

REFERENCES

1.

http://wikipedia.org/wiki/Bharat_Stage_emi
ssion_standards

2. George F. Fine, Leon M. Cavanaugh, Ayo Afonja and Russell Binions " Metal Oxide Semi-Conductor Gas Sensors in Environmental Monitoring", Sensors 2010, 10, 5469-5502; doi:10.3390/s100605469

3. K. Galatsis, W. Wlodarsla, K. Kalantar-Zadeh and A. Trinchi "Investigation of gas sensors for vehicle cabin air quality monitoring," vol. 42, pp. 167-175, 2002.

4. "Trade of Motor Mechanic"; Module 5; Unit 2 Electronic Fuel injection; Phase 2 by FÁS Learning Innovation Unit with Martin McMahon & CDX Global; Curriculum Revision 2.2 16-01-07.

5. LIU Zhen-ya, WANG Zhen-dong, CHEN Rong, "Intelligent Residential Security Alarm and Remote Control System Based on Single Chip Computer," vol. 42, pp. 143-166, 2008

AUTHOR 1:-

* **K. VIGNA** completed her B tech in TALLA PADMAVATHI COLLEGE OF ENGINEERING in 2012 and completed M-

Tech (Embedded systems) in AURORA'S RESEARCH AND TECHNOLOGICAL INSTITUTE in 2015

Vigna457@gmail.com

AUTHOR 2:-

Mrs.B.Prasanna Jyothi
(M.Tech) is working as Assoc. prof in Dept of ECE, AURORA'S RESEARCH AND TECHNOLOGICAL INSTITUTE with 14 years of experience