

Reduced Switch Count Multilevel Inverter for Renewable Energy Source Application

T. SRIPAL REDDY
HOD, EEE

Department of Electrical & Electronics Engineering,
Sarada Institute of Tech. & Science, Khammam (Dt);
Telangana, India.

A. RAJA BABU
Assistant Professor

Department of Electrical & Electronics Engineering,
Sarada Institute of Tech. & Science, Khammam (Dt);
Telangana, India.

B. RAVI

M-tech Student Scholar
Department of Electrical & Electronics Engineering,
Sarada Institute of Tech. & Science, Khammam (Dt);
Telangana, India.

Abstract--This concept focus on one of the challenging and important situation of the all the countries around the globe i.e. remote areas rural electrification. In this concept, economical and reliable hybrid renewable energy system for remote areas has been implemented. The hybrid system uses a combination of solar and wind energy system as they are complementary and availability is plenty in nature. It can work in standalone mode or in hybrid mode depending on the availability of the sources. For the efficient utilization of the solar and wind energy, a modified PWM inverter with minimum components is used to obtain high quality output ac power that can feed directly the loads in remote areas. Direct drive PMSG, MPPT control, the modified PWM inverter with minimum power electronics, feeding ac and dc loads makes the system more economical, reliable for the remote areas electrification. MATLAB/Simulink software is used for the modeling and simulation of the hybrid energy system. The implemented hybrid energy system is used to generate and distribute power among the remote areas as the solar energy and wind energy are plenty in nature. Depending on the availability of the solar and wind energy, this system feeds the loads in standalone mode or hybrid mode. The proposed concept is implemented to 7 levels, 9 level multilevel inverter

Keywords— *Hybrid System; Solar energy system; wind energy system; Remote areas; modified PWM inverter*

I INTRODUCTION

The advancement in technology around the world has been increased in the past decade and seen tremendous changes/development in all aspects. The governments all over the world are struggling to supply the electricity as per the increased demand and taking it as challenge. The following reasons: mostly the electricity generation is with depleting fossil fuels, global warming due to carbon emissions, ozone layer depletion, ever increasing population and energy consumption, increased awareness of environmental protection, centralized power system that can't supply power to the remote areas etc.. drive the world to search for the alternate sources for the

power generation i.e renewable energy sources like solar, wind, tidal, biomass, geothermal energy, etc... The literature suggests that the plenty of energy can be extracted through sunlight, even wind also helps for the same. The conventional centralized energy system is confined to supply power to major cities, some part of urban areas and almost remote & island locations are neglected. Most of the people in the remote areas have no access to electricity; the idea of renewable energy system uses the concept of decentralization which in interest of efficient utilization of available energy sources and produced electricity is supplied to that particular area. So every corner of the world has chance to have the electricity. [1]

Wind and solar energy are the most promising clean renewable energy sources and are well suited for the remote area due to availability of heavy wind and plenty of sunlight. Generation of electricity through solar has many advantages as solar PV cell can directly produce electricity from sunlight, freely available, pollution free, guarantee for long life and the wind energy system is nonpolluting, less complexity as new designs are available with advancements in power electronics. But, generation of electricity based on standalone wind or standalone can't provide continuous power supply to the loads due to their uncontrollable intermittent nature, solar depends on irradiance, temperature, cannot supply electricity during nights and in case of wind energy- the direction and speed of wind is frequently changes. Combination of wind and solar will give good results as both are complementary in nature, continuous supply can be possible.

In this work cost effective and reliable hybrid renewable energy system for the remote areas has been implemented and it uses solar energy system consists of PV array, boost converter with MPPT control and wind energy system having wind turbine, PMSG and uncontrolled rectifier, and modified PWM Inverter based H-bridge which are discussed in the following sections.

II HYBRID RENEWABLE ENERGY SYSTEM FOR RURAL AREAS

The demand for energy in the past decade is continuously increasing as well as the raw material required to generate the electricity using conventional techniques are depleting, as a result alternate methods to be found to generate electricity. Traditionally centralized power plants are used to generate power. The transmission and distribution of the electricity to remote areas are difficult and costly, so the need for renewable energy system (RES) came to existence because plenty of wind energy and solar energy is observed in the remote areas where the generation and utilization of the electricity can be done, this is decentralization which in turn has advantage to generate more electricity with very less cost as we don't need transmission and have decreased losses. But the reliability of these systems is not up to the mark as they are uncontrolled and we cannot predict their nature. Hybrid Renewable Energy Systems (HRES) has more reliability; the HRES system uses combination of two or more renewable energies. In our paper, hybrid system shown in Fig.1 consists of Wind and Solar RES as they are complementary in nature. The following sections will provide modeling of different blocks of implemented hybrid system.[4]

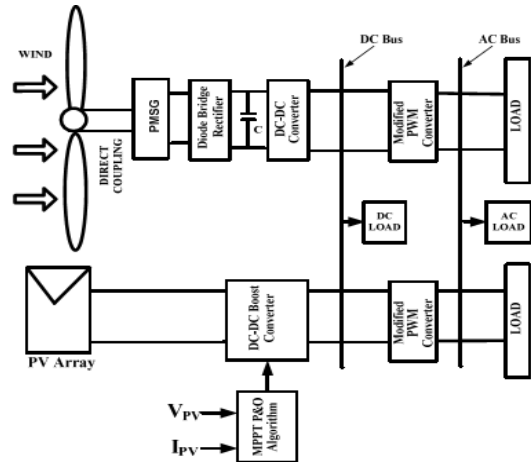

Fig.1. Block diagram of Implemented Hybrid System with Modified PWM converter Topology.

1 Solar Energy system

The basic blocks of the solar energy system are shown in the hybrid system Fig.1. It consists of PV array, DC-DC boost converter stage, and modified DC-AC PWM converter stage with minimum power electronic switches followed by load. The load may be dc or ac load. For the dc load, PV is connected to the load through dc-dc boost converter where as in case of ac load, connected through DC-DC-AC power conversion stage. The Photo Voltaic (PV) cell converts the radiation or heat from the sun into electrical energy. Solar cell has non-linear relation between the output current and output voltage as given in (1) and output power changes with temperature and irradiation.

$$I = I_{Ph} - I_D - I_{Sh}$$

$$I_{Sh} = \frac{V + I * R_{Se}}{R_{Sh}}$$

$$I_D = I_0 \left[\exp\left\{ \frac{q(V + I * R_{Se})}{AKT} \right\} - 1 \right] \quad (1)$$

Fig.2 shows the most commonly used single-diode equivalent circuit model of PV cell and it is parallel combination of the current source, diode and a shunt resistance; the value of the shunt resistance is of very

high order. Resistance R_{se} is connected in series and is of small value. Where, I_{ph} is photocurrent, I_D is diode current, I_o is reverse saturation current, A is ideality factor, q is charge of electron, K is Boltzmann's constant, T is cell temperature, R_{se} is series resistance, R_{sh} is shunt resistance, I is cell current, V is cell voltage.

As the conversion efficiency of PV cell is low, we have to use more PV modules in series or parallel to obtain the required voltage or current and the output dc voltage can be increased by using suitable power converter such as dc-dc boost converter (IGBT is used as switching device). The output of the boost converter can be directly given to the DC loads, for AC loads a DC-AC inverter is placed in between the load and the boost converter, the detailed description about the DCAC inverted is discussed.

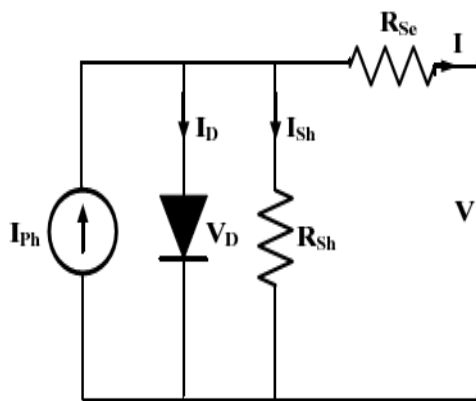

Fig.2. PV (Solar cell) modeling

In solar energy system, Maximum Power Point Tracking (MPPT) technique is used to get the maximum power from the PV cell as output power depends on solar irradiance and temperature. MPPT is a technique for boost converter, its duty cycle is adjusted in such a way that it draws the maximum amount of power from the system operate at MPP. Many algorithms are proposed in the literature and the most popular technique is perturb and observe (P&O) used in this paper for implementation. PV cell modeling, design of dc-dc boost converter with MPPT techniques, comparison of different MPPT techniques and P&O MPPT algorithm has been reported in the literature.

2 Wind Energy Systems

The advanced wind turbine designs and tremendous research developments in the field of power electronics made Wind energy as one of the best alternative source for power generation. And it features like clean, variable, environment friendly, huge availability makes as promising one. Wind energy system (WES) Fig.1 consists of the wind turbine, permanent magnet synchronous generator (PMSG), diode bridge rectifier, the modified PWM inverter followed by load. As mentioned in the above solar energy system; here also we can connect the DC load directly to the rectifier/dc-dc converter output, AC load is connected at the inverter output. With help of aerodynamically designed blades, the wind turbine captures power from the wind and converts kinetic energy into rotating mechanical energy that can be used to drive a PMSG. The power in (watts) captured by the wind turbine is given by

$$P_t = \frac{1}{2} \rho A C_p V W^3 \quad (2)$$

The mechanical torque in (N-m) is given by

$$T_M = \frac{P_M}{W_M} \quad (3)$$

Where, A is the wind turbine rotor swept area in (m^2), VW is the speed of the wind in (m/s), WM is the mechanical speed of the wind turbine in (rad/s), CP is the turbine power coefficient and ρ is the air density in kg/m^3 . Wind turbine may be fixed or variable speed type and its model selection depends on various factors like variation of wind, location and climate conditions. Good modeling, design and control provide the best possible results. A permanent magnet synchronous generator with a variable speed turbine provides maximum power with operating speed range. In this paper a multi-pole direct drive PMSG is used for the implementation and it is slow speed machine which has advantages like less weight, minimum losses, low cost and less maintenance because of no gearbox. This feature makes the implemented system highly reliable, efficient and cost-effective. The wind energy system design leads to more simple because of selection of PMSG as generator. As the output voltage and

frequency changes with generator speed, we have to use power electronic converter as a interface to feed the ac loads. Like in solar, here also we can use DC-DC converter with popular MPPT P&O technique to get continuously maximum power and can produce controlled dc output to feed dc loads directly.

The rectifier converts generator ac output to zero frequency dc components. The ripples in the rectifier output can be minimized by using capacitor filter. The dc link voltage that can be given to de loads or dc-ac inverter can be calculated as

$$V_o = \frac{(3\sqrt{2}) V_{rms}}{\pi} \quad (4)$$

Where, V_{rms} is the input ac line voltage and V_o is the output dc voltage. The dc-ac inverter is explained in the next section. Both the solar energy system and wind energy system can be used separately to connect to either AC or DC load, even the combined hybrid system can supply power to the load, so the system can be used individually if one of the system failed to deliver the electricity, the reliability of the system won't be effected further by using these renewable systems, the life span is around 25 years and guarantee is given to the system

III MODIFIED DC-AC INVERTER

In hybrid power system and stand alone renewable energy systems, power electronics technology plays a vital role in the interfacing wind/solar output to loads in remote areas. Good quality of output, minimum stress on switches, and maximum efficiency in medium and high power applications can be obtained by using multi-level inverters. The implemented system uses the modified DC-AC PWM inverter topology shown in Fig.3 to generate seven level output voltage. In general, to generate a seven level output waveform we require minimum of eight in case of H-bridges with unequal dc sources and twelve switches H-bridges with equal dc sources, considering the cost and reliability.

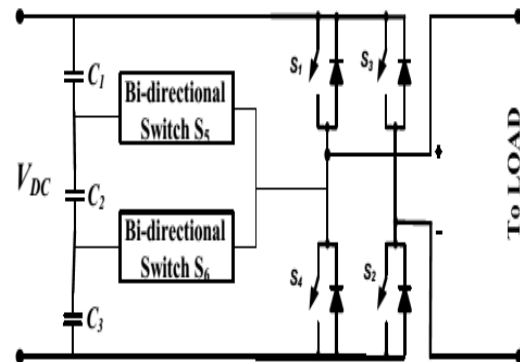

Fig.3. A single phase seven-level Modified PWM Inverter Implementing with a modified PWM inverter topology that uses only six switches. The system consists of a capacitor voltage divider, an H bridge and also a two bidirectional switches. In this paper we used a modified Pulse Width Modulating (PWM) technique. The system consists of a capacitor voltage divider, an H bridge and also a bidirectional switches. Switches are IGBTs with diode's. The triggering pulses for the six switches are generated by comparing three reference waves with the carrier wave. The reference signals and the carrier will have same magnitude and the frequency but each reference is shifted by value equal to carrier magnitude. The reference voltages are compared the carrier wave and firing pulses for the 6 switches are generated. The single H-bridge provides 3 level output. Remaining 4 levels (+V/3, +2V/3 and -V/3, -2V/3) are obtained by triggering S2 with S5&S6, S3 with S5&S6. The modified topology used for both standalone and hybrid systems that leads in low cost and less complexity.

IV MATALB /SIMULATION RESULTS

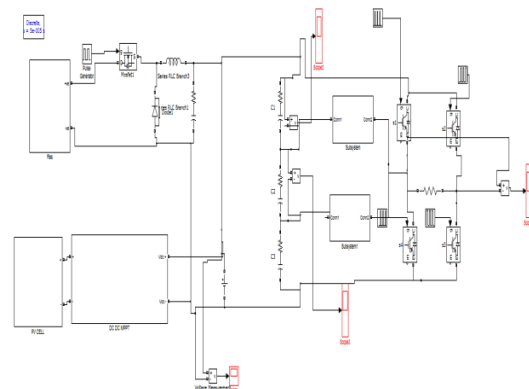

Fig 4 Matlab/Simulink conventional circuit of Implemented Hybrid System with Modified PWM converter Topology.

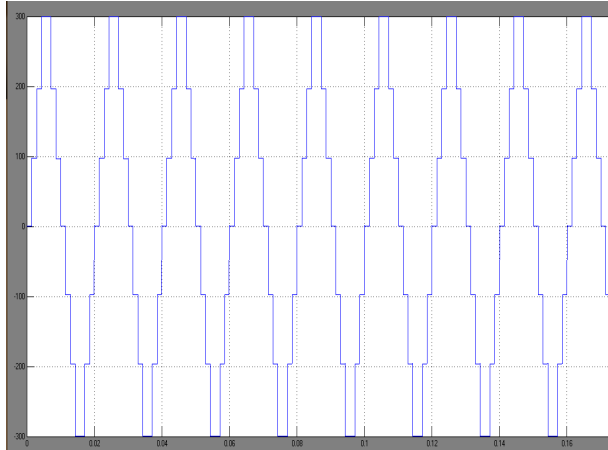

Fig 5 simulation wave form of conventional method seven level inverter

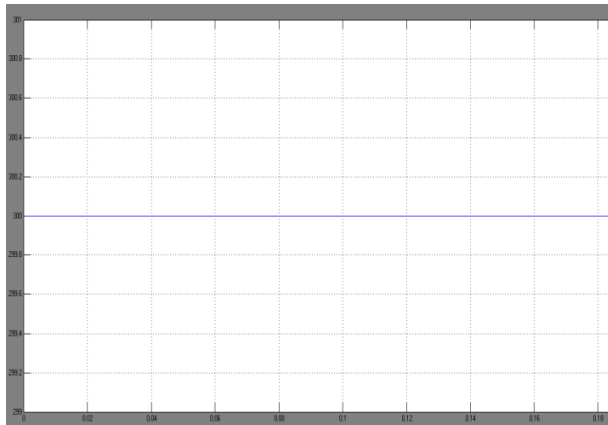

Fig 6 simulation wave form of conventional method PV array dc output

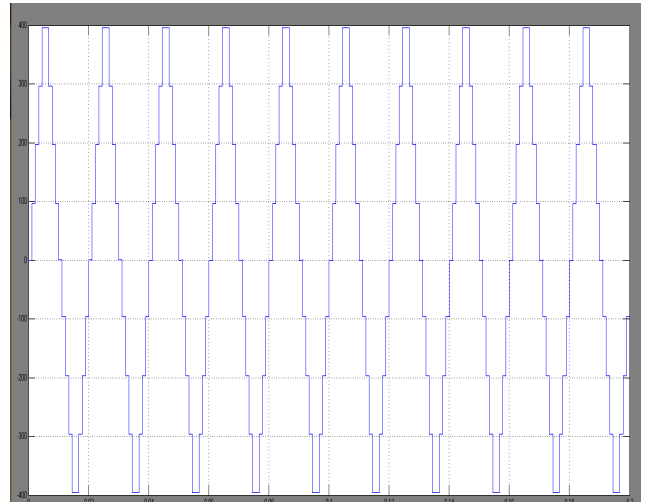

Fig 7 simulation wave form of proposed method of nine-level inverter

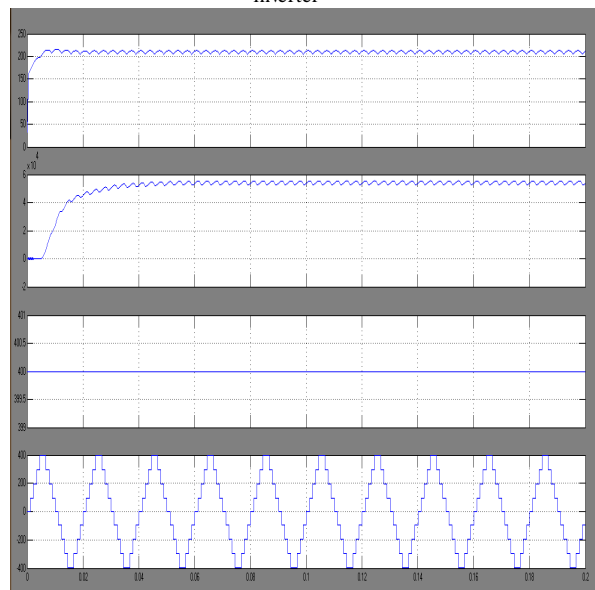

Fig 8 simulation wave form of proposed method of nine-level inverter output

CONCLUSION

The implemented hybrid energy system is used to generate and distribute power among the remote areas as the solar energy and wind energy are plenty in nature. Depending on the availability of the solar and wind energy, this system feeds the loads in standalone mode or hybrid mode. The implemented

system can be used to feed directly AC as well as DC loads without any grid connection. The modular structure of wind turbine-PMSG, Maximum Power Point Tracking control in dc-dc boost converter, simplified dc-ac inverter with modified PWM technique that generates seven level good quality of output with minimum power electronic switches, minimum THD and supplying both dc as well as ac loads makes the implemented system more reliable and cost effective in remote areas electrification.

REFERENCES

- [1] IEA, "World Energy outlook report," IEA, 2011
- [2] Chen Jian, Che Yanbo and Zhao Lihua, "Design and Research of Off grid Wind-Solar Hybrid Power Generation Systems," in *Proc. of 4th International Conference on Power Electronics Systems and Applications (PESA)*, pp. 1-5, Hong Kong, China, June 8-10, 2011.
- [3] Recayi pecen and Ahmet Nayir "Design and Implementation of a 12 kW Wind- Solar Distributed Power and Instrumentation System as an Educational Testbed for Electrical Engineering Technology Students" Modern electrical power system 2010, Wroclaw, Poland
- [4] A.M. Jain and Dr. B.E. Kushare "Techno-Economics of solar wind hybrid energy system in Indian context: A case study" Tamilnadu, pp 39 – 44, 2007.
- [5] Roberto Faranda and Sonia Leva " Energy comparison Techniques for PV system" *WSEAS transactions in power system*; vol.2, 2008.
- [6] Balasubramanian Indu Rani, Ganesan Saravana Ilango and Chilakapati Nagamani "Control Strategy for power flow management in a PV system supplying DC Loads" *IEEE Transactions on industrial electronics*; vol.6, 2013.
- [7] T. Eswar and P.L. Chapman, "Comparison of photovoltaic array maximum power point tracking techniques," *IEEE Transactions on Energy Conversion*, vol. 22, no. 2, 2007, pp. 439-449.
- [8] Teena Jacob and Arun S " Maximum Power Point Tracking of Hybrid PV and wind energy systems using a New Converter Topology," *ICGT*, pp 280 – 287, 2012.
- [9] Das.M, and Agarwal. V, "A Novel Control Strategy for Stand-alone solar PV System with Enhanced Battery Life," *APEC*, pp 2880 – 2887, 2014.
- [10] M. H. Nehrir, C. Wang, K. Strunz, H. Aki, R. Ramakumar, J. Bing, Z. Miao, and Z. Salameh, "A review of hybrid renewable/alternative energy systems for electric power generation: Configurations, control, and applications," *IEEE Trans. Sustain. Energy*, vol. 2, no. 4, pp. 392–403, Oct. 2011.
- [11] M. G. Villalva, E. Ruppert F. and J.R. Gazoli, "Analysis and simulation of the P&O MPPT algorithm using a linearized FV array model," *Industrial Electronics, 2009. IECON '09. 35th Annual Conference of IEEE*, 2009, pp. 231-236.
- [12] C. N. Bhende, S. Mishra, and S. G. Malla, "Permanent magnet synchronous generator based standalone wind energy supply system," *IEEE Trans.Sustain. Energy*, vol. 2, no. 4, pp. 361–373, Oct. 2011.
- [13] P. Samuel and N.Chandrashekhar, and R.Gupta, "Wind energy conversion based on seven-level cascaded H-bridge inverter using LabVIEW FPGA," in *Proc. Int. Conf. Power, Control and Embedded Syst. (ICPCES)*, pp. 1–6, 2010.
- [14] Mishra, S. ; Gupta, M. ; Garg, A. ; Goel, R. ; Mishra, V.K., "Modeling and simulation of Solar photo-voltaic and PMSG Based Wind Hybrid System," *SCEECS*, pp 1 – 6, 2014.
- [15] J. Moravek and P. Mastny, "Hybrid renewable energy system – configuration and control," *Recent Researches in Electric Power and Energy*, vol. 22, pp. 87–92, 2013.
- [16] Saeed Jahdi and Loi Lei Lai, "Grid integration of wind-solar hybrid renewable using AC/DC converters as DG power sources," *Proceedings of world congress sustainable technologies (WCST)*, 2011.
- [17] N. A. Rahim, K. Chaniago, and J. Selvaraj, "Single-phase sevenlevel grid-connected inverter for photovoltaic system," *IEEE Trans. Ind.Electron.*, vol. 58, no. 6, pp. 2435–2443, Jun. 2011.
- [18] H. Li, Z. Du, K. Wang, L. M. Tolbert, and D. Liu, "A hybrid energy system using cascaded H-bridge converter," in *Proc. IEEE Industrial Applications Conf.*, vol. 1, pp. 198-203, Oct. 2006.