

PFC and AC-DC Conversion Converter for Electric Vehicle Application

SEERA.NAGESWARA RAO
M-tech Student Scholar

Department of Electrical & Electronics Engineering,
Avanthi's St.The rissa Engineering College, Garividi;
Vizianagaram(Dt); Andhra Pradesh, India.

B.KALYANI M.TECH
Assistant Professor

Department of Electrical & Electronics Engineering,
Avanthi's St.The rissa Engineering College, Garividi;
Vizianagaram (Dt); Andhra Pradesh, India

Abstract- A new three-phase three-level single-stage power-factor corrected ac-dc converter with interleaved input has been proposed in this project. The converter operates with a single controller to regulate the output voltage and uses auxiliary windings taken from its power transformer as magnetic switches to cancel the dc bus voltage so that the input section operates like a boost converter. The proposed rectifier can produce input currents that do not have dead band regions with high PFC, operate with a continuous output current, and minimize the input electromagnetic interference filter size. The proposed converter can operate with lower peak voltage stresses across its switches and the dc bus capacitors as it is a three-level converter. It is more efficient because it has fewer diodes in the dc bus and it has less turn-on losses. The proposed topology implemented in extension the proposed concept can be implemented for electric vehicle application by using MATLAB/SIMULATION software and the results are verified

Keywords: Power Factor Correction, Single Stage Converters, AC-DC Power Factor Correction, Three Level Converters, Closed Loop Control Logic.

I. INTRODUCTION

Power-electronic converters are becoming popular for various industrial drives applications. In recent years also high-power and medium-voltage drive applications have been installed. To overcome the limited semiconductor voltage and current ratings, some kind of series and/or parallel connection will be necessary. Due to their ability to synthesize waveforms with a better harmonic spectrum and attain higher voltages, multi-level inverters are receiving increasing attention in the past few years. The ac-dc power supplies with transformer isolation are typically implemented with some sort of input power factor correction (PFC) to comply with harmonic standards such as IEC 1000-3-2 [2]-[4]. Although it is possible to satisfy these standards by adding passive filter elements to the traditional passive diode rectifier/LC filter input combination, the resulting converter would be very bulky and heavy due to the size of the low-frequency inductors and capacitors. The most common approach to PFC is to use two-stage power conversion schemes. These two-stage schemes use a front-end ac-dc converter stage to perform ac-dc conversion with PFC with the output of the front-end converter fed to a back-end dc-dc converter stage that produces the desired isolated dc output voltage

[5]. Using two converter stages in this manner, however, increases the cost, size, and complexity of the overall ac-dc converter, and this has led to the emergence of single-stage power-factor-corrected converters.

In order to reduce the cost, size, and complexity associated with two-stage ac-dc power conversion and PFC, researchers have tried to propose single-stage converters that integrate the functions of PFC and isolated dc-dc conversion in a single power converter. Several single-phase [6]-[12] and three-phase [5] converters have been proposed in the literature, with three-phase converters being preferred over single-phase converters for higher power applications. Previously proposed three-phase single-stage ac-dc converters, however, have at least one of the following drawbacks that have limited their widespread use.

- 1) They are implemented with three separate ac-dc single stage modules
- 2) The converter components are exposed to very high dc bus voltages so that switches and bulk capacitors with very high voltage ratings are required.
- 3) The input currents are distorted and contain a significant amount of low-frequency harmonics because the converter has difficulty performing PFC and dc-dc conversion simultaneously.
- 4) The converter must be controlled using very sophisticated techniques and/or nonstandard techniques [6]-[12]. This is particularly true for resonant-type converters that need variable-switching-frequency control methods to operate.
- 5) The output inductance must be very low, which makes the output current to be discontinuous. This results in a very high output ripple so that secondary diodes with high peak current ratings and large output capacitors to filter the ripple are needed.
- 6) Most of them are in discontinuous conduction mode at the input and need to have a large input filter to filter out large high-frequency harmonics [5].

II. THE SINGLE STAGE POWER FACTOR CORRECTED TOPOLOGIES

One classification of the SSPFC circuits is based on the number of switches in the converter. The SSPFC circuits provide the features of the power factor pre-regulators in

addition to those of dc-dc converters cascaded with it. The basic SSPFC circuit was introduced in early 1990s by Madigan. This was achieved by integrating the boost input shaping converter with either a fly-back or a forward topology.

A. Single switch topologies

Many single switch single stage converter topologies have been proposed. A single stage ac-dc converter is proposed in which the dc voltage is less dependent on the operating conditions. But the voltage stress is more on the switch. Also it contains low frequency output voltage ripples. The various problems associated with single switch topologies are lower power factor at low line input, dead angle problem of input current high capacitor voltage stress and higher switch voltage.

B. Two switch topologies

Half bridge converters have also been integrated in SSPFC topologies either in symmetrical or asymmetrical modes of operation. They are able to provide high input power factor. Still they suffer from high circulating currents, high dc bus voltages or discontinuous currents.

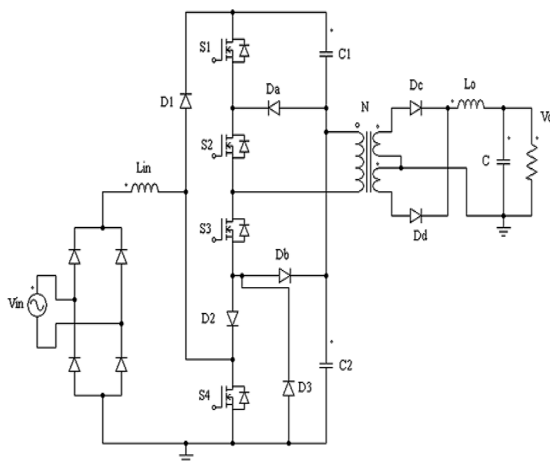

Fig.1 Three level single stage converter

The topology proposed in has an auxiliary circuit which is used to get a reduced capacitor voltage stress. Here the converter is operated in DCM, thus achieving high input power factor. But the current stress on the converter switches becomes high. Thus the conduction losses increase resulting in lower efficiency. Hence these converters cannot be used for higher power applications.

Fig.1 shows a new three level single stage converter which eliminates the limitations of the previous topologies. It consists of a boost converter section and an isolated forward converter section. The authors proposed a three-phase single-stage three-level converter to mitigate these drawbacks. Although the converter proposed in that paper was an advance over previously proposed three-phase single-stage converters, it still suffered from the need to

have a discontinuous output inductor current at light-load conditions to keep the dc bus capacitor voltage < 450 V, and it needed to operate with discontinuous input current, which resulted in high component current stress and the need for significant input filtering due to the large amount of ripple.

This paper presents a new interleaved three-phase single stage rectifier that does not have any of these drawbacks. The work presented in this paper can be considered to be a follow-up work in relation to what was presented. In comparison to the converter presented, the converter presented in this paper has an interleaved structure, requires two fewer diodes in the dc bus, has an output current which is continuous for all load ranges, has a dc bus voltage that is less than 450 V for all load conditions, and has a much better input current harmonic content. In this paper, the operation of the new converter is explained; its features and design are discussed.

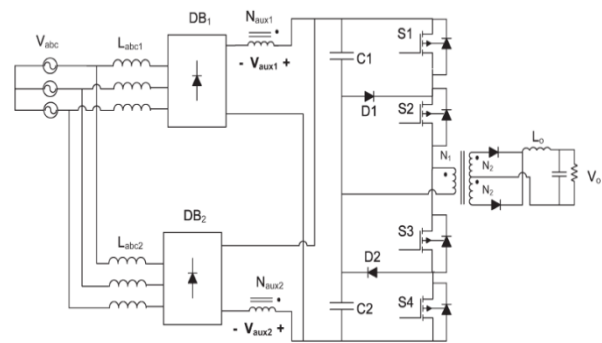

Fig.2 Proposed interleaved three-phase three-level converter

Several SSPFC topologies have been introduced so far by various power electronic researchers. In the next section a review of the various SSPFC topologies is being carried out.

II. PROPOSED CONVERTER OPERATION

The proposed converter and its key waveforms are shown in Figs. 2 and 3, respectively. The proposed converter uses auxiliary windings that are taken from the converter transformer to act as “magnetic switches” to cancel the dc bus capacitor voltage so that the voltage that appears across the diode bridge output is zero. When the primary voltage of the main transformer is positive, auxiliary winding 1 ($N_{aux1}/N_1=2$) cancels out the dc bus voltage so that the output voltage of diode bridge 1 (DB1) is zero and the currents in input inductors L_{a1} , L_{b1} , and L_{c1} rise. When the primary voltage of the main transformer is negative, auxiliary winding 2 ($N_{aux2}/N_1=2$) cancels out the dc bus voltage so that the output voltage of diode bridge 2 (DB2) is zero and the currents in input inductors L_{a2} , L_{b2} , and L_{c2} rise. When there is no voltage across the main transformer primary winding, the total voltage across the dc bus capacitors appears at the output of the

diode bridges and the input currents fall since this voltage is greater than the input voltage. If the input currents are discontinuous, the envelope of the input current will be sinusoidal and in phase with the input voltages. The converter modes of operation are explained in this section. The typical converter waveforms are shown in Fig. 3. The equivalent circuit in each stage is shown in Fig. 4. The converter goes through the following modes of operation.

Mode 1 ($t_0 < t < t_1$) [Fig. 4(a)]: During this interval, switches S1 and S2 are ON. In this mode, the energy from dc bus capacitor C1 flows to the output load. Due to magnetic coupling, a voltage appears across auxiliary winding 1 which is equal to the dc bus voltage but has opposite polarity and cancels the total dc bus capacitor voltage; the voltage at the diode bridge output is zero, and the input currents i_{La1} , i_{Lb1} , and i_{Lc1} rise.

Mode 2 ($t_1 < t < t_2$) [Fig. 4(b)]: In this mode, S1 is OFF, and S2 remains ON. The energy stored in L1 ($L1=Labc1$) during the previous mode starts to transfer into the dc bus capacitors. The voltage that appears across auxiliary winding 1 is zero. The primary current of the main transformer circulates through D1 and S2. With respect to the converter's output section, the load inductor current freewheels in the secondary of the transformer, which defines a voltage across the load filter inductor equal to $-V_L$.

Mode 3 ($t_2 < t < t_3$) [Fig. 4(c)]: In this mode, S1 and S2 are OFF. The energy stored in L1 still is transferring into the dc bus capacitor. The primary current of the transformer charges C2 through the body diodes of S3 and S4. Switches S3 and S4 are switched ON at the end of this mode.

Mode 4 ($t_3 < t < t_4$) [Fig. 4(d)]: In this mode, S3 and S4 are ON, and the energy flows from capacitor C2 into the load. The voltage appears across auxiliary winding 2 which is equal to the dc bus voltage but acts like a magnetic switch and cancels out the dc bus voltage. The voltage across the boost inductors L2 ($L2=Labc2$) becomes only the rectified supply voltage of each phase, and the current flowing through each inductor increases. This mode ends when the energy stored in L1 completely transfers into the dc bus capacitor. For the remainder of the switching cycle, the converter goes through modes 1-4 but with S3 and S4 ON instead of S1 and S2 and with DB2 instead of DB1.

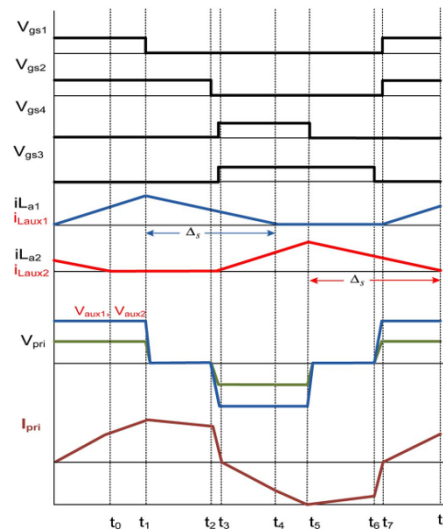
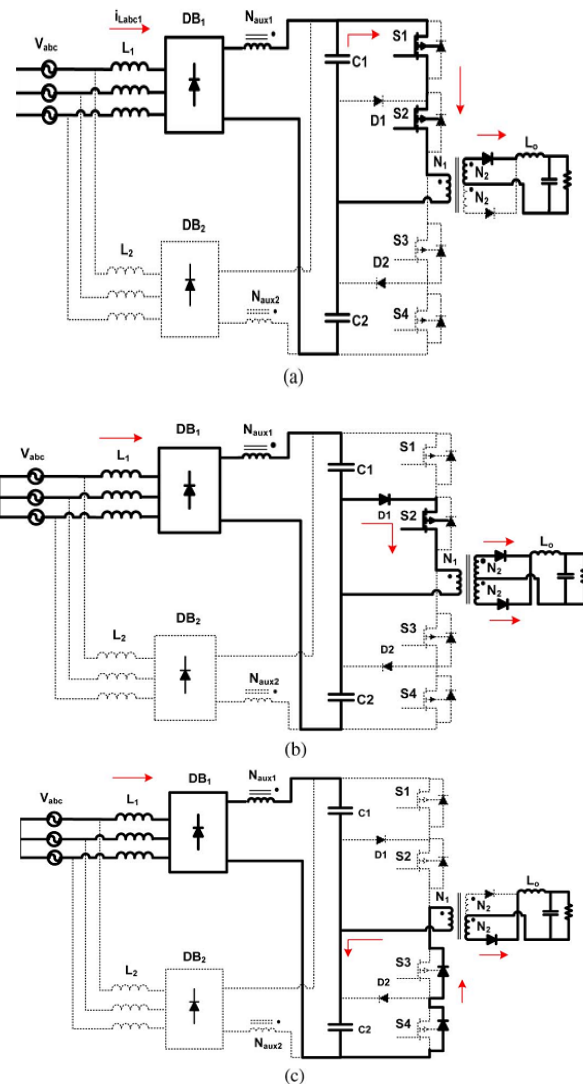

Fig.3 Typical waveforms describing the modes of operation



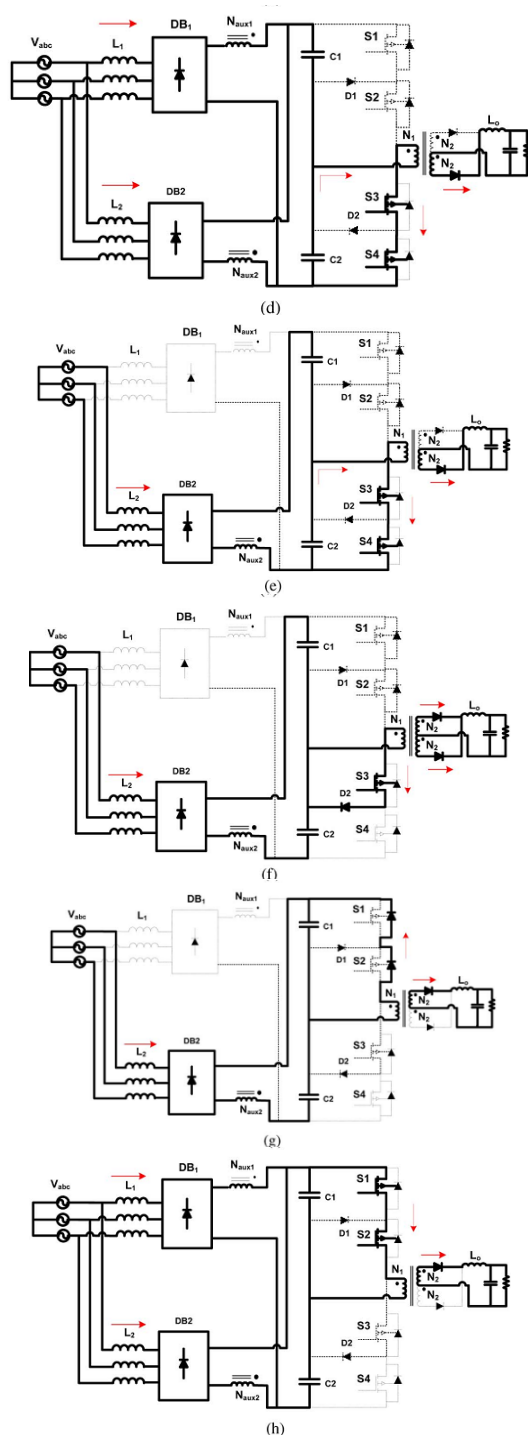

Fig. 4. Modes of operation. (a) Mode 1 ($t_0 < t < t_1$). (b) Mode 2 ($t_1 < t < t_2$). (c) Mode 3 ($t_2 < t < t_3$). (d) Mode 4 ($t_3 < t < t_4$). (e) Mode 5 ($t_4 < t < t_5$). (f) Mode 6 ($t_5 < t < t_6$). (g) Mode 7 ($t_6 < t < t_7$). (h) Mode 8 ($t_7 < t < t_8$)

Mode 5 ($t_4 < t < t_5$) [Fig. 4(e)]: In this mode, S3 and S4 are ON, and a symmetrical period begins. In this mode, the energy flows from capacitor C2 into the load. The voltage across the boost inductors L2 becomes only the rectified supply voltage of each phase, and the current flowing through each inductor increases.

Mode 6 ($t_5 < t < t_6$) [Fig. 4(f)]: In this mode, S3 is ON and S4 is OFF, and the primary current of the main transformer

circulates through diode D2 and S3. The energy stored in the boost inductors L2 during the previous mode starts transferring into the dc bus capacitor. The output inductor current also freewheels in the secondary of the transformer during this mode.

Mode 7 ($t_6 < t < t_7$) [Fig. 4(g)]: In this mode, S3 and S4 are OFF, and the primary current of the transformer charges capacitor C1 through the body diodes of S1 and S2. The energy stored in the boost inductors L2 transfers into the dc bus capacitor.

Mode 8 ($t_7 < t < t_8$) [Fig. 4(h)]: In this mode, S1 and S2 are ON. In this mode, the energy from dc bus capacitor C1 flows to the output load. This mode ends when the energy in the inductors L2 completely transfers into the dc bus capacitors. Time t_8 is the end of the switching cycle, and another switching cycle begins with the same modes

It should be noted that the input current is the summation of inductor currents i_{L1} and i_{L2} which are both discontinuous. However, by selecting appropriate values for L1 ($=L_{a1}=L_{b1}=L_{c1}$) and L2 ($=L_{a2}=L_{b2}=L_{c2}$) in such a way that two inductor currents such as i_{La} and i_{La2} have to overlap each other, the input current can be made continuous as shown in Fig. 5, thus reducing the size of the input filter significantly.

There is a natural 180° phase difference between the currents in L1 and the currents in L2 as one set of currents rises when the transformer primary is impressed with a positive voltage and the other set rises when the transformer primary is impressed with a negative voltage—these two events occur 180° apart during a switching cycle.

III. CONVERTER ANALYSIS AND DESIGN

The analysis and the design of the proposed interleaved converter are almost identical to that presented and therefore are not presented here. Readers are referred for details. In this paper, only differences in the analysis and the design are presented.

With respect to analysis, steady-state operating points are identified using a computer program such as the one presented. The only difference between the analysis of the proposed converter and the one is the analysis and design of the input inductors. In the proposed interleaved converter, there are two sets of inductors (L1 and L2) at the input side, with each set conducting half the current. The analysis needs to consider the current in both these sets instead of just one.

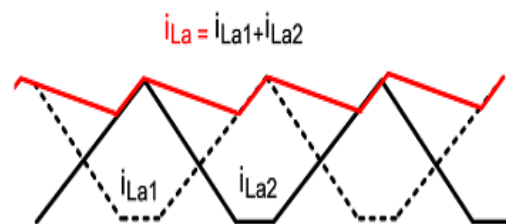

Fig.5 Interleaving between two input inductor currents

The values for L_1 and L_2 should be low enough to ensure that their currents are fully discontinuous under all operating conditions but not so low as to result in excessively high peak currents. The worst case to be considered is the case when the converter operates with minimum input voltage and maximum load since, if the input current in each set of inductors is discontinuous under these conditions, it will be discontinuous for all other operating conditions, and thus, an excellent power factor will be achieved.

IV. SIMULATION RESULTS

Case 1: Design of Open-Loop Circuit of Proposed AC-DC Converter

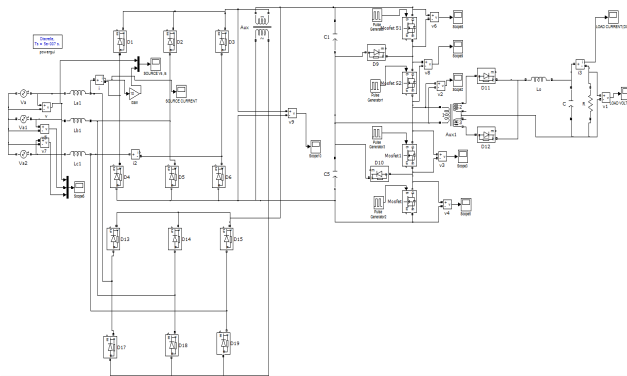

Fig.6 Matlab/Simulink model of proposed converter.

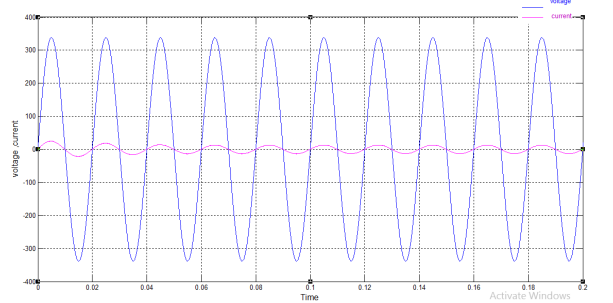

Fig.7 Simulated input wave form of the Voltage and current of the proposed converter.

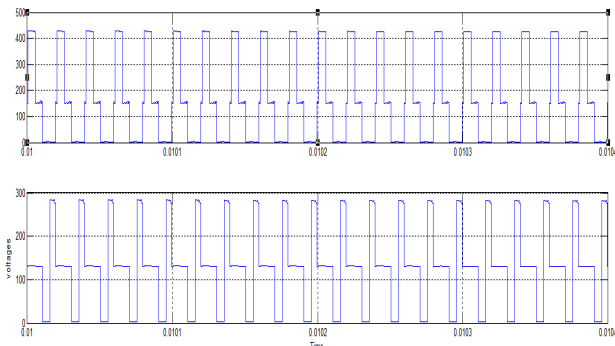

Fig.8 Simulated Top switch voltages V_{ds1} and V_{ds2} .

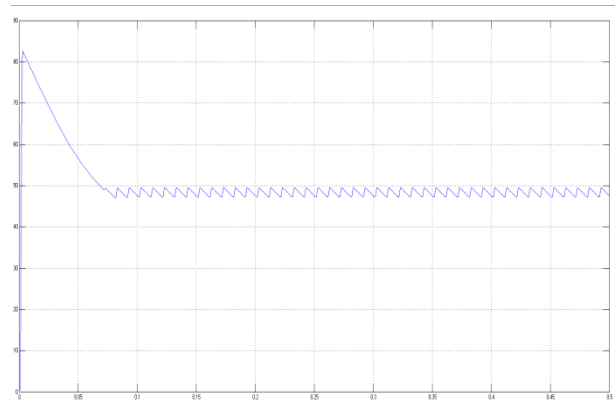

Fig.9 Simulated output wave form of the converter of the proposed converter.

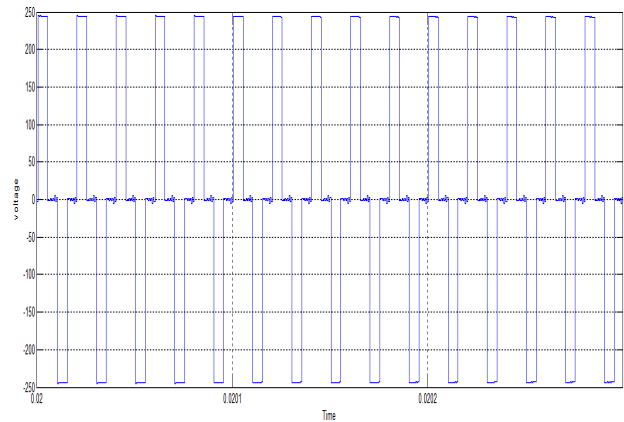

Fig.10. Simulated output wave form of the voltage at primary winding of the transformer of the proposed converter.

Case 2: Design of Closed -Loop Circuit of Proposed AC-DC Converter

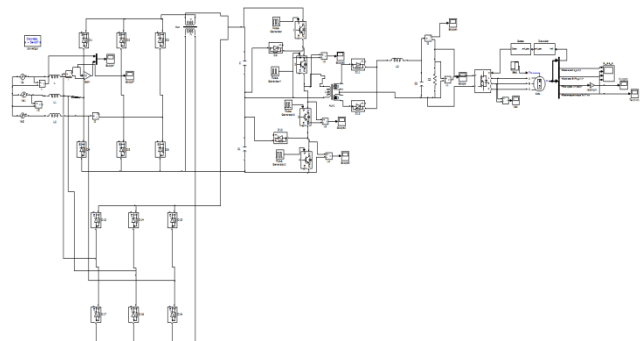

Fig.11. Matlab/Simulink Model of Proposed Converter Operated under BLDC Drive.

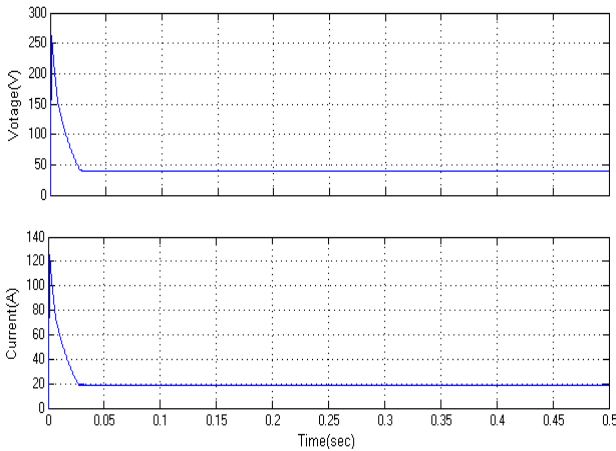

Fig.12. Output Voltage & Current of Proposed Converter Operated under Closed Loop Manner.

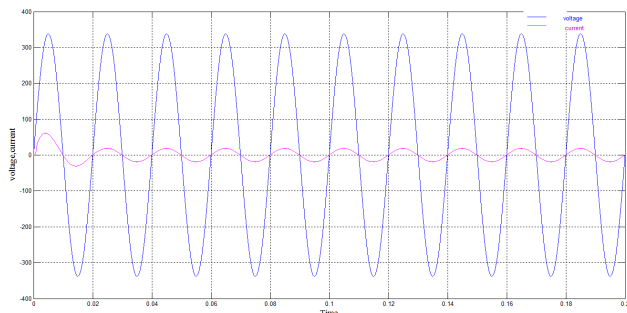

Fig.13. Simulated input wave form of the Voltage and current of the closed loop of proposed converter.

Fig.13. Source Side Voltage & Current – in Phase Condition, depicts the unity power factor at source side, with low THD response and maintain qualitated power at utility side, as per IEC standards

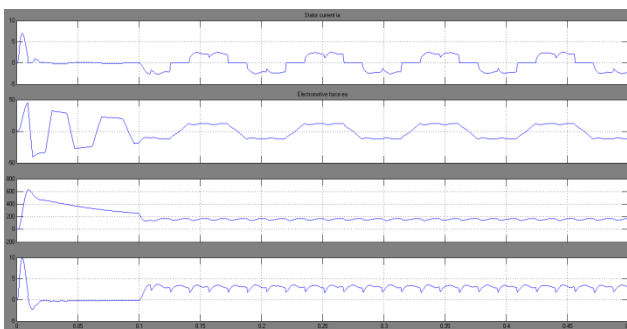

Fig 14. Performance characteristics of proposed concept of BLDC drive.

V. CONCLUSION

Numerous industrial applications have begun to require higher power apparatus in recent years. Power-electronic converters are becoming popular for various industrial applications. In this concept a new three level AC to DC converter for closed loop control logic for updating the performance of the dc drive and also a new three-phase three-level single-stage power-factor corrected ac-dc converter with interleaved input has been proposed in this paper. The converter operates with a single controller to regulate the output voltage and uses auxiliary windings

taken from its power transformer as magnetic switches to cancel the dc bus voltage so that the input section operates like a boost converter. The proposed converter can operate with input current harmonic content that meets the IEC1000-3-2 standard. The converter can operate with lower peak voltage stresses across the switches and the DC bus capacitors as it is a three-level converter. This converter provides variable output voltage with improved power factor. The all simulation results are verified through Matlab/simulink software.

REFERENCES

- [1] Mehdi Narimani, and Gerry Moschopoulos, "A New Interleaved Three-Phase Single-Stage PFC AC-DC Converter" *IEEE trans. Ind. Electron.*, VOL. 61, NO. 2, Feb 2014.
- [2] Limits for Harmonic Current Emission (Equipment Input Current>16 A per Phase), IEC1000-3-2 Int. Std., 1995.
- [3] Limits for Harmonic Current Emission (Equipment Input Current>16 A per Phase), IEC1000-3-4 Int. Std., 1998.
- [4] IEEE Recommended Practices and Requirements for Harmonic Control in Electric Power Systems, IEEE Std. 519-1992, Apr. 1993.
- [5] B. Tamyurek and D. A. Torrey, "A three-phase unity power factor single stage AC-DC converter based on an interleaved fly back topology," *IEEE Trans. Power Electron.*, vol. 26, no. 1, pp. 308–318, Jan. 2011.
- [6] J. M. Kwon, W. Y. Choi, and B. H. Kwon, "Single-stage quasi-resonant fly back converter for a cost-effective PDP sustain power module," *IEEE Trans. Ind. Electron.*, vol. 58, no. 6, pp. 2372–2377, Jun. 2011.
- [7] H. L. Cheng, Y. C. Hsieh, and C. S. Lin, "A novel single-stage high-power factor AC/DC converter featuring high circuit efficiency," *IEEE Trans. Ind. Electron.*, vol. 58, no. 2, pp. 524–532, Feb. 2011.
- [8] S. K. Ki and D. D.-C. Lu, "Implementation of an efficient transformer-less single-stage single-switch AC/DC converter," *IEEE Trans. Ind. Electron.*, vol. 57, no. 12, pp. 4095–4105, Dec. 2010.
- [9] H. Ma, Y. Ji, and Y. Xu, "Design and analysis of single-stage power factor correction converter with a feedback winding," *IEEE Trans. Power Electron.*, vol. 25, no. 6, pp. 1460–1470, Jun. 2010.
- [10] H. J. Chiu, Y. K. Lo, H. C. Lee, S. J. Cheng, Y. C. Yan, C. Y. Lin, T. H. Wang, and S. C. Mou, "A single-stage soft-switching fly back converter for power-factor-correction applications," *IEEE Trans. Ind. Electron.*, vol. 57, no. 6, pp. 2187–2190, Jun. 2010.
- [11] J. Zhang, D. D.-C. Lu, and T. Sun, "Fly back-based single-stage power factor-correction scheme with time-multiplexing control," *IEEE Trans. Ind. Electron.*, vol. 57, no. 3, pp. 1041–1049, Mar. 2010.
- [12] H. S. Ribeiro and B. V. Borges, "New optimized full-bridge single-stage AC/DC converters," *IEEE Trans. Ind. Electron.*, vol. 58, no. 6, pp. 2397–2409, Jun. 2011.