

# Power Management for DC Micro grid with Hybrid Storage System Fed Induction Motor Drive

U. SAMPATH KUMAR

M-tech Student Scholar

Department of Electrical & Electronics  
Engineering,

Sri Indu Institute of Engineering &  
Technology; Hyderabad, Telangana, India.

L.LAKSHMI

Assistant Professor

Department of Electrical & Electronics  
Engineering,

Sri Indu Institute of Engineering &  
Technology; Hyderabad, Telangana, India.

MR. SURESH H BALLALA

HOD Details

Department of Electrical & Electronics  
Engineering,

Sri Indu Institute of Engineering &  
Technology; Hyderabad, Telangana, India.

**Abstract**—Continuously increasing demand of Microgrid with high penetration of distributed energy generators, specially focused on renewable energy sources is modifying the traditional structure of the electric distribution grid. In addition, DC micro grids diverted the attention of researchers and power electronics industry in recent years to stimulate renewable energy technologies (RETs) and distributed energy resources (DERs) deployment and encouraging technological innovation to reduce green house gas (GHG) emission and achieve energy security and independence to meet the growing electricity demand. So for many studies have been done on successful integration of RETs and DERs, operation and control, protection and stability issues, simultaneously and satisfactorily implemented during feasible operation of microgrid. Studies show that DC transmittable power can increase the system efficiency up as compared to AC. But still DC bus voltage fluctuation, power quality and flow during the transition between grid connected mode to islanded mode or transient load insertion which intend to DC microgrid instability are the problems which need to be investigated and resolved for the effective use of DC microgrid generation. In this concept DC microgrid voltage, power flow, power quality and energy management different controls and techniques are reviewed. This concept can be extended as Induction Motor drive Power management for DC Microgrid Application.

**Keywords**— DC microgrid, bus voltage, energy storage system

## I. INTRODUCTION

Nowadays, the problem of energy crisis has been increasingly tense, while low carbon energy need to be developed. In this context, distributed renewable energy has been paid more attention and developed greatly, especially wind power and photovoltaic (PV) generation, due to their abundant availability and less impact on the environment. But theory and practice have proved that these distributed renewable energy have some inherent problems, such as its intermittency, which has some negative impact on the

security, reliability and power quality of utility grid [1]. On this basis, the concept of microgrid presented by Robert Lasseter and other scholars is considered to be a feasible scheme to solve the problem. The microgrid is a local energy network that includes renewable energy sources and storage systems. It can be connected to the mains grid or works isolated when there is a blackout at the main grid, and continues to supply their local loads in “islanded mode” [2-3]. A microgrid can be designed to support alternating current (AC) or direct current (DC). Compared with AC forms, DC microgrid can avoid the consideration of reactive power and frequency synchronization [4]. At the same time, some DC sources and DC loads, such as photovoltaic, super-capacitor, EV and LED, provide opportunities for DC microgrid. Also, DC microgrid will have the capability to increase the overall system efficiency compared to AC system. On the other hand, storage systems are usually installed to alleviate system power mismatch between generation and consumption in DC microgrid, and they can improve the stability, power quality, reliability of supply and overall performance of microgrid.

Storage systems can be characterized based on power density, energy density, ramp rate, life cycle and so on, but none of the storage systems fulfill all expected features. The typical energy storage in practical engineering is lead acid batteries, which possess high energy density but low power density, low charge/discharge rates and life span of less than 1000 full cycle. So batteries can't respond immediately under frequent load fluctuations. Compared to battery, super-capacitor has high power density but low energy density, high charge/discharge rates and life span of around 500,000 cycles. Therefore, super-capacitor can be used to match the quick load fluctuations [5-6].

The combination of the two types is crucial for diverse energy storage needs of both fast and slow fluctuating power and it has become a research hotspot, and the structure of two-types storage systems have been the subject of more research programs, such as the combination of batteries and super-capacitors. Authors in [7-8] demonstrated the hybrid energy storage systems lowers the battery cost and improves the overall system efficiency. The system integration of PV array, batteries, and super-capacitors has been studied in several literatures, but this system still has some shortcomings [9-11].

Firstly, when it is an islanding mode, electricity shortages occur at times. Secondly, photovoltaic redundant energy will be wasted when storage systems have been fully charged. From the above, we consider how the DC microgrid based on PV array with a hybrid storage system connected with utility grid works. We present a novel power management of DC microgrid to realize system stability, low voltage regulation and equal load sharing in each unit. It is confirmed that the steady state and transient state conversion of different operation mode through MATLAB/SIMULINK simulation platform. The paper is organized as follows. In section II, system configuration of this microgrid and its modeling are discussed. Section III describes the control strategy and operation modes of this microgrid. The simulation results of the proposed system are given in Section IV. Finally, the conclusions of the paper are summarized in section V.

## II. SYSTEM CONFIGURATION

A grid-connected DC microgrid investigated in this paper is shown in Fig.1. It consists of PV-panel, hybrid storage unit, utility grid, DC/DC converters, DC/AC converter and DC load. The PV panel is connected to the DC bus through a boost DC/DC converter which extracts the maximum power from PV panel using maximum power point tracking (MPPT) algorithm. The hybrid energy storage unit is composed of lead-acid batteries and super-capacitors. The batteries and the super-capacitors are connected with the DC bus through two bi-directional half-bridge DC/DC converters. The utility grid is connected to the DC bus through a three-phase bi-directional full-bridge AC/DC converter.

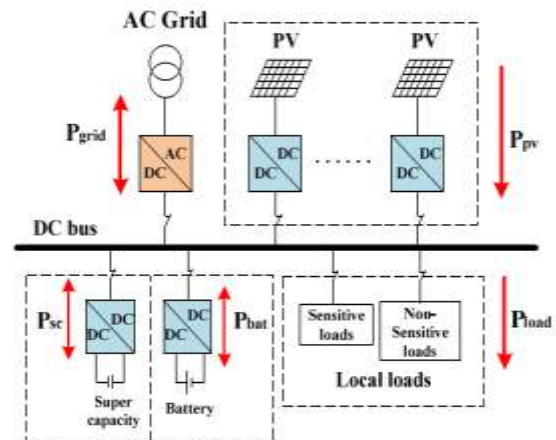

Fig.1. DC microgrid with hybrid storage system

**A. MPPT control of PV module:** The photovoltaic (PV) cells are connected in series to form a module that gives a standard dc voltage. Modules are connected into an array to produce sufficient current and voltage to meet a demand for a grid-connected application [12]. Normally, the PV modules are first connected in series into strings and then in parallel into an array. The PV model can be described by detailed equation. The power produced by a PV array is dependent on the irradiance and temperature. There is a maximum power point (MPP) which should be tracked in the power-voltage (P-V) curve. It can be accomplished through DC/DC converter linking the PV array to the DC bus as shown in fig.2. Typical MPPT control strategies include open-circuit voltage method, short-current circuit current method, perturb and observe method (P&Q) and incremental conductance method (INC). In general, P&Q method and INC method are the widely used approaches for MPPT control. However, those conventional MPPT algorithms have disadvantages such as instability, poor adaptability to external environment. Sometimes they may fail to track the MPP when the atmospheric conditions change rapidly. The step size is automatically tuned according to the inherent PV array characteristics. If the operating point is far from MPP, it increases the step size which enables a fast tracking ability. If the operating point is near to the MPP, the step size becomes very small that the oscillation is well reduced contributing to a higher efficiency. The flow chart of the variable step size INC MPPT algorithm is shown in fig.3 and the variable step size  $\Delta V$  is automatically tuned.

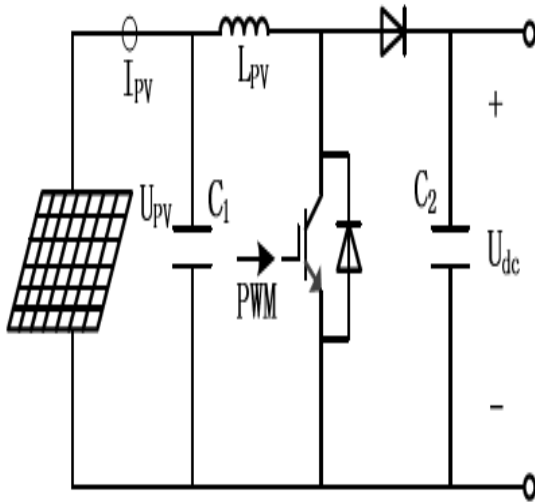

Fig.2 DC/DC converter of PV module with MPPT function

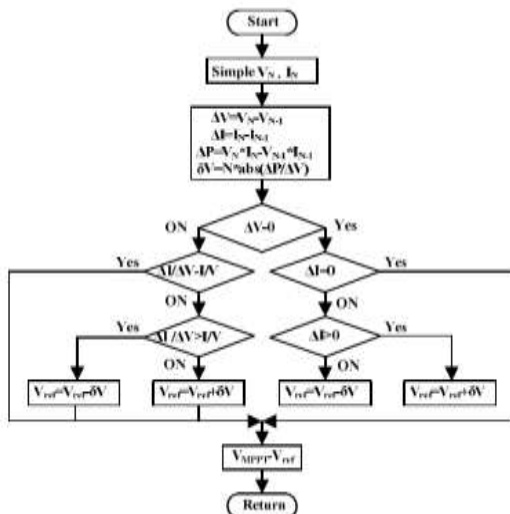

Fig.3 Flowchart of the variable step size INC MPPT algorithm

**B. Control of bi-directional DC/DC converter for hybrid energy-storage:** Battery has high energy density whereas it has relatively slow charging and discharging speed. On the other hand, super-capacitor has high power density and fast response. The super-capacitor as a short-term energy storage device is utilized to compensate for fast changes in the output power, while the battery as a long-term energy storage device is applied to meet the energy demand [14]. The battery is modeled using a simple controlled voltage source in series with a constant resistance. The SC is modeled as a regular capacitor in series with a constant resistance. The bi-directional buck/boost converter is used in the paper to link the SC or battery with the DC bus. The structure of the

two converters is a parallel connection. This converter works as a boost converter during storage unit discharge mode and a buck converter during charge mode. The control method is a conventional double loop, including an inner current loop and an outer voltage loop, which is shown in Fig.4.

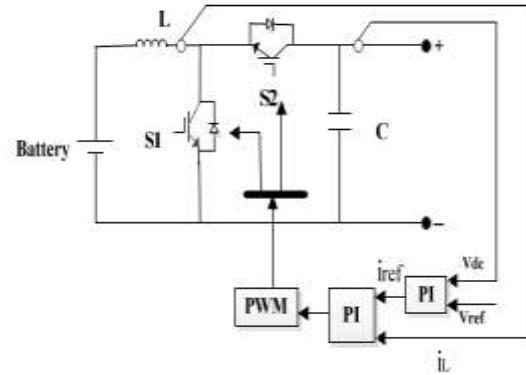

Fig.4 Control strategy of the bi-directional DC/DC converter

**C. The control of three phase bi-directional AC/DC converter:** The utility grid is connected to the DC bus through a three-phase bi-directional full-bridge AC/DC converter. The control strategy is a direct quadrature (DQ) current controller together with an outer voltage control loop as illustrated in fig.5. When utility grid works normally, the DC bus will be connected to utility grid through the bi-directional converter and the power will be transmitted mutually; otherwise it will be disconnected with utility grid to avoid faults.

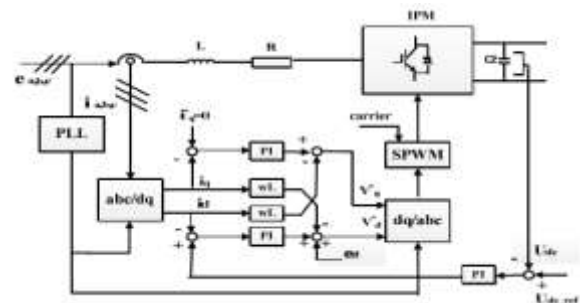

Fig.5 Control strategy of the bi-directional DC/AC converter

### III. CONTROL STRATEGY

A novel power management strategy of DC microgrid is proposed in this paper. The key point of power management scheme in DC microgrid is to keep the power balance among PV module, storage systems, utility grid and loads all the time, which is manifested by DC bus voltage [15-17]. The super-capacitor is the secondary power supply as auxiliary power of PV power and it works when there are

surges or energy bursts in the system. The utility grid is the next place of the power supply priorities when there is bulk energy mismatch over a longer time period. The structure can lower the loss of lifetime of the battery in the conditional microgrid. Finally, when the main grid faults, the accessorial batteries will charge or discharge to keep the DC bus voltage steady.

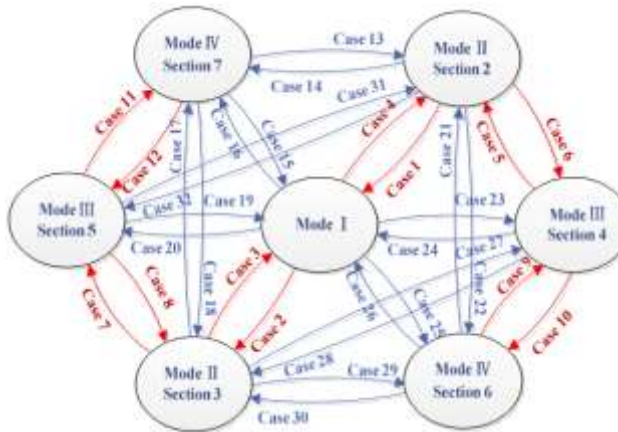

Fig.6 Mode transition mechanism

TABLE 1 SUMMARY OF EACH MODE AND ITS CHARACTERISTICS

Mode Name	Power Characteristic	Bus Voltage Range	Bus Regulation	Power Supply
Mode I (section 1)	$P_p = P_{out}$	$U_{low} < U_c < U_{high}$	PV Unit	PV
Mode II (section 2)	$P_p + P_c = P_{out}$	$U_{low} < U_c < U_{high}$	Supercapacitor Unit	PV, Supercapacitor
Mode II (section 3)	$P_p + P_c = P_{out}$	$U_{low} < U_c < U_{high}$	Supercapacitor Unit	PV, Supercapacitor
Mode III (section 4)	$P_p + P_u = P_{out}$	$U_{low} < U_c < U_{high}$	Utility Unit	PV, Utility grid
Mode III (section 5)	$P_p + P_u = P_{out}$	$U_{low} < U_c < U_{high}$	Utility Unit	PV, Utility grid
Mode IV (section 6)	$P_p + P_b = P_{out}$	$U_c < U_{high}$	Battery Unit	PV, Battery
Mode IV (section 7)	$P_p + P_b = P_{out}$	$U_{low} < U_c$	Battery Unit	PV, Battery

At the same time, the system also has several abnormal cases drawn by blue arrow lines, as shown in fig.7. These abnormal cases will happen when certain source or certain converter is in trouble. For example, the case 15 and case 16 between mode I and mode IV will happen in the situation that the utility grid or grid-connected converter breaks down and super-capacitor is full. Actually, it has twenty

abnormal cases in unexpected situations. In table I, we have summarized each mode and its characteristic. In general, the switching between different modes and the changes of control methods for converters can be achieved through bus voltage changes without communication links. These modes are analyzed in the following paragraphs:

**Mode I:**  $U_{low} < U_c < U_{high}$ . In this mode, the DC bus voltage is regulated only by the PV generation, which means the generated PV power just matches the demands. The bus voltage fluctuates at the reference value in a small range. At the same time, the other converters are in the standby state. The power flow is shown in fig.8

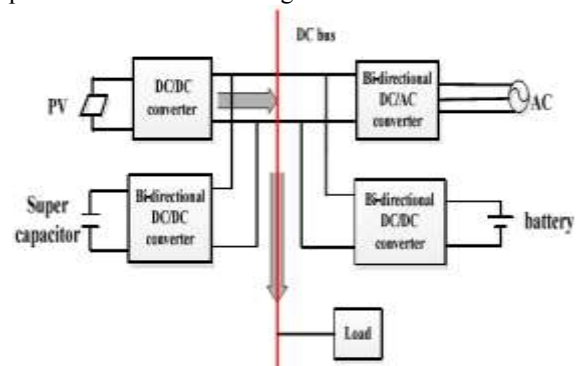

Fig.8 Power flow of mode I

#### IV INTRODUCTION OF INDUCTION MOTOR

An induction motor (IM) is a type of asynchronous AC motor where power is supplied to the rotating device by means of electromagnetic induction. Other commonly used name is squirrel cage motor due to the fact that the rotor bars with short circuit rings resemble a squirrel cage (hamster wheel). An electric motor convert's electrical power to mechanical power in its rotor.

There are several ways to supply power to the rotor. In a DC motor this power is supplied to the armature directly from a DC source, while in an induction motor this power is induced in the rotating device. An induction motor is sometimes called a rotating transformer because the stator (stationary part) is essentially the primary side of the transformer and the rotor (rotating part) is the secondary side. Induction motors are widely used, especially poly phase induction motors, which are frequently used in industrial drives.

The Induction motor is a three phase AC motor and is the most widely used machine. Its characteristic features are-

- Simple and rugged construction
- Low cost and minimum maintenance
- High reliability and sufficiently high efficiency



□ Needs no extra starting motor and need not be synchronized

□ An Induction motor has basically two parts – Stator and Rotor

The Stator is made up of a number of stampings with slots to carry three phase windings. It is wound for a definite number of poles. The windings are geometrically spaced 120 degrees apart. Two types of rotors are used in Induction motors - Squirrel-cage rotor and Wound rotor

### AC Induction Motor

The AC induction motor is a rotating electric machine designed to operate from a 3-phase source of alternating voltage. For variable speed drives, the source is normally an inverter that uses power switches to produce approximately sinusoidal voltages and currents of controllable magnitude and frequency. A cross-section of a two-pole induction motor is shown in Slots in the inner periphery of the stator accommodate 3-phase winding amebic. The turns in each winding are distributed so that a current in a stator winding produces an approximately sinusoid ally-distributed flux density around the periphery of the air gap. When three currents that are sinusoid ally varying in time, but displaced in phase by 120° from each other, flow through the three symmetrically-placed windings, a radically-directed air gap flux density is produced that is also sinusoid ally distributed around the gap and rotates at an angular velocity equal to the angular frequency, of the stator currents. The most common type of induction motor has a squirrel cage rotor in which aluminum conductors or bars are cast into slots in the outer periphery of the rotor. These conductors or bars are shorted together at both ends of the rotor by cast aluminum end rings, which also can be shaped to act as fans. In larger induction motors, Copper or copper-alloy bars are used to fabricate the rotor cage winding.

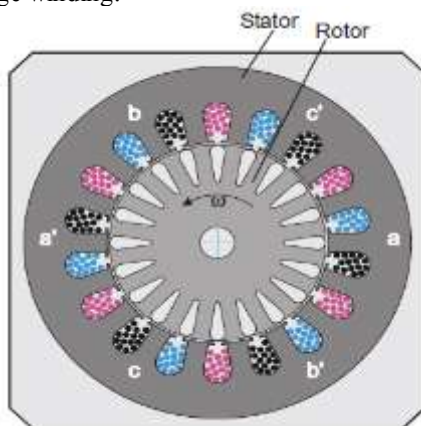

Fig 9 3-Phase AC Induction Motor

As the sinusoidally-distributed flux density wave produced by the stator magnetizing currents sweeps past the rotor conductors, it generates a voltage in them. The result is a sinusoidally-distributed set of currents in the short-circuited rotor bars. Because of the low resistance of these shorted bars, only a small relative angular velocity,  $r$ , between the angular velocity,  $s$ , of the flux wave and the mechanical angular velocity of the two-pole rotor is required to produce the necessary rotor current. The relative angular velocity,  $r$ , is called the slip velocity. The interaction of the sinusoidally-distributed air gap flux density and induced rotor currents produces a torque on the rotor. The typical induction motor speed-torque characteristic is shown in Figure 2.2.

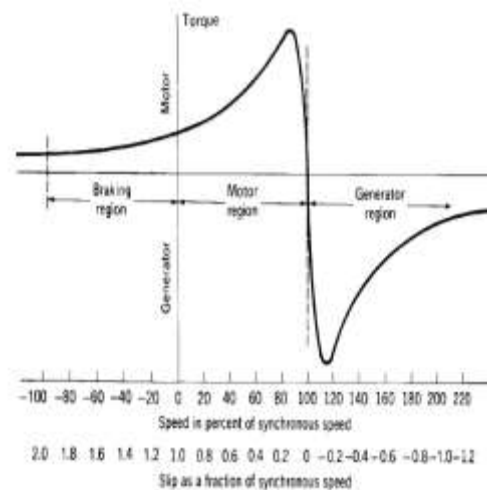

Fig 10 AC Induction Motor Speed-Torque Characteristic

Squirrel-cage AC induction motors are popular for their simple construction, low cost per horsepower, and low maintenance (they contain no brushes, as do DC motors). They are available in a wide range of power ratings. With field-oriented vector control methods, AC induction motors can fully replace standard DC motors, even in high-performance applications.

### V. SIMULATION RESULTS

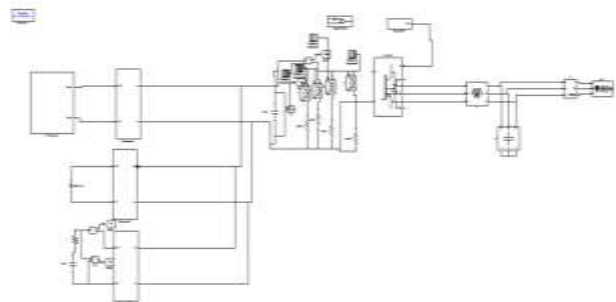

Fig 11 MATLAB/Simulink model of DC microgrid

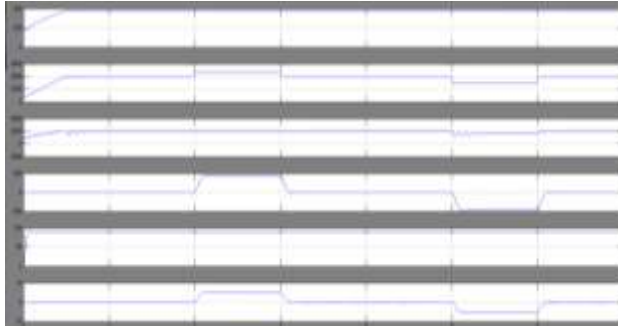

Fig 12 Transition process between Mode I and Mode II

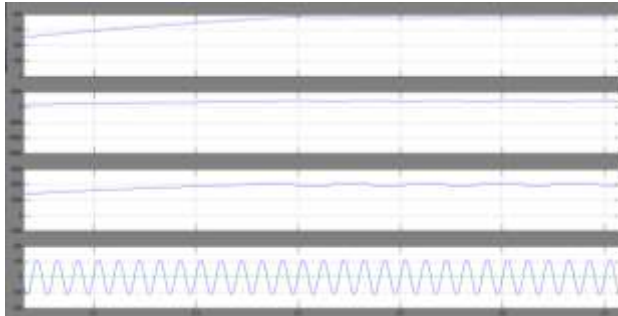

Fig 13 Transition process between Mode I and Mode III

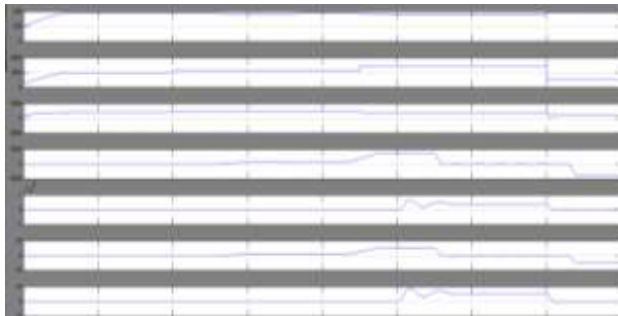

Fig 14 Transition process between Mode II and Mode IV

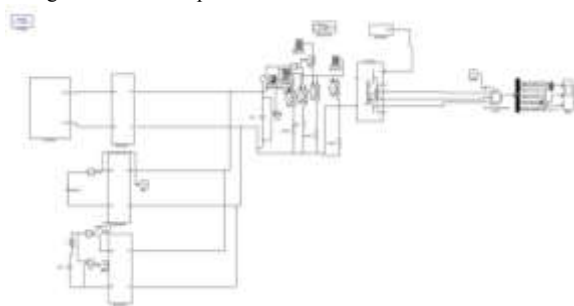

Fig 15 MATLAB/Simulink model of DC microgrid with Induction Motor

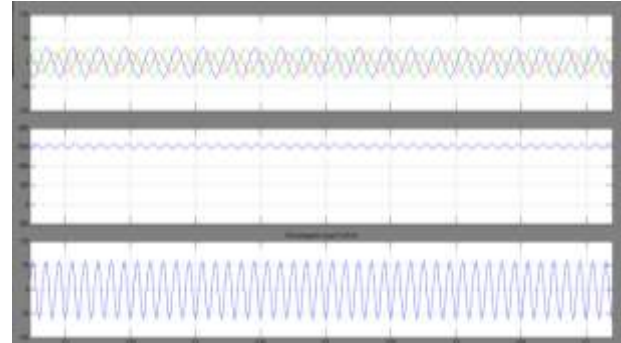

Fig 16 simulation wave form of DC microgrid with Induction Motor stator current, speed and electromagnetic torque

## VI. CONCLUSION

In the paper, a DC microgrid with hybrid storage system is investigated. A power management strategy for this DC microgrid is proposed, in which the bus voltage is employed as a carrier to represent different operation modes. The hybrid energy storage system in this microgrid that contains two complementary type storage elements---battery and super-capacitor, can enhance the reliability and flexibility of the system based on their special supply logical. Different from the previous studies, the ac grid has a new supply status in the system. The practical feasibility and the effectiveness of the proposed control strategies have been validated by the Induction motor drive application simulation of MATLAB model.

## VII. REFERENCE

- [1] Lasseter, R.H. "Microgrids," Power Engineering Society Winter Meeting, New York, Vol.1, Jan.2002, pp:305-308.
- [2] Estefanía Planas, Jon Andreu, José Ignacio Gárate, Iñigo Martínez de Alegría, Edorta Ibarra. "AC and DC technology in microgrids: A review," Renewable and Sustainable Energy Reviews, Vol 43, Mar. 2015, pp:726-749
- [3] Gianfranco Chicco, Pierluigi Mancarella. "Distributed multi-generation: A comprehensive view," Renewable and Sustainable Energy Reviews, Vol.13 , Apr.2009, pp:535-551
- [4] Nanfang Yang, Damien Paire, Fei Gao, Abdellatif Miraoui , Weiguo Liub. "Compensation of droop control using common load condition in DC microgrids to improve voltage regulation and load sharing," International Journal of Electrical Power & Energy Systems, Vol.64, Jan. 2015, pp:752-760,
- [5] R. Sathish kumar, K. Sathish Kumar, and M. K. Mishra, "Dynamic energy management of micro grids using battery super capacitor combined storage," in Proc. 2012 Annual IEEE India Conference (INDICON), Dec.2012, pp: 1078-1083.

- [6] Z. Guoju, T. Xisheng, Q. Zhiping, "Research on battery supercapacitor hybrid storage and its application in microgrid," in Proc. 2010 IEEE Power and Energy Engineering Conference, Mar.2010, pp:1-10 [7] G. M. Masters, Renewable and Efficient Electric Power Systems, Wiley-IEEE Press, 2004.
- [8] Sathishkumar R, Sathish Kumar Kollimalla, Mahesh K. Mishra. "Dynamic energy management of micro grids using battery super capacitor combined storage," 2012 Annual IEEE India Conference (INDICON), Dec.2012, PP:1078 – 1083.
- [9] Xiaolei Hu, K.J.Tseng and M.Srinivasan. "Optimization of Battery Energy Storage System with Super-Capacitor for Renewable Energy Applications," in IEEE 8th International Conference on Power Electronics and ECCE Asia (ICPE & ECCE), May .2011, pp:1552-1557
- [10] Zhixue Zheng, Xiaoyu Wang, Yongdong Li. "A Control Method for Grid-friendly Photovoltaic Systems with Hybrid Energy Storage Units," in International Conference on Electric Utility Deregulation and Restructuring and Power Technologies, Jul.2011, pp:1437-1440
- [11] Sathish Kumar Kollimalla, Mahesh Kumar Mishra, Lakshmi Narasamma N. "A New Control Strategy for Interfacing Battery Super-capacitor Storage Systems for PV System," 2014 IEEE Students' Conference on Electrical, Electronics and Computer Science, Mar. 2014, pp:1-6
- [12] Hicham Fakhm, Di Lu, and Bruno Francois. "Power Control Design of a Battery Charger in aHybrid Active PV Generator for Load-Following Applications," IEEE Trans. Ind. Electron, vol.46, no. 1,Jan.2011, pp:85-94
- [13] Tong Yap, Yingying Tang, Raja Ayyanar. "High Resolution Output Power Estimation of Large-Scale Distributed PV Systems," in Energy Conversion Congress and Exposition (ECCE), Spept.2014, pp:4620-4627.
- [14] Jiyong Li and Honghua Wang. "A Novel Stand-alone PV Generation System Based on Variable Step Size INC MPPT and SVPWM Control," IEEE 6th International Power Electronics and Motion Control Conference, May.2009, PP:2155-2160
- [15] Xiao Jianfang, Wang Peng, Leonardy Setyawan. "Hierarchical Control of Hybrid Energy Storage System in DC Microgrids," IEEE Trans. Ind. Electron., Vol 99, Feb.2015, pp:1-10
- [16] Liu Jiaying, Han Xiaoqing, Wang Lei, Zhang Peng, Wang Jing "Operation and Control Strategy of DC Microgrid," Power System Technology in Chinese, Vol.38, no.9, 2014, pp:2356-2362
- [17] Dan Shen, Afshin Izadian. "Sliding Mode Control of A DC Distributed Solar Microgrid," Power and Energy Conference at Illinois (PECI), Feb.2015, PP:1-6.
- [18] Liu Baoquan, Zhuo Fang, Bao Xianwen. "Control Method of the Transient Compensation Process of a Hybrid Energy Storage System Based on Battery and Ultra-Capacitor in Microgrid," 2012 IEEE International Symposium on Industrial Electronics (ISIE),. May.2012, pp: 1325-1329.
- [19] Huiying Zheng, Shuhui Li, Chuanzhi Zang, Weijian Zheng. "Coordinated Control for Grid Integration of PV Array, Battery Storage, and Super-capacitor," 2013 IEEE

Power and Energy Society General Meeting (PES) , July.2013, pp:1-6.

Authors profile:



U.Sampath Kumar M.Tech student Scholar presently pursuing M.Tech in prestigious Sri Indu Institute of Engineering & Technology, Hyderabad, India.



L.Lakshmi is presently working as Assistant professor in prestigious Sri Indu Institute of Engineering & Technology, Hyderabad, India



Mr. Suresh Ballala is presently working as Associate professor & HOD of Electrical & Electronics Engineering in prestigious Sri Indu Institute of Engineering & Technology, Hyderabad, India. He obtained M.Tech in Digital Electronics and Communication Systems from JNTUH. B.Tech from Basaveshwara Engg College, Bagalkot, Karnataka University. He won Third prize in a seminar contest organized by Asia Pacific Telecommunications Young Professionals and Students Forum, Ministry of Information Technology in association with BSNL at IETE-. From last 17 years he is guiding the students in Enhancement of Embedded Systems.