

Harmonics and Torque Ripple Reduction in BLDC Drive using Multilevel Inverter

T.RAJENDRAPRASAD

M-tech Student Scholar

Department of EEE,

Sarada Institute of Science Technology & Management.

Srikakulam (Dt); A.P, India

S.DEEP SANTOSH

Assistant Professor

Department of EEE

Sarada Institute of Science Technology & Management.

Srikakulam (Dt); A.P, India

Abstract: - Considering the drive advantages of BLDC drive compared to other drive applications BLDC with phase switching inverter performance is improved with multilevel inverter (MLI) topologies employing current and speed control techniques which decrease the torque ripples and harmonic distortion in general three phase three level inverter which commutates the BLDCM and address the problems of harmonics and torque ripples for that by using a multilevel inverter topology of five level inverter with current and speed controller at lower switching levels which can improve the BLDC drive performance. This paper proposes a series connected five level inverter with phase shift modulation with current and speed control techniques to reduce the harmonic distortion and torque ripples. The simulation results are discussed with a comparative study in different operating strategies of BLDC drive. Finally seven level Cascaded multilevel inverter with PWM fed Brushless dc motor drive is implemented in Matlab / Simulink and simulation results are presented for verification and validation of the proposed work.

Keywords: - Cascaded H-Bridge (CHB) Multilevel inverter (MLI), Total harmonic distortion (THD), Pulse Width Modulation (PWM), Switching frequency.

I. INTRODUCTION

Brushless DC Motor with trapezoidal BEMF has numerous favorable circumstances. It has high proficiency and high power thickness, unwavering quality in light of the fact that the nonappearance of field winding and brushes. So it has low support, Simple casing and grinding, high ability. Despite the fact that in a reasonable case BLDC drive have torque throbs because of Back EMF abandonment from the perfect. Torque swell produces clamor and issue of pace control. Due to Power electronic compensation, diode freewheeling of latent stages and High recurrence exchanging of force electronic gadgets, another issue is inverter yield or info of the BLDC Motor have numerous music that will create Electromagnetic Interference. Brushless direct current (BLDC) engines have qualities of high dependability, basic casing, and little grinding. By contrasting and PMSM, BLDC engine has the benefits of rapid conforming execution and force thickness [1]. The torque swell decrease and the control execution change of BLDC primarily centered around compensation torque swell, the torque swell created by diode freewheeling of idle stage, and the torque swell brought on by the non-perfect back electromotive power (EMF). For the

recompense torque swell, Calson et al. suggested that relative torque is identified with current and differs with rate. In, a solitary dc current sensor and a versatile stage change point regulation plan ought to be utilized to smother the replacement torque swell, however the diode freewheeling of dormant stage was not considered. Chuang et al. have dissected the mastery of distinctive heartbeat width regulation (PWM) designs on the recompense torque swells as per the BLDC engines with perfect trapezoidal back EMF [6], the corresponding vital (PI) controller is a surely understood framework in control building. It is fundamentally a slack compensator portrayed by the exchange capacity [2]. BLDC engine position can be detected from Back EMF (BEMF). It has been worked fitting exchanging of inverters. Yield rate of BLDC engine can be detected and contrasted with the reference velocity utilizing comparator. So mistake created sign is sent as information for PI controller. PI controller endeavors to right that slip between a deliberate procedure variable and wanted set point by computing and after that yielding restorative activity that can modify the procedure appropriately. The PI controller figuring includes two separate modes, the corresponding mode, and indispensable mode. The relative (KP) mode focus the response to the present mistake, essential (Ki) mode decides the response based late blunder. The weighted total of the two modes (KP and Ki) yield as restorative activity to the control component. PI (Proportional fundamental) controller is broadly utilized as a part of industry because of its straightforwardness in outline and basic structure [3].

Nowadays researchers are trying to reduce the torque ripple and harmonic component in the BLDC motor. An active topology to reduce the torque ripple is synchronous motor presented in [4]. This paper discusses the hysteresis voltage control method. The torque ripple is minimized using PWM switching is presented in paper [5], this scheme has been implemented using a PIC microcontroller to generate modified pulse width modulation (PWM) signals for driving power inverter bridge. However, a high number of levels increases the control complexity and introduces voltage imbalance problems. Three different topologies have been proposed for multilevel inverters: diode-clamped or neutral point clamped, flying capacitors clamped and cascaded multi

cell with separate dc sources. In addition, several modulation and control strategies have been developed or adopted for multilevel inverters including the following: multilevel sinusoidal pulse width modulation (SPWM).

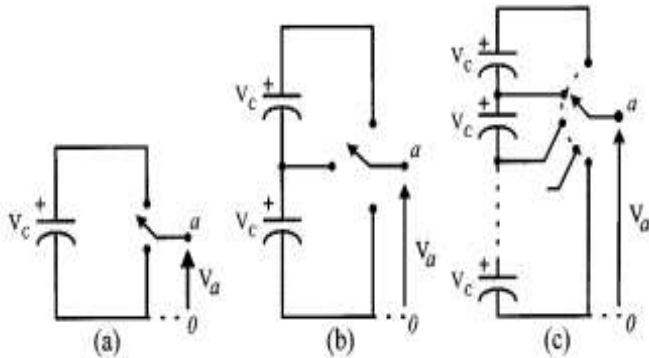

Figure. 1. One phase leg of an inverter with (a) two levels, (b) three levels, and (c) N levels

A multilevel converter has several advantages over a conventional two-level converter that uses high switching frequency pulse width modulation (PWM) [6],[7],[8]. The attractive features of a multilevel converter are, (a) Staircase waveform quality: Multilevel converters not only can generate the output voltages with very low distortion, but also can reduce the dv/dt stresses; therefore electromagnetic compatibility (EMC) problems can be reduced. (b) Common-mode (CM) voltage: Multilevel converters produce smaller CM voltage; therefore, the stress in the bearings of a motor connected to a multilevel motor drive can be reduced. (c) Input current: Multilevel converters can draw input current with low distortion. (d) Switching frequency: Multilevel converters can operate at both fundamental switching frequency and high switching frequency PWM. It should be noted that lower switching frequency usually means lower switching loss and higher efficiency. There are different approaches for the selection of switching techniques for the multilevel inverters [9].

II. FUNCTIONAL UNITS

The BLDC Motor requires a power electronic drive circuit and a commutation system for its operation. The Fig.1 describes the functional units present in the drive circuit and the associated commutation controller for the BLDC Motor. A 4 pole BLDC motor is driven by the inverter for 120 degree conduction. The rotor position can be sensed by a hall-effect sensor, providing three square wave signals with phase shift of 120°. These signals are decoded by a combinational logic to provide the firing signals for 120° conduction on each of the three phases. The operation of the system is as follows: as the motor is of the brushless dc type, the waveforms of the armature currents are quasi square. These currents are sensed through current sensors, and

converted to voltage signals. These signals are then rectified, and a dc component, with the value of the ceiling of the currents, I_{max} , is obtained as shown in Fig.2 This dc signal is compared with a desired reference I_{ref} , and from this comparison, an error signal I_{err} is obtained. This error is then passed through a PI control to generate the PWM as shown in Fig.3 for all the switches of the multi-level inverter which are sequentially activated by the shaft position sensor.

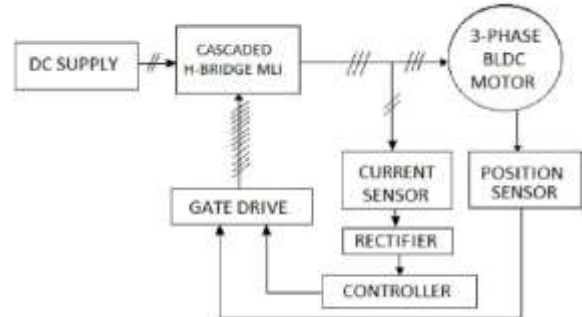

Fig.2 Current Controller of BLDC Motor with MLI

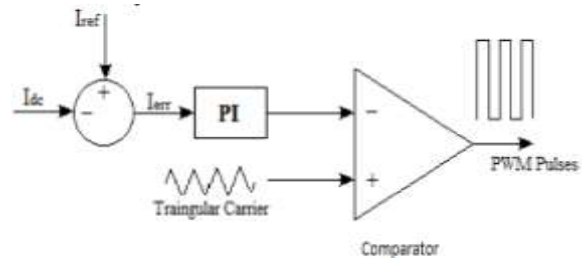

Fig. 3 Current Controller Block

III. CASCADED H BRIDGE CONVERTER

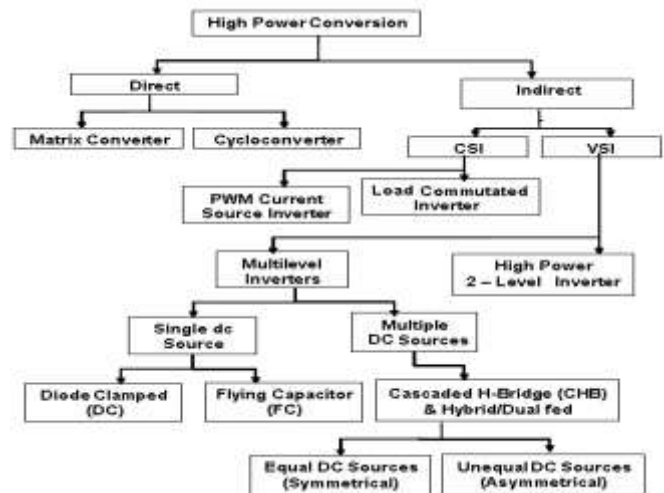

Fig.4 classifications of power converters

The N-level cascaded H-bridge, multilevel inverter comprises $\frac{1}{2}(N-1)$ series connected single phase H-bridges per phase, for which each H-bridge has its own isolated dc source. Three output voltages are possible, $\pm V_s$, and zero,

giving a total number of states of $3^{\frac{1}{2}(N-1)}$, where N is odd. Figure 5 shows one phase of a n-level cascaded H-bridge inverter.

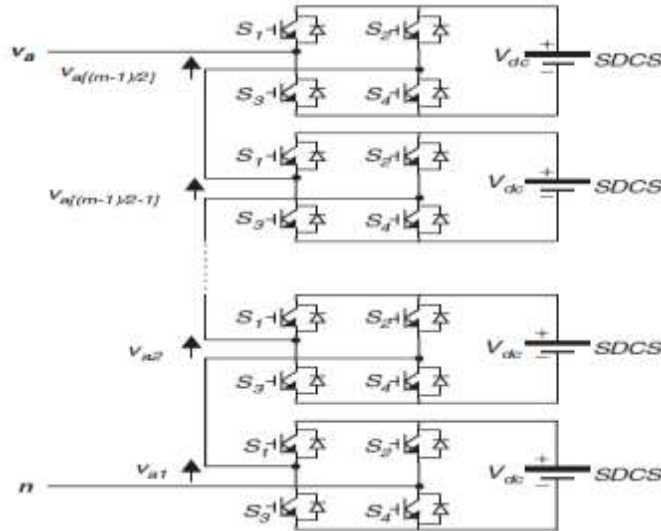

Figure 5. Single-phase structure of a multilevel cascaded H-bridge Inverter.

The cascaded H-bridge multilevel inverter is based on multiple two level inverter outputs (each H-bridge), with the output of each phase shifted. Despite four diodes and switches, it achieves the greatest number of output voltage levels for the fewest switches.

Its main limitation lies in its need for isolated power sources for each level and for each phase, although for VA compensation, capacitors replace the dc supplies, and the necessary capacitor energy is only to replace losses due to inverter losses. Its modular structure of identical H-bridges is a positive feature.

The number of levels in the line-to-line voltage waveform will be $k = 2N - 1$.

while the number of levels in the line to load neutral of a star (wye) load will be $p = 2k - 1$.

The number of capacitors or isolated supplies required per phase is $N_{cap} = \frac{1}{2}(N - 1)$.

The number of possible switch states is $n_{states} = N^{phases}$.

The number of switches in each leg is $S_n = 2(N - 1)$.

Advantages:

The number of possible output voltage levels is more than twice the number of dc sources ($m = 2s + 1$).

The series of H-bridges makes for modularized layout and packaging. This will enable the manufacturing process to be done more quickly and cheaply.

Disadvantages:

Separate dc sources are required for each of the H-bridges. This will limit its application to products that already have multiple SDCSs readily available.

A. Full H-Bridge- Three level inverter

Fig.6 shows the Full H-Bridge Configuration. By using single H-Bridge we can get 2 and 3 voltage levels. The number output voltage levels of cascaded Full H-Bridge inverter are given by $2n+1$ and voltage step of each level is given by V_{dc}/n . Where n is number of H-bridges inverter connected in cascaded. The switching table is given in Table I and II.

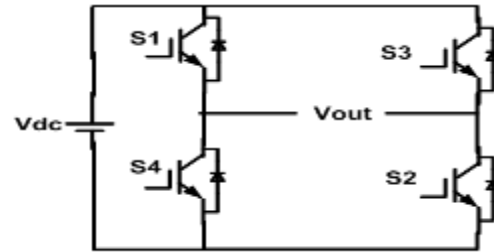

Figure 6. Full H-Bridge inverter
Table I Switching table for Full H-Bridge inverter

Switches Turn ON	Voltage Level
S1, S2	$V_{dc}/2$
S3, S4	$-V_{dc}/2$

Table II shows the Switching table for Full H-Bridge for three level inverter

TABLE II Switching table for Full H Bridge Three Level inverter

Switches Turn ON	Voltage Level
S1, S2	$V_{dc}/2$
S3, S4	$-V_{dc}/2$
S2, S4	0

B. Five level CHB Inverter

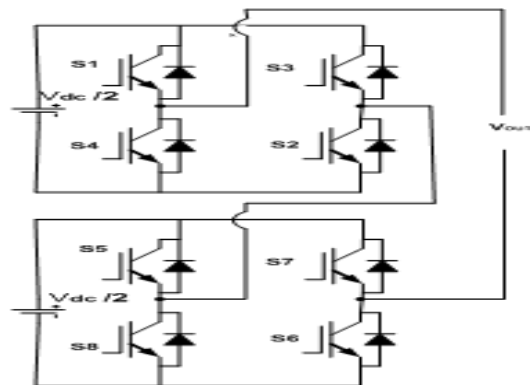

Figure.7. Five level CHB inverter

Figure 7 Shows the five level multilevel inverter and Table III shows the switching states of the 5 level inverter. Here even though we have eight switches at any switching state only two switches are on/off at a voltage level of $V_{dc}/2$, so switching losses are reduced. In three level inverter dv/dt is V_{dc} , but in five level inverter dv/dt is $V_{dc}/2$. As dv/dt reduces the stress on switches reduces and EMI reduces.

Table III Switching table for Full H-Bridge of five level inverter

Switches Turn ON	Voltage Level
S1,S2,S6,S8	$V_{dc}/2$
S1,S2,S5,S6	V_{dc}
S2, S4,S6,S8	0
S3,S4,S6,S8	$-V_{dc}/2$
S3,S4,S7,S8	$-V_{dc}$

C. Phase Shifted Pulse Width Modulation Scheme (PSPWM)

Phase shifted PWM (PS-PWM) is used with cascaded H-bridge (CHB) and flying capacitor (FC) inverters, since each cell is modulated independently using sinusoidal unipolar PWM and bipolar PWM, respectively, providing an even power distribution among the cells. A carrier phase shift of $180^\circ/m$ for the CHB and of $360^\circ/m$ for the FC is introduced across the cells to generate the stepped multilevel output waveform with lower distortion (where m is the number of cells). The difference between the phase shifts and the type of PWM (unipolar or bipolar) is because one CHB cell generates 3-level outputs, while one FC cell generates two level outputs and also used for many levels as shown in Fig.8.

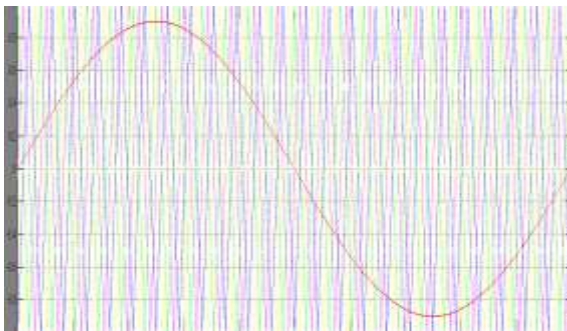

Fig.8. PSPWM Scheme.

IV.SIMULATION RESULTS

The simulation is carried out in Matlab/Simulink software and results are presented in different cases

Case1: Proposed five level inverter without PWM

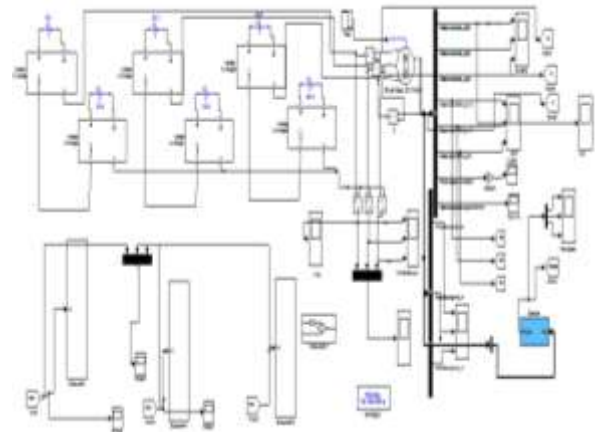

Fig.9. Matlab/Simulink Model of Five Level Inverter.

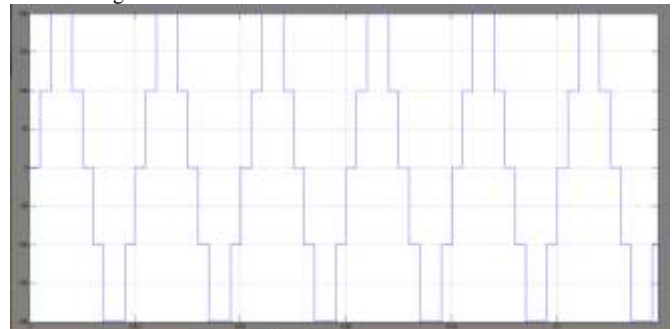

Fig. 10 phase to phase voltage of BLDC motor.



Fig.11 output of Hall Effect sensors.

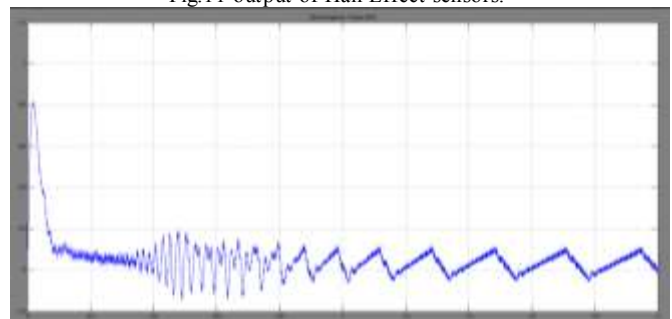

Fig.12 Torque waveform of BLDC Motor.

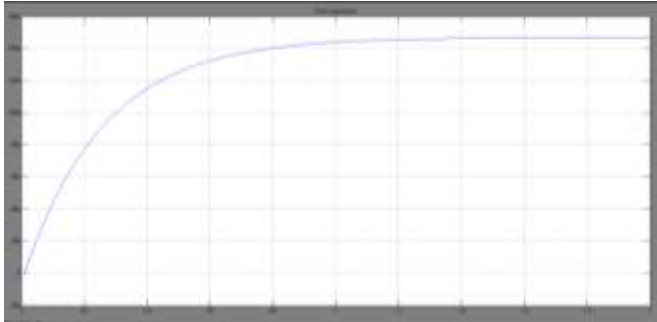

Fig.13 speed of BLDC Motor.

Case-2 proposed seven level inverter with PWM

The obtained value is compared with the triangular wave to generate controlled PWM signals

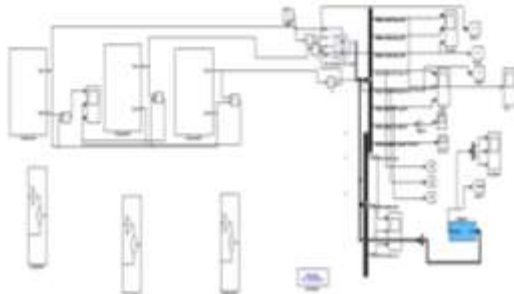

Fig.14. Matlab/Simulink Model of seven Level Inverter.

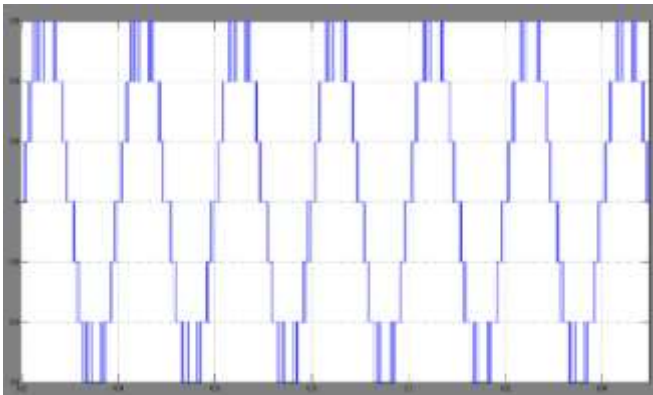

Fig.15. phase to phase voltage of BLDC motor.

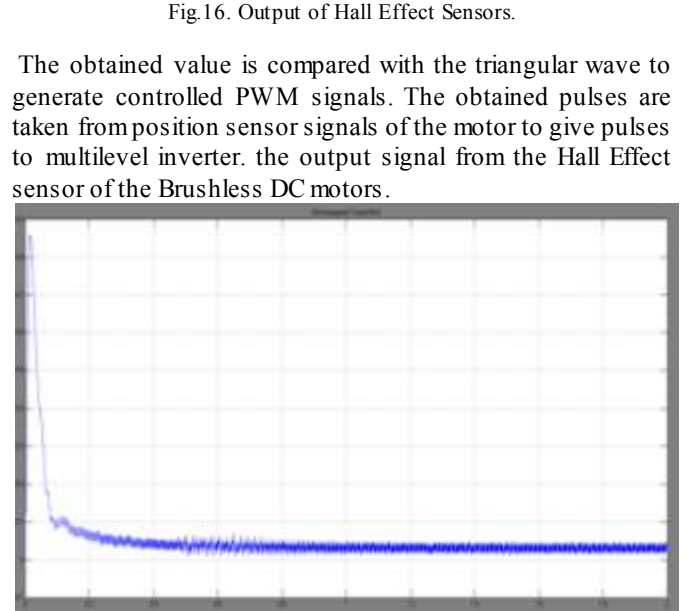

Fig.16. Output of Hall Effect Sensors.

The obtained value is compared with the triangular wave to generate controlled PWM signals. The obtained pulses are taken from position sensor signals of the motor to give pulses to multilevel inverter. the output signal from the Hall Effect sensor of the Brushless DC motors.

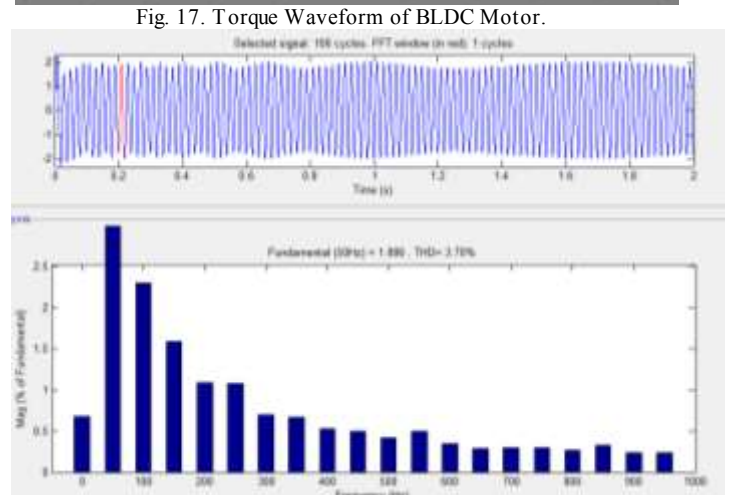

Fig. 18. FFT analysis of phase current A is 3.70%

The Fig.18 which shows the FFT analysis of the Phase A current of the Brushless DC motor. it is found that THD is 3.70%.

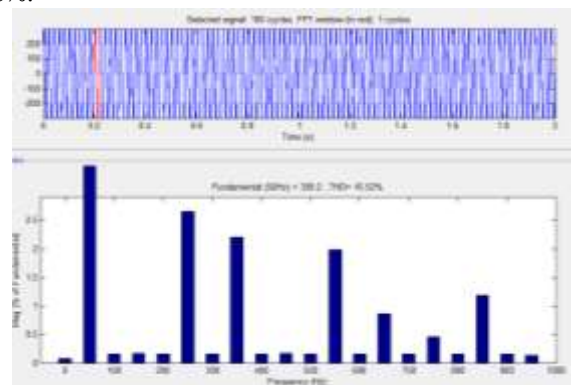

Fig. 19 FFT analysis of phase Voltage

The Total Harmonic Distortion (THD) which tells the amount of harmonics present in the current or voltage. In above figure shows the FFT analysis of the Phase-Phase voltage of the Brushless DC motor. The amount THD also calculated for this waveform. Is 16.52%

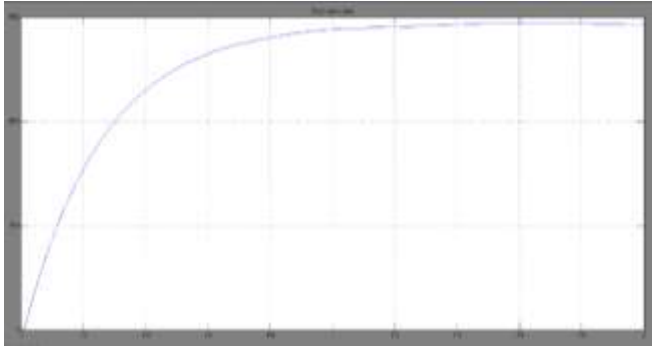

Fig.20.Speed of BLDC Motor

Fig.20 shows the speed waveform of Brushless DC motor. The harmonics and the torque ripple can be reduced by smoothening the current waveform.

V. CONCLUSION

Torque pulsations in BLDC motors brought about by the deviation from ideal conditions are either related to the design factors of the motor or to the power inverter supply, thereby resulting in non-ideal current waveforms. Undesirable torque pulsation in the BLDC motor drive causes speed oscillations and excitation of resonances in mechanical portions of the drive, leads the audible noise and visible vibration patterns in high precision machines. In this paper, a five level inverter with PI controller is presented for BLDC. This paper has proposed harmonics and torque ripples have been reduced using multilevel inverter with the current controlled technique. The harmonics content of the voltage and Current for a BLDC motor is analyzed and the amount of torque ripple and the THD also calculated. The main advantage of this method is it uses one current controller for the three phases. Finally a generalized expression for highest order harmonic based on switching frequency and number of levels is derived. Matlab/Simulink models are developed.

REFERENCES

- [1] T. Meynard, M. Fadel, and N. Aouda, "Modeling of multilevel converters," *IEEE Trans. Ind. Electron.*, vol. 44, pp. 356–364, June 1997.
- [2] F. Forest, J. Gonzalez, and F. Costa, "Use of soft-switching principles in PWM voltage converters design," in *Proc. Eur. Power Electron. Conf.*, 1993.
- [3] J. G. Cho, J.W. Baek, D.W. Yoo, and C. Y. Won, "Three level auxiliary resonant commutated pole converter for high power applications," in *Proc. IEEE PESC Conf.*, 1996, pp. 1019–1026
- [4] Y.S. Lai and F.S. Shyu. "Topology for hybrid multi level inverter", *IEE Proc-Electr. Power Appl.* Vol 149, No 6 nov 2002
- [5] M.D. Manjrekar, P.K. Steimer, and T.A. Lipo. "Hybrid multilevel power conversion system: A competitive solution for high power applications". *IEEE Transactions on Industry Applications*, 36(3):834–841, May/June 2000.

[6] K.A. Corzine, S.D. Sudhoff, and C.A. Whitcomb. "Performance characteristics of cascaded two-level converter". *IEEE Transactions on Energy Conversion*, 14(3), September 1999.

[7] A.k. Ali Othman "Elimination of harmonics in multi level inverters with non equal DC" [8] D. Soto, T. C. Green, "A comparison of high-power converter topologies for the Implementation of FACTS Controller," *IEEE Transaction of Industrial Electronics*, 49, N 5, p 1072-1080, 2002

[8] T. A. Lipo, D. G. Holmes, *Pulse width modulation for power converters: principles and practice*. NJ: John Wiley, 2003, pp. 96-411.

[9] Choi N.S., Cho J.G., Cho G.H. A General Circuit Topology of multilevel Inverter, in *IEEE Trans. On Power Electronics*, Vol.6, 1991, pp 96-103.