

# Study of Hybrid Power Conditioner for Suppressing Harmonics and Neutral Line Current in Three Phase Four Wire Distribution Power System

<sup>1</sup>K. BRAHMANI, <sup>2</sup>K. GANGADHAR, , <sup>3</sup>V.K. CHAKRAVARTHI NAIK

<sup>1</sup>M Tech Student, Department of EEE, SKU College of Engineering, Anantapur, India.

<sup>2</sup> Assistant professor Department of EEE, SKU College of Engineering, Anantapur, India,

<sup>3</sup> Assistant professor Department of EEE, SKU College of Engineering, Anantapur, India

**Abstract:** In this paper, a new hybrid power conditioner is proposed for suppressing harmonic currents and neutral-line current in three-phase four-wire distribution power systems. The proposed hybrid power conditioner is composed of a neutral-line current attenuator and a hybrid power filter. The hybrid power filter, configured by a three-phase power converter and a three-phase tuned power filter, is utilized to filter the nonzero-sequence harmonic currents in the three-phase four-wire distribution power system. The three-phase power converter is connected to the inductors of the three-phase tuned power filter in parallel, and its power rating can thus be reduced effectively. The tuned frequency of the three-phase tuned power filter is set at the fifth harmonic frequency. The neutral-line current suppressor is connected between the power capacitors of the three-phase tuned power filter and the neutral line to suppress the neutral-line current in the three-phase four-wire distribution power system. With the major fundamental voltage of the utility dropping across the power capacitors of the three-phase tuned power filter, the power rating of the neutral-line current suppressor can thus be reduced. Hence, the proposed hybrid power conditioner can effectively reduce the power rating of passive and active elements. A hardware prototype is developed to verify the performance of the proposed hybrid power conditioner. Experimental results show that the proposed hybrid power conditioner achieves expected performance.

**Keywords:** Dynamic-Implications of Technology, Technology Social Factors, Privacy.

## I. INTRODUCTION

Three-Phase four-wire distribution power systems been widely applied in office buildings and manufacturing- office buildings to supply single-phase or three-phase loads. The third harmonic is very serious in single-phase nonlinear loads. The third-order harmonic current of each phase is synchronous and regarded as the zero-sequence current. Therefore, the zero-sequence currents of each phase are summed up and flow into the neutral line of three-phase four-wire distribution power systems. Furthermore, single-phase loads may result in serious load unbalance, and the unbalanced load current also flows into the neutral line of the three-phase four-wire

distribution power systems. In many applications, the neutral-line current will exceed the phase currents. Excessive neutral-line current may cause accidents due to overload of the neutral line. Moreover, it will lead to fluctuation in ground voltage of the load, which may influence the operation of precision equipment. Hence, the major problems of three-phase four-wire distribution power systems are harmonic currents and neutral-line current. The zig-zag transformer, connected to the load in parallel, has been employed to attenuate the neutral-line current. However, the attenuation of neutral-line current is dependent on the ratio between the impedance of the utility system and the zig-zag transformer. Furthermore, the zig-zag transformer also has a low impedance path for zero-sequence voltage of the unbalanced utility, which will further cause a significant neutral line current. A single-phase power converter can be combined with the zig-zag transformer to advance the performance of the neutral-line current suppression.

The single-phase power converter is inserted at the neutral line between the load and the utility, thus causing fluctuation in the ground voltage of the load. A neutral-current suppression scheme, configured by a -Y transformer and a single-phase power converter connected in series, is connected to the load in parallel to suppress the neutral-line current. The neutral line of the load is directly connected to that of the utility, and the fluctuation in ground voltage of the load can thus be avoided. A series of active power filters connected to the neutral line between the utility and the load can suppress the neutral-line current, thus eliminating the need of the transformer for a zero current path. However, there is fluctuation in ground voltage of the load because the neutral lines of the load and utility are separated. Conventionally, passive power filters have been employed to solve the problems of harmonic currents and neutral-line current in three-phase four-wire distribution power systems. Although passive power filters have the advantage of low hardware cost, their performance is often significantly affected by the system impedance. Furthermore, salient problems, including large volume, parallel resonance, and series resonance may further offset the benefits of this method [9], [10]. With advances in power semiconductor technology, power-electronic- based active power equipment is gradually replacing or sharing the role of passive power equipment.

Active power filters have been proposed for suppressing the harmonic currents in single-phase and three-phase three-wire distribution power systems [11]–[13]. The three-phase four-wire active power filter can further suppress the neutral-line current in three-phase four-wire distribution power systems [13], [14]. Although active power filters can solve the majority of problems of three-phase four-wire distribution power systems, the capacity of the power converter must be larger than the product of the utility voltage and the current including the fundamental reactive current and the harmonic current of the load. Therefore, the capacity and manufacturing cost of this type of power converter is very high, thus limiting wide application of active power filters. Moreover, the switching power loss of the power converter due to high voltage and high current switching is significant. Hybrid power conditioners have been developed to solve the problems of passive and active power conditioners. A hybrid power filter consists of a passive power filter and a power converter [15]–[23]. In operation, the passive power filter can reduce the capacity of the power converter while the power converter is employed to improve the filter characteristics of the passive power filter. Hybrid power filters can be divided into series-linked type [15]–[17] and shunt type [18]–[24]. In hybrid power filters of the series-linked type, the power converter is connected between the utility and the load through a linked transformer, and the passive power filter is parallel to the load [15]–[17].

The voltage drop on the power converter is low in order to reduce the dc bus voltage. However, the current of the power converter, including the fundamental current of the load and the fundamental reactive current of the passive power filter, is still large. In hybrid power filters of the shunt type, the power converter is connected to the passive power filter in series and then connected to the load in parallel [18]–[21]. The major part of the utility voltage will drop on the passive power filter. In this way, the dc bus voltage and voltage rating of the power converter can be significantly reduced. However, the current of the power converter, including the harmonic currents of the load and the fundamental reactive current of the passive power filter, is not diminished. Although the shunt-type hybrid power filter can be applied to improve problems of the neutral-line current in three-phase four-line distribution power systems [21], it cannot attenuate the fundamental component of neutral-line current caused by the unbalanced load. In addition, the current of the power converter is not diminished yet. A new hybrid power conditioner for solving the problems of harmonic currents and neutral-line current in three-phase four-wire distribution power systems is proposed in this paper. This hybrid power conditioner is configured by a neutral-line current attenuator and a hybrid power filter. The hybrid power filter, configured by a three-phase power converter and a three phase tuned power filter, is utilized to filter the non-zero-sequence harmonic currents in the three-phase four-wire distribution power system.

The neutral-line current suppressor is connected between the power capacitors of the three-phase tuned power filter and the neutral line to attenuate the neutral-line current in the three-phase four-wire distribution power system. The proposed hybrid power conditioner can effectively reduce the power rating of passive and active elements. A hardware prototype is developed to verify the performance of the proposed hybrid power conditioner.

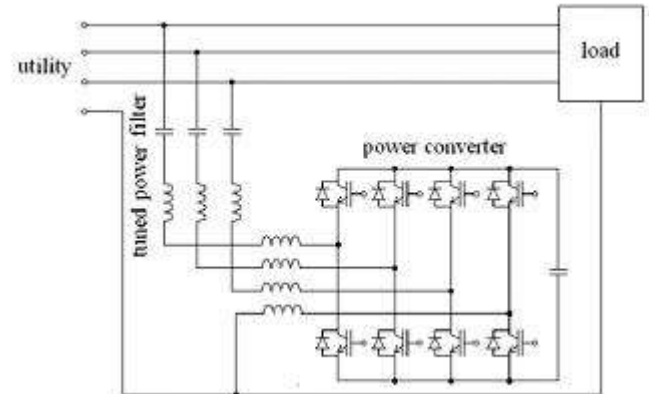

Fig. 1. Configuration of the conventional shunt-type hybrid power filter.

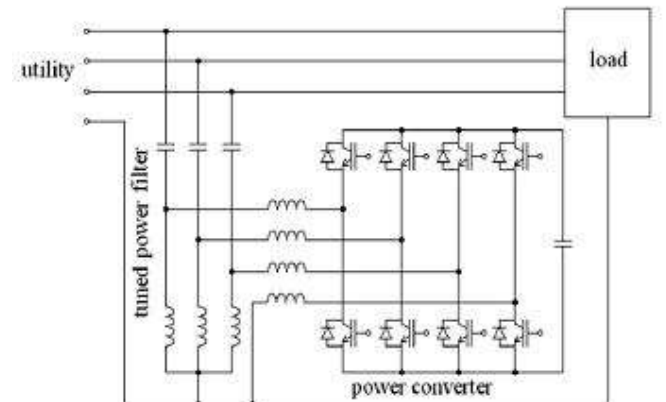
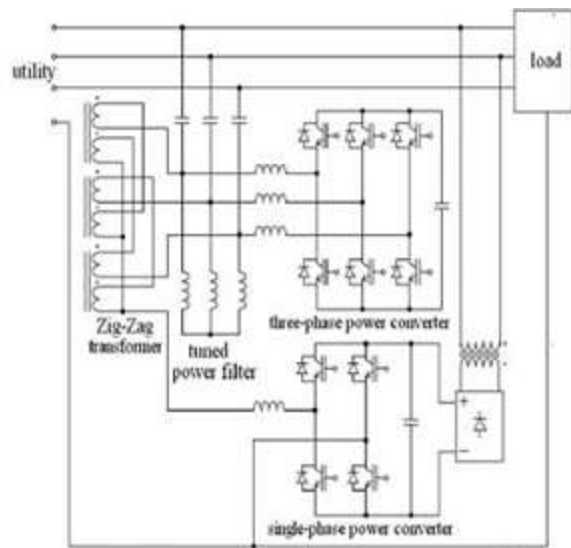

Fig. 2. Configuration of the advanced hybrid power filter.

## II. THREE-PHASE FOUR-WIRE HYBRID POWER FILTER

Fig. 1 shows the configuration of a conventional shunt-type hybrid power filter applied to the three-phase four-wire distribution power system. In the conventional shunt-type hybrid power filter, the power converter is connected to the passive power filter in series and then connected to the load in parallel. The power converter can be configured by a four-arm bridge structure or a three-arm bridge structure with a split-capacitor arm. The passive power filter is configured by three-phase tuned power filters with an inductor and a capacitor connected in series in each phase, and their tuned frequency is the dominant harmonic frequency of the load. The tuned frequency of the tuned power filters is designed at the third harmonic frequency in the application of three-phase four-wire distribution power systems.

As seen in Fig.1, the major part of the utility voltage will drop on the passive power filter. In this way, the dc bus voltage and voltage rating of the power converter can be significantly reduced. However, the current of the power converter, including the harmonic currents of the load and the fundamental reactive current of the passive power filter, is not diminished. An advanced hybrid power filter, shown in Fig. 2, is proposed to further reduce the power rating of the power converter. As seen in Fig. 2, the power converter is connected to the inductors of the three-phase tuned power filter in parallel. Since the power converter is parallel to the inductors of the tuned power filters, the major fundamental reactive current of the three-phase tuned power filter and the dominant harmonic current of the load will flow through the inductors of the three-phase tuned power filter by proper control of the power converter, thus decreasing the current flowing through the power converter.



**Fig.3. System configuration of the proposed hybrid power conditioner.**

The major role of the conventional shunt-type hybrid power filter applied to the three-phase four-wire distribution power system is to filter harmonic currents of the load. If the three phase loads are unbalanced, the neutral-line current of the load contains a fundamental component. The conventional shunt type hybrid power filter cannot respond to this fundamental component of the neutral-line current. Therefore, it cannot effectively suppress the neutral-line current under the unbalanced load.

### III. SYSTEM CONFIGURATION OF THE NEW HYBRID POWER CONDITIONER

Fig3 shows the system configuration of the proposed hybrid power conditioner. In comparison with the conventional hybrid power filter, a neutral-line current attenuator is integrated into the hybrid power filter in the proposed hybrid

power conditioner. The integrated neutral-line current attenuator can advance the filter performance of the hybrid power filter under the unbalanced load. Hence, the proposed hybrid power conditioner can simultaneously and effectively solve the problems of harmonic currents and neutral-line current in three-phase four-wire distribution power systems. To further reduce the power rating of the power converter, the advanced hybrid power filter is used with the three-phase power converter connected to the inductors of the three-phase tuned power filter in parallel. By incorporating the neutral-line current attenuator, the hybrid power filter is utilized to suppress only the nonzero-sequence harmonic currents in three-phase four-wire distribution power systems. Hence, the three-phase power converter is configured by a three-arm bridge structure and the tuned frequency of three-phase tuned power filter is set at the fifth harmonic frequency. With an increase in tuned frequency of the tuned power filters, the inductance of inductors can be reduced.

### IV. CONTROL PRINCIPLE

Current-mode control is adopted to control the three-phase power converter of the hybrid power filter. The output currents of the three-phase power converter are controlled to be harmonics, and the second term is for regulating the dc bus voltage of three-phase power converter. Since the three-phase power converter is parallel to the inductors of the three-phase tuned power filter and its output currents are controlled. The major fundamental reactive currents of the tuned power filters and the dominant harmonic currents of the load will flow through the inductors of the tuned power filters. Therefore, the currents flowing through the three-phase power converter can be effectively decreased.

The single-phase power converter of the neutral-line current attenuator is controlled by the general pulse width modulation(PWM).

### V. CONTROL BLOCK DIAGRAM

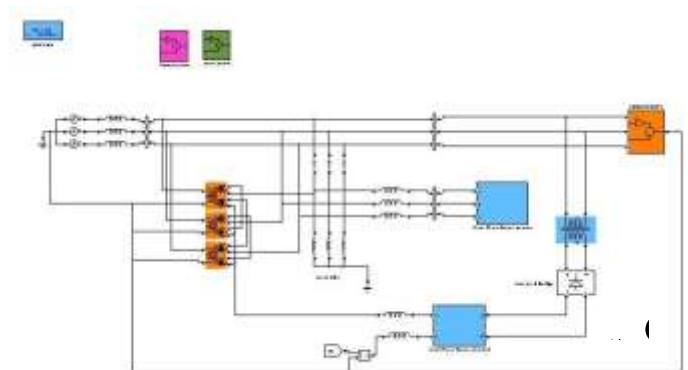

**Fig. 4 shows the simulation diagram the hybrid power conditioner under the unbalanced three phase load.**

The three-phase power converter adopts the current-mode control. The current references should be calculated first. The current references should be equal, and they contain a fundamental signal and a harmonic signal. The detected three-phase utility currents are sent to the band stop filters to extract their harmonic components. The outputs of the band stop filters are sent to the amplifier with gain, and the harmonic signals of the current references are then obtained. The detected dc bus voltage of the three-phase power converter is compared with the setting voltage, and the compared result is sent to a proportional-integral (PI) controller. The output of the PI controller is. Both the outputs of the PI controller and the detected three-phase utility voltages are sent to the multipliers so that the fundamental signals of the current references are obtained. The current references are obtained by summing up the harmonic signals and the fundamental signals.

### SIMULATION RESULTS

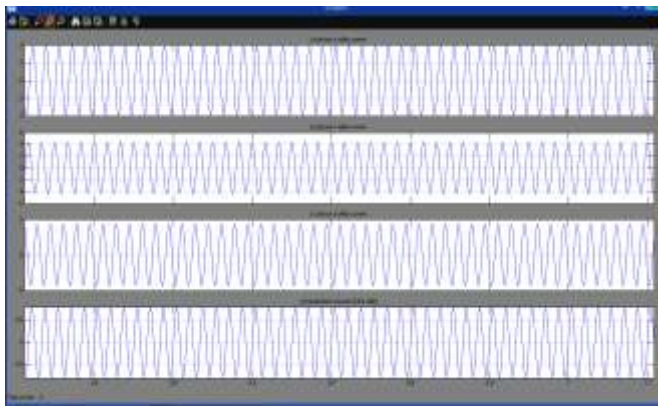

Fig 5. Simulation results of the hybrid power conditioner under the balanced three-phase load: (a) phase a utility current, (b) phase c utility current, (c) phase b utility current, and (d) neutral line current of the utility.

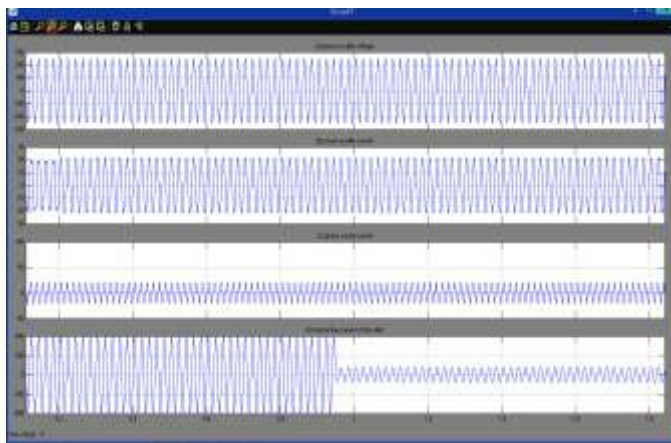

Fig 6. Simulation results of the three-phase four-wire hybrid power conditioner under the transient of applying the neutral-line current attenuator: (a) phase a utility voltage, (b) phase a utility current, (c) phase a load current, and (d) neutral line current of the utility.

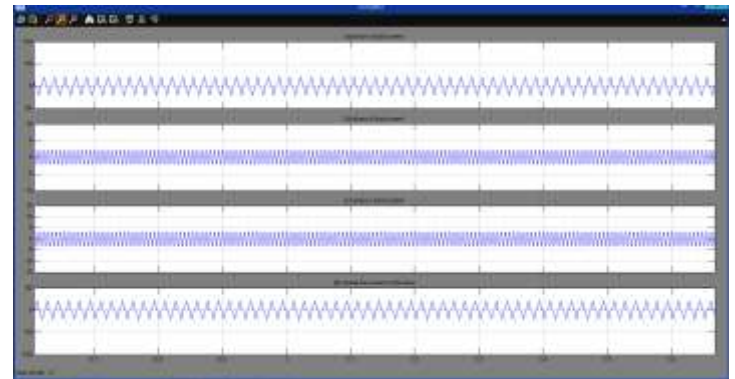

Fig 7. Simulation results of the hybrid power conditioner under the transient of increasing load: (a) phase a utility voltage, (b) phase a utility current, (c) phase a load current, and (d) neutral line current of the utility.

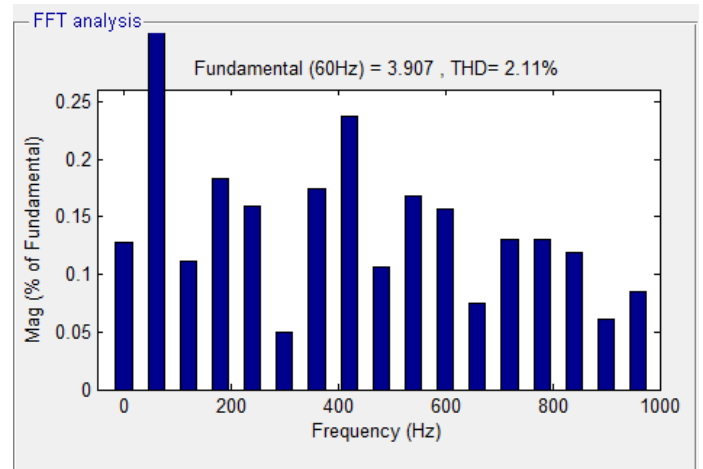

Fig 8. THD- hybrid power conditioner by pi controller under the transient of increasing load.

### Extension Results

In the Extension Total harmonic Distortions are reduced as shown in fig 12



Fig 9. Simulation results of the hybrid power conditioner by Fuzzy logic controller under the transient of increasing load: (a) phase a utility voltage, (b) phase a utility current, (c) phase a load current, and (d) neutral line current of the utility.

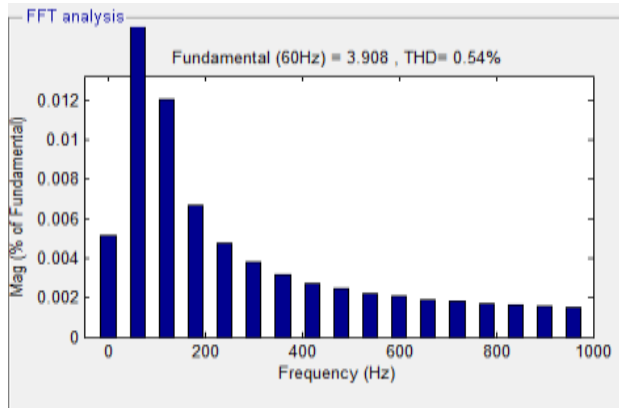

Fig 10. THD- hybrid power conditioner by fuzzy logic controller under the transient of increasing load

## VII. CONCLUSION

Three-phase four-wire distribution power systems have been widely applied to low-voltage applications; however, they encounter serious problems of harmonic current pollution and large neutral-line current. In this paper, a new hybrid power conditioner, composed of a hybrid power filter and a neutral-line current attenuator, is proposed. In the proposed hybrid power conditioner, the power capacity of power converters in the hybrid power filter and neutral-line current attenuator can be effectively reduced, thus increasing its use in high-power applications and enhancing the operation efficiency. A prototype is developed and tested. Experimental results verify that the proposed hybrid power conditioner can suppress the harmonic currents and attenuate the neutral-line current effectively whether the loads are balanced or not. Hence, the proposed hybrid power conditioner is an effective solution to the problems of harmonic currents and neutral-line current in three-phase four-wire distribution power systems. Besides, the output current of the three-phase power converter is much smaller than the conventional hybrid power filter, and the power rating of the zig-zag transformer is smaller than the rating of the conventional neutral-line current attenuator.

## IX. REFERENCES

- [1] B. Singh, P. Jayaprakash, T. R. Somayajulu, and D. P. Kothari, "Reduced rating VSC with a zig-zag transformer for current compensation in a three-phase four-wire distribution system," *IEEE Trans. Power Del.*, vol. 24, no. 1, pp. 249–259, Jan. 2009.
- [2] R. M. Ciric, L. F. Ochoa, A. Padilla-Feltrin, and H. Nouri, "Fault analysis in four-wire distribution networks," *Proc. Inst. Elect. Eng., Gen., Transm. Distrib.*, vol. 152, no. 6, pp. 977–982, 2005.

[3] J. C. Meza and A. H. Samra, "Zero-sequence harmonics current minimization using zero-blocking reactor and zig-zag transformer," in *Proc. IEEE DRPT*, 2008, pp. 1758–1764.

[4] H. L. Jou, J. C. Wu, K. D. Wu, W. J. Chiang, and Y. H. Chen, "Analysis of zig-zag transformer applying in the three-phase four-wire distribution power system," *IEEE Trans. Power Del.*, vol. 20, no. 2, pt. 1, pp. 1168–1178, Apr. 2005.

[5] S. Choi and M. Jang, "Analysis and control of a single-phase inverter zig-zag transformer hybrid neutral-current suppressor in three-phase four-wire systems," *IEEE Trans. Ind. Electron.*, vol. 54, no. 4, pp. 2201–2208, Aug. 2007.