

IMPROVEMENT OF POWER QUALITY IN DISTRIBUTION SYSTEM BY USING FACTS WITH SMES

V.SHAILAJA¹, A.NARASIMHA RAO² P.NAGESWARA RAO³

¹PG Scholar, Dept of EEE(PS), Vidya jyothi institute of technology Telangana, India.

²Associate Professor, Dept of EEE, Vidya jyothi institute of technology Telangana, India.

³Associate Professor, Dept of EEE, Vidya jyothi institute of technology Telangana, India.

ABSTRACT

The main aim of project is to improve the power quality in distribution system by using facts device with SMES unit. In existing system SMES unit is proposed to improve the dynamic performance of a wind energy conversion system equipped with DFIG during voltage sag and voltage swell events. The converter and the chopper of the SMES unit are controlled using a hysteresis current controller and a fuzzy logic controller, respectively. In proposed system a 12-pulse based Static Synchronous Series Compensator (SSSC) with and without Superconducting Magnetic Energy Storage (SMES) for enhancing the voltage stability. The Control scheme for the chopper circuit of SMES coil is designed. A three area system is taken as test system and the operation of SSSC with and without SMES is analysed for various transient disturbances in MATLAB / SIMULINK environment.

I. INTRODUCTION

One of the most promising renewable energy sources is wind energy, which has grown rapidly from about 2000 MW at the end of the year 1990 to 94000 MW by the end of the year 2007. The future prospects of the global wind industry are very encouraging, and it is estimated to grow

by more than 70% to reach 160 GW by the year 2012. It is estimated that, by the year 2020, wind power will supply at least 10% of global electricity demands. Owing to the rapid development of power electronics technology, the number of wind turbines equipped with converter stations has increased. The doubly fed induction generator (DFIG) is one of the most popular variable speed wind turbine generators (WTGs). In this technology, the rotor winding is connected to a coupling transformer through a back-to-back partial-scale voltage source converter (VSC), whereas the stator winding is directly connected to the grid at a point of common coupling (PCC) through the coupling transformer. The VSC decouples the mechanical and electrical frequencies and make variable-speed operation possible [3]. Global trend shows that the market share of the installed wind energy conversion system (WECS) has been dominated by DFIG-based wind turbines since 2002 [4]. In the earlier stages of integrating WECSs into the electricity grids, WTGs were disconnected from the grid during faults at the grid side to avoid any possible damages to wind turbines. Recently, existing WTGs, however, will have to be designed/managed to comply with the recent requirements of new grid codes

[5] to assure the continuity of supplying power to the grid during transient and abnormal operating conditions. Presently, FACTS devices are a viable alternative as they allow controlling voltages and current of appropriate magnitude for electric power system at an increasingly lower cost [3]. However, a comparable field of knowledge on FACTS/ESS control is quite limited. Therefore, in this work a methodology is proposed to control the power flow, which uses FACTS controllers with energy storage. Using switching power converter-based FACTS controllers can carry this out. Among the different modeling of FACTS devices, SSSC with SMES is proposed as the most adequate for the present application well discussed.

II. SUPER MAGNETIC ENERGY STORAGE SYSTEM

An SMES system consists of a superconductor coil, a power-conditioning system, a cryogenic refrigerator, and a cryostat/vacuum vessel to keep the coil at a low temperature required to maintain it in superconducting state. This configuration makes SMES highly efficient in storing electricity with typical efficiency in the range of 95%–98%. Other advantages of the SMES unit include very quick response and possibilities for high-power applications. A typical SMES configuration is shown in fig 1.

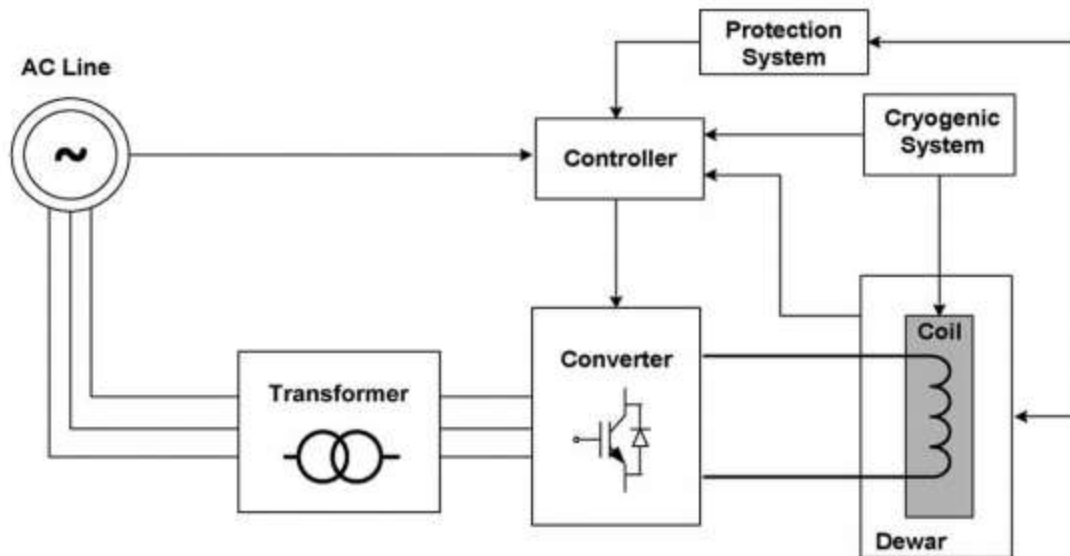

Fig. 1. Typical schematic diagram of an SMES unit

III. CONTROLLING OF SMES

There are two major configurations of SMES, i.e., current source converter (CSC) and VSC. Traditionally, CSC is connected through a 12-pulse converter configuration to eliminate the ac-side fifth and seventh harmonic currents and

the dc side sixth harmonic voltage, thus resulting in significant savings in harmonic filters [18]. However, because this configuration uses two 6-pulse CSCs that are connected in parallel, its cost is relatively high. The VSC, on the other hand, must be connected with a dc–dc chopper through a dc link, which facilitates energy

exchange between the SMES coil and the ac grid. Reference estimates the total cost of the switching devices of the CSC to be 173% of the switching devices and power diodes required for equivalent capacity of the VSC and the chopper. Moreover, a VSC has a better self-commutating capability, and it injects lower harmonic currents into the ac grid than a comparable CSC. The use of IGBTs in this configuration is more beneficial than GTO since the switching frequency of an IGBT lies on the range of 2–20 kHz, whereas, in case of GTO, the switching frequency cannot exceed 1 kHz. The stored energy in the SMES coil can be calculated as

$$E = \frac{1}{2} I_{SMES}^2 L_{SMES}$$

where E , I_{SMES} , and L_{SMES} are the stored energy, current, and coil inductance of the SMES unit, respectively.

IV. CASE STUDY OF EXISTING SYSTEM

The system under study shown in Fig. 2(a) consists of six 1.5-MW DFIGs connected to the ac grid at the PCC. The DFIG consists of an induction generator with stator winding connected directly to the grid through a Y/Δ step-up transformer, whereas the rotor winding is connected to a bidirectional back-to-back insulated gate bipolar transistor (IGBT) VSC, as shown in Fig. 2(b).

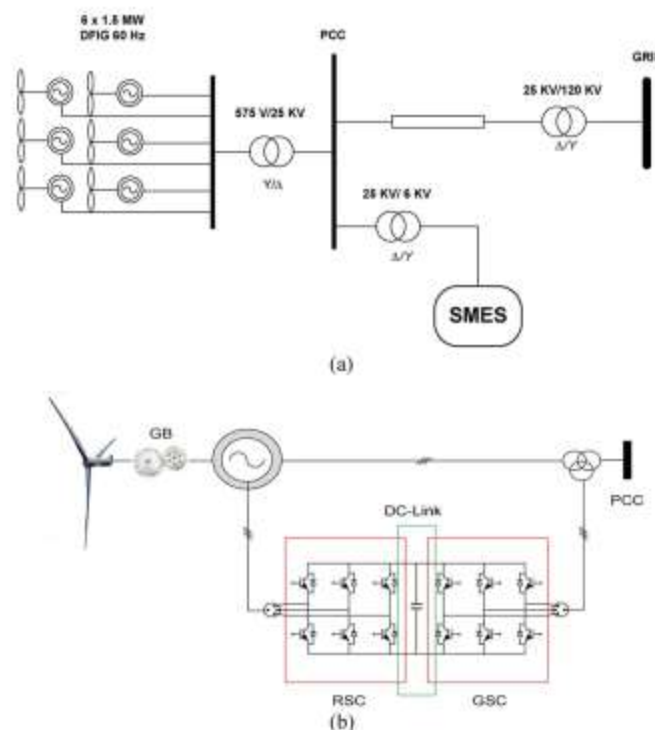

Fig. 2. (a) System under study. (b) Typical configuration of an individual DFIG.

TABLE I
 PARAMETERS OF THE DFIG

Duty Cycle (D)	SMES Coil Action
$D = 0.5$	standby condition
$0 \leq D < 0.5$	discharging condition
$0.5 < D \leq 1$	charging condition

TABLE II
 PARAMETERS OF THE TRANSMISSION LINE

Rated Power	9 MW (6 x @ 1.5 MW)
Stator Voltage	575 V
Frequency	60 Hz
R_S	0.023 pu
R_R	0.016 pu
V_{DC}	1150 V

The grid that is represented by an ideal three-phase voltage source of constant frequency is connected to the wind turbines via a 30-km transmission line and Δ/Y step-up transformer. The reactive power produced by the wind turbines is regulated at zero MVar under normal operating conditions. For an average wind speed of 15 m/s, which is used in this study, the

turbine output power is 1.0 pu, and the generator speed is 1.2 pu. The SMES unit is connected to the 25-kV bus and is assumed to be fully charged at its maximum capacity of 1.0 MJ Tables I and II. And in this we are using FLC technique. Fig shows the block diagram of SMES unit configuration and the proposed HCC–FLC control scheme

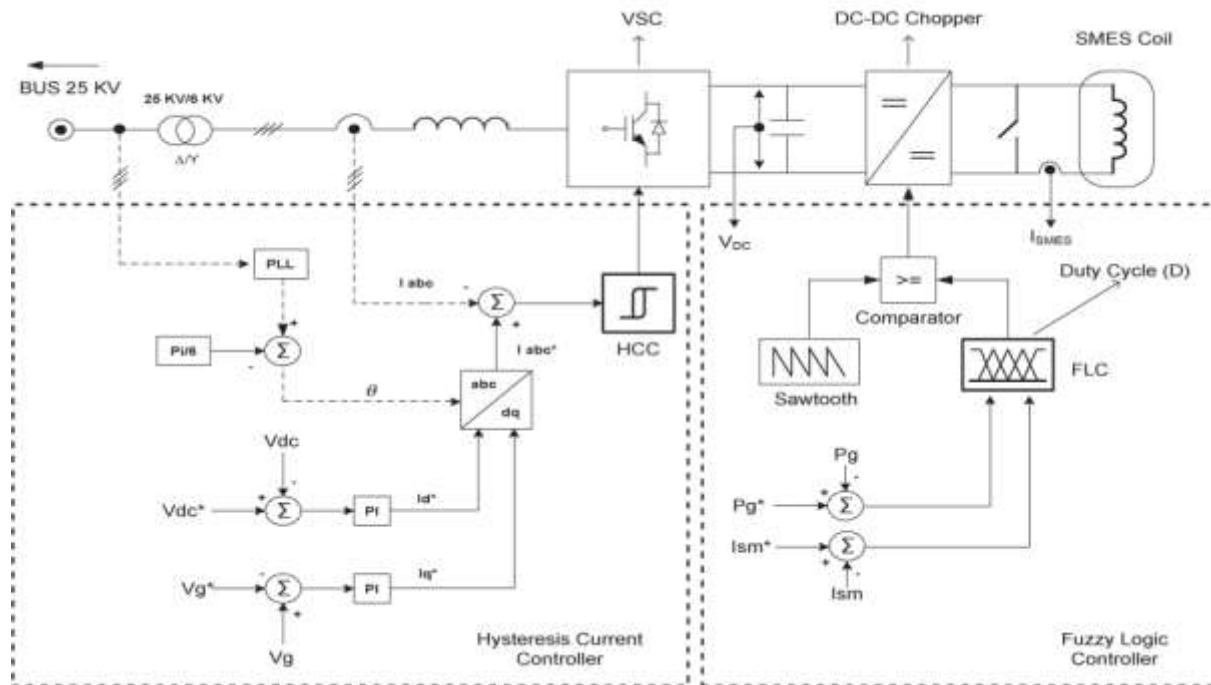

Fig. 3. SMES unit configuration and the proposed HCC–FLC control scheme.

IV. CASE STUDY OF PROPOSED SYSTEM

In proposed system SMES connected to a static synchronous compensator for improving the voltage stability. In this compensation works by works by increasing the voltage across the impedance of the given physical line, which in turn increases the

corresponding line current and the transmitted power. For normal capacitive compensation, the output voltage lags the line current by 90° . With voltage source inverters the output voltage can be reversed by simple control action to make it lead or lag the line current by 90° . The addition

of energy storage device is helpful in exchanging the real power. Without energy storage device, exchanging of real power is not

V. SIMULATION RESULTS

1) EXISTING RESULTS

efficient. The modeled SSSC circuit with its two six-pulse VSCs and their series transformers.

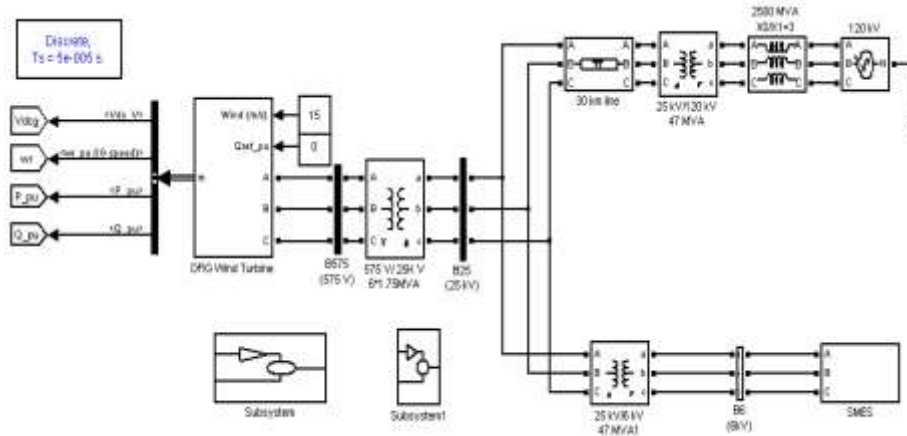

Fig 4. MATLAB/SIMULINK diagram of SMES unit configuration

Voltage Sag Event

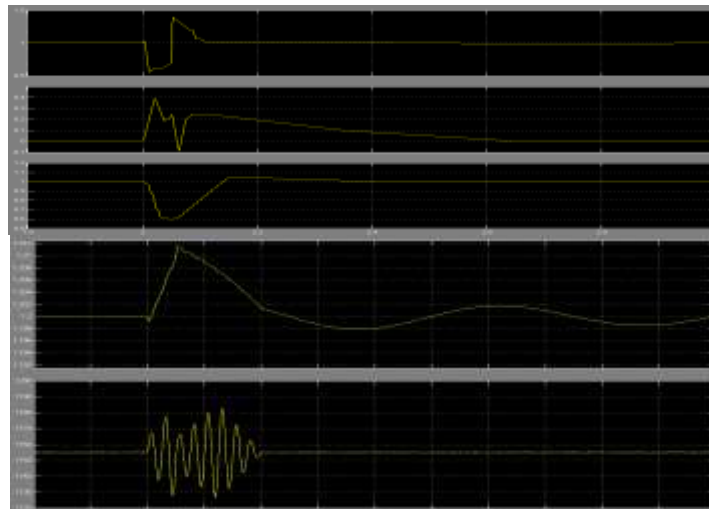

Fig. 5. DFIG responses during voltage sag without an SMES unit. (a) Active power. (b) Reactive power. (c) PCC voltage. (d) Shaft speed. (e) Voltage at the dc-link of the DFIG.

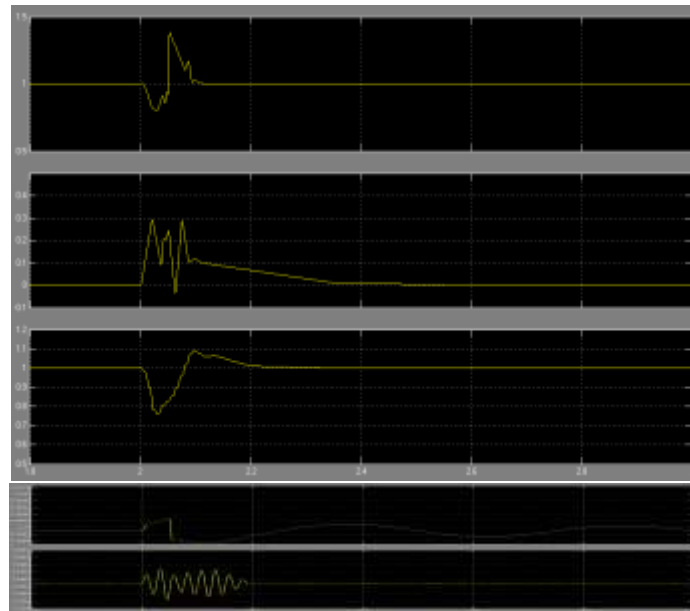

Fig6. DFIG responses during voltage sag with an SMES unit. (a) Active power. (b) Reactive power. (c) PCC voltage. (d) Shaft speed. (e) Voltage at the dc-link of the DFIG.

Voltage Swell Event

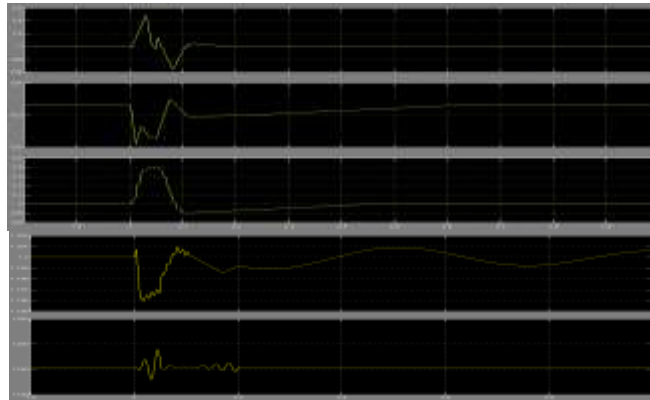

Fig.7. DFIG responses during voltage swell without an SMES unit. (a) Active power. (b) Reactive power. (c) PCC voltage. (d) Shaft speed. (e) Voltage at the dc-link of the DFIG.

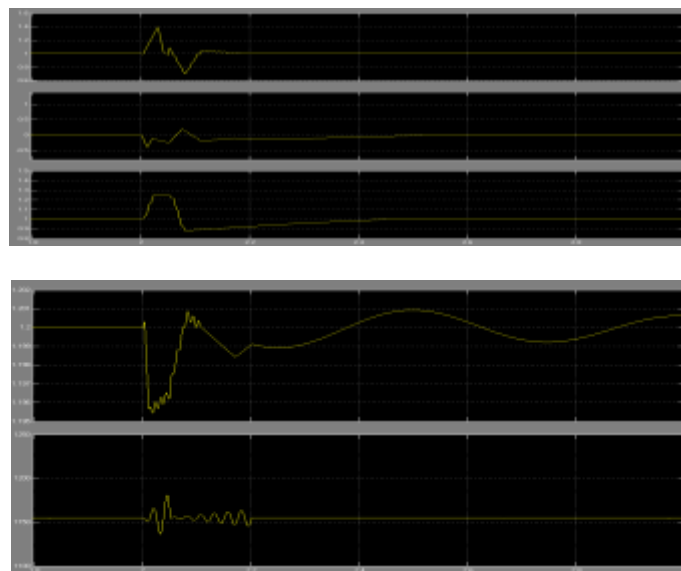

Fig.8. DFIG responses during voltage swell with an SMES unit.
(a) Active power. (b) Reactive power. (c) PCC voltage. (d) Shaft speed.
(e) Voltage at the dc-link of the DFIG.

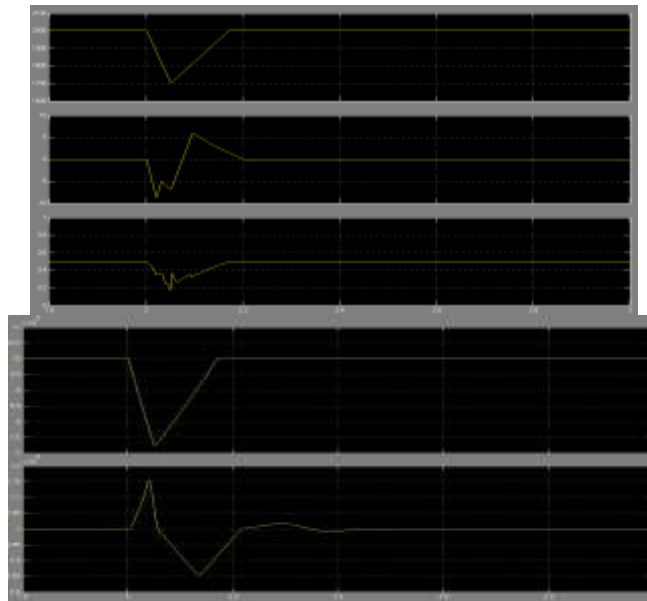

Fig.9 . SMES transient responses during voltage sag including (a) stored energy, (b) current, (c) voltage, (d) duty cycle, and (e) voltage at the dc-link of the SMES

2 EXTENSION RESULTS

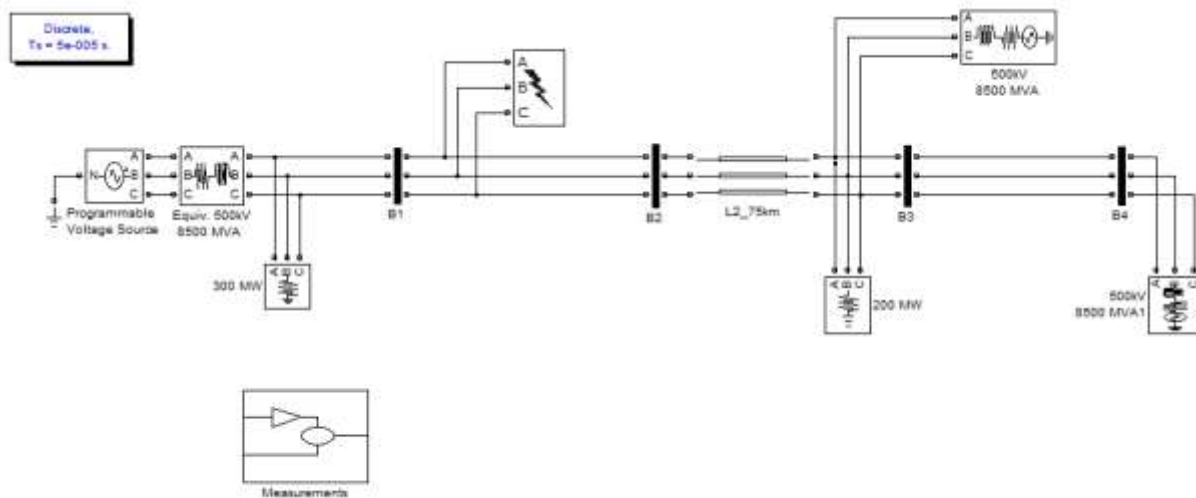

Fig 10. With out SMES during three phase fault

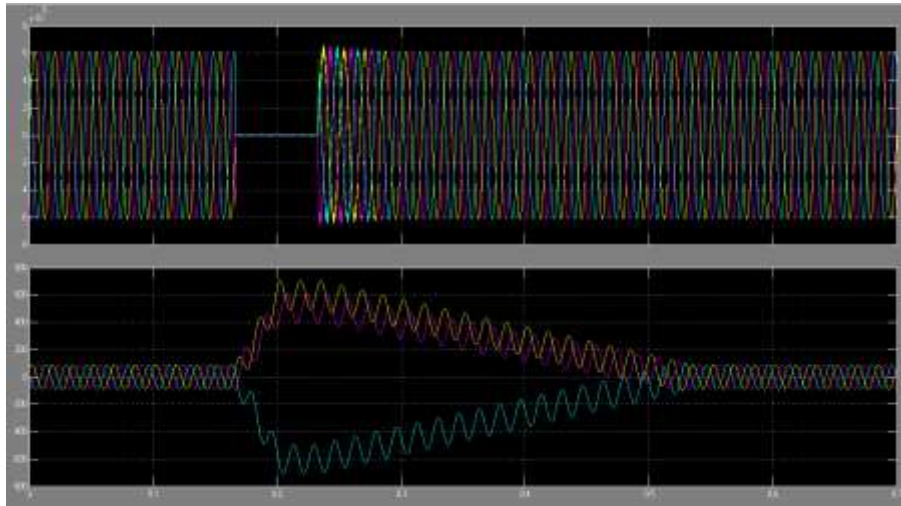

Fig 11 voltage at B1 and current at B2

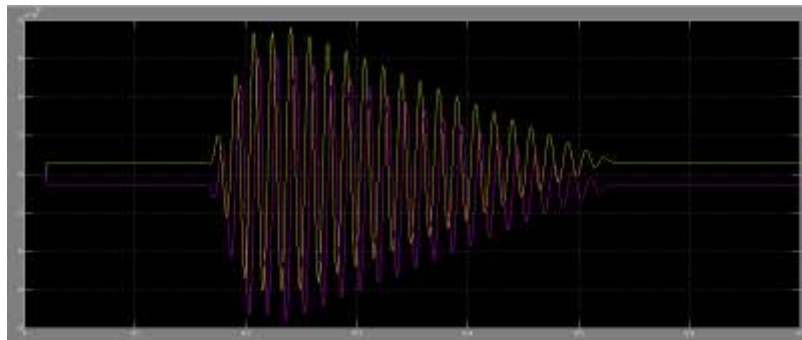

FIG 12 active power and reactive power during three phase fault without SMES

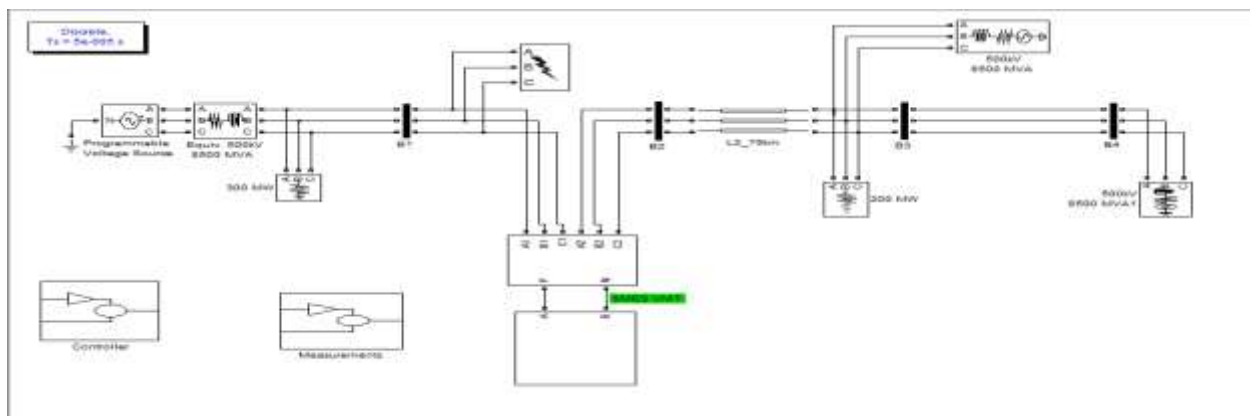

FIG 13 With SMES UNIT DURING SMES UNIT

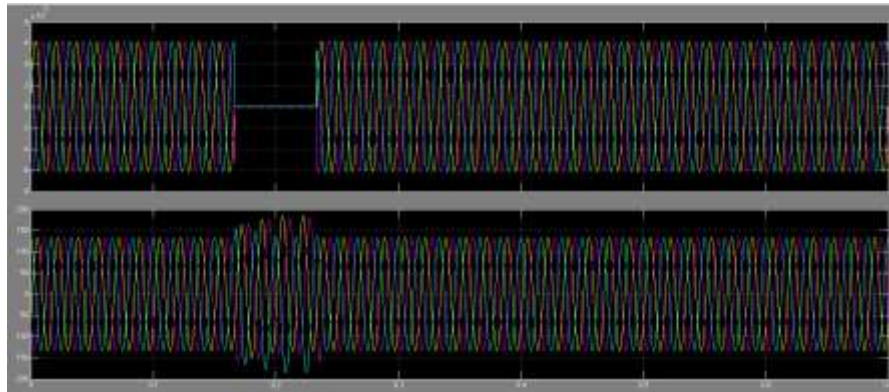

Fig 14 voltage at B1 and current at B2

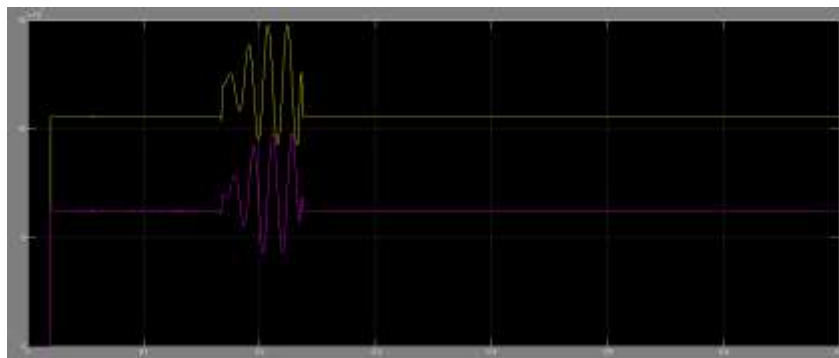

FIG 15 active power and reactive power during three phase fault with SMES

CONCLUSION

A new control algorithm along with a new application of the SMES unit to improve the transient response of WTGs equipped with DFIG during voltage sag and voltage swell events has been proposed. Simulation results have shown that the SMES unit is very effective in improving the dynamic performance of a power system with wind turbine equipped with DFIG during voltage sag and voltage swell at the grid side. The proposed control algorithm of the SMES unit is simple and easy to implement and is able to improve the FRT of the DFIG. The

SMES unit, on the other hand is still a costly piece of equipment; however, due to the development of high temperature superconducting materials, its application in power systems is expected to become viable in the near future.

Extension results shows The dynamic performance of the SSSC with and without SMES for the test system are analysed with Matlab/simulink. In the extension SMES with two quadrant chopper control plays an important role in real power exchange. SSSC with and without has been developed to improve transient

stability performance of the power system. It is inferred from the results that the SSSC with SMES is very efficient in transient stability enhancement.

REFERENCES

[1] S. S. Choi, F. Jiang and G. Shrestha, "Suppression of transmission system oscillations by thyristor controlled series compensation", IEE Proc., Vol.GTD-143, No.1, 1996, pp 7-12.

[2] M.W. Tsang and D. Sutanto, "Power System Stabiliser using Energy Storage", 0-7803-5935-6/00 2000, IEEE

[3] Hingorani, N.G., "Role of FACTS in a Deregulated Market," Proc. IEEE Power Engineering Society Winter Meeting, Seattle, WA, USA, 2006, pp. 1-6.

[4] J. M. Carrasco, L. G. Franquelo, J. T. Bialasiewicz, E. Galvan, R. C. P. Guisado, M. A. M. Prats, J. I. Leon, and N. Moreno-Alfonso, "Power-electronic systems for the grid integration of renewable energy sources: A survey," IEEE Trans. Ind. Electron., vol. 53, no. 4, pp. 1002–1016, Jun. 2006.

[5] T. Ackerman, Wind Power in Power System. West Sussex, U.K.: Wiley, 2005, p. 65.

[6] M. Tsili and S. Papathanassiou, "A review of grid code technical requirements for wind

farms," IET Renew. Power Gener., vol. 3, no. 3, pp. 308–332, Sep. 2009.

[7] S. Seman, J. Niiranen, and A. Arkkio, "Ride-through analysis of doubly fed induction wind-power generator under unsymmetrical network disturbance," IEEE Trans. Power Syst., vol. 21, no. 4, pp. 1782–1789, Nov. 2006.

[8] J. Lopez, E. Gubia, E. Olea, J. Ruiz, and L. Marroyo, "Ride through of wind turbines with doubly fed induction generator under symmetrical voltage dips," IEEE Trans. Ind. Electron., vol. 56, no. 10, pp. 4246–4254, Oct. 2009.

[9] M. Mohseni, S. M. Islam, and M. A. S. Masoum, "Impacts of symmetrical and asymmetrical voltage sags on DFIG-based wind turbines considering phase-angle jump, voltage recovery, and sag parameters," IEEE Trans. Power Electron., vol. 26, no. 5, pp. 1587–1598, May 2011.

[10] Y. Xiangwu, G. Venkataramanan, P. S. Flannery, W. Yang, D. Qing, and Z. Bo, "Voltage-sag tolerance of DFIG wind turbine with a series grid side passive-impedance network," IEEE Trans. Energy Convers., vol. 25, no. 4, pp. 1048–1056, Dec. 2010.

AUTHOR'S PROFILE

Engineering Department . His areas of interests are power systems & power electronics.



VASANKI SHAILAJA has received her B.Tech degree in Electrical and Electronics Engineering from Nagole institute of technology and science, Hyderabad, Telangana, and M.Tech in Power systems from Vidya jyothi institute of technology Telangana, India.



Mr.A.NARASIMHA RAO Working as Associate Professor at VJIT, Hyderabad since July 2013 Associate Professor from 2001 May to 2013 December MVSR Engineering College Manager (Software Development) 2000-2001

- a) Manage IT **Model Software** 1995-2000
- d) Systems Analyst in Singareni Collieries Company Limited from 1985 - 1995
- e) Associate faculty, Computer & MIS area, Administrative Staff
College of India, Hyderabad – 1980 -1985

Interested areas

M.Tech (Power Systems) from University College of Engineering, OU-1982

B.E. (Electrical) from University College of Engineering, OU-1976



Mr.P.Nageswara Rao is an associate professor working with Vidya Jyothi Institute of Technology, Hyderabad India in the Electrical and Electronics