

Photovoltaic Burp Charge System On Energy-Saving Configuration for Pv Systems under Different Scenario

*K.PADMA **R.CHANDER

*M.TECH Dept of EEE, CHAITANYA INSTITUTE OF TECHNOLOGY & SCIENCE

**Assoc. Prof Dept of EEE, CHAITANYA INSTITUTE OF TECHNOLOGY & SCIENCE

Abstract:

Solar power being the primary source of energy is of main focus in field of energy conversion. The techniques to generate maximum power from simple PV-module are the major challenge. Power electronics have helped to obtain the goal to a greater extent. In this paper attempt have been made to study and analyze different MPPT techniques used in different scenarios to make it simple to choose a particular methodology for particular situation. Keywords: MPPT, Partial Shading Condition, P-V Systems, V-I Characteristics.

Keywords:MPPT.

I. INTRODUCTION

The world energy scenario is changing abruptly. The huge power demand the world face is becoming a challenge to human day by day. Technology improvements have helped to face this situation better, but it also have created other more challenges regarding the quality of power and

efficiency. The conventional energy sources that we relied upon are in stage of being replaced by the renewable energy sources that are widely available. Recent researches focus mainly on the solar energy that almost all the part of this world receives abundantly with variation in its potential. Many studies have made it possible to convert these energies in to more efficient electrical energy. The intervention of power electronics in almost of all the fields have made more sophistication in industries with loads that require the most efficient and accurate amount of supply. The terminology Maximum power point tracking came in to existence with all these conditions. MPPT is a method to obtain the maximum power from a module in any weather condition. As solar energy is varying in nature, the MPPT is the main focus of energy conservation. By the V-I characteristics of solar energy, there is only one point in its curve where the maximum power is achieved. Tracking that particular point with accuracy has developed

many algorithms in this field. Just as the energy that is variable, the techniques used to track the MPP vary under different circumstances. All algorithms will not suit every module in general. Thus choosing an appropriate MPPT technique is also a big deal in this scenario. Wide studies are being made regarding the techniques that are to be chosen for particular circuit or system. In this paper a trial is made to analyze various situations and the techniques used, to give a brief study in that area.

II. REVIEW ON MPPT TECHNIQUES

Many algorithms are formulated for PV system. The main aim is to find the point in the V-I characteristics of the solar panel, at which the product of Voltage and current is maximum. It is found that there is only one point in the curve at particular temperature and irradiation condition.

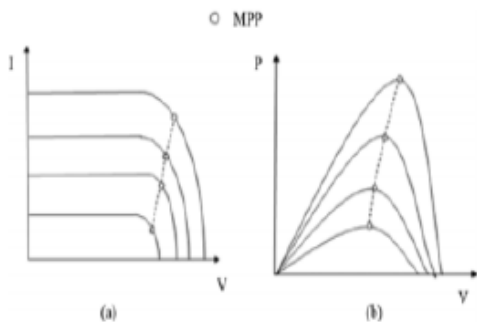

Fig1. (a) V-I characteristics (b) P-V characteristics of PV panel at different environmental conditions.

As the solar energy is a promising form of energy to meet our power demand, technology improvement is required to keep

the power generated from PV panels to be maximum at all weather conditions. Many algorithms are being developed to find the maximum point of power obtained from a cell, module and hence a panel. Efficiency of a module:

$$\eta_{MPPT} = \frac{P_{PV}}{P_{MPP}} \times 100 \tag{1}$$

Out of several algorithms only few delivers the MPP at all conditions for particular system. Brief descriptions of widely used algorithms are made.

A. Perturb and observe method

This is the basic hill climbing algorithm used. First the PV voltage and current are measured and the corresponding power is calculated. A small perturbation of voltage or duty cycle of the dc/dc converter, in one direction is considered and corresponding power is calculated. The two power values are then compared. If power calculated after perturbation is more than first, then the perturbation is in the correct direction; otherwise it should be reversed. In this way, the peak power point is recognized and hence the corresponding voltage can be calculated. P&O/hill-climbing show occasional deviation from the maximum operating point in case of rapidly changing atmospheric conditions. The perturbation size is important in providing good

performance in both dynamic and steady-state response. To achieve better result an adaptive hill climbing technique, with a variable perturbation step size can be formulated, where an automatic tuning controller varies the perturbation step size according to the environmental condition.

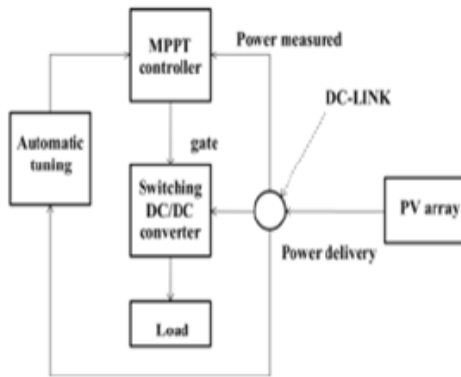

Fig2. Schematic representation of Adaptive Perturb and Observe method.

In the Adaptive P&O method, instead of VR mppR the main emphasis has been given on the voltage perturbation. A constant duty cycle perturbation that shows linear- inverse response to power drawn from PV panel has been taken in Predictive and Adaptive MPPT P&O method.

B. Incremental Conductance method

For a PV system, the derivative of panel output power with its voltage is expressed as

$$\frac{dP}{dV} = \frac{d(IV)}{dV} = I + V \frac{dI}{dV} = I + V \frac{\Delta I}{\Delta V} = 0 \text{ at MPP} \quad (2)$$

Certain conditions can be considered to track the direction of MPP

$$\frac{\Delta I}{\Delta V} = \frac{-I}{V} \text{ at MPP}$$

$$\frac{\Delta I}{\Delta V} > \frac{-I}{V} \text{ at left of MPP}$$

$$\frac{\Delta I}{\Delta V} < \frac{-I}{V} \text{ at right of MPP}$$

MPP can be tracked by comparing the instantaneous (I/V) conductance to the incremental conductance ($\Delta I/\Delta V$). This algorithm is similar to perturb and observe method which require variable step size to obtain proper Perturbation size .But it requires complex and costly control circuits

C. Ripple Co-relation Control technique

The switching action of the converter imposes voltage and current ripple on the generated power of PV system when it is connected to a power converter. This ripple can be utilized by the system to perform MPPT. No artificial perturbation is required as the ripple is naturally available by using a switching converter, these can be expressed as:

$$\frac{dv}{dt} > 0 \text{ or } \frac{di}{dt} > 0 \text{ and } \frac{dp}{dt} > 0 \Rightarrow V < V_{mpp} \text{ or } I < I_{mpp}$$

$$\frac{dv}{dt} > 0 \text{ or } \frac{di}{dt} > 0 \text{ and } \frac{dp}{dt} < 0 \Rightarrow V > V_{mpp} \text{ or } I > I_{mpp}$$

RCC correlates dp/ dt with either di/ dt or dv /dt and using the value of voltage and current of PV system are recognized whether more or less than that of MPP. RCC method forces the ripple to zero and

eventually drag the PV panel parameters to MPP

D. Fractional V or I method: V_{mpp} can be calculated from the empirical relationship: $V_{mpp} \approx V_{oc} \cdot K_{oc}$ (3) K_{oc} be calculated by analyzing the PV system at wide range of solar radiations and temperatures. For a fraction of second, the load end of PV system is open circuited and V_{oc} is measured, then V_{mpp} is calculated. This process is repeated and value of is updated.

E. Intelligent MPPT techniques Fuzzy Logic (FL)-Based MPPT Technique: The soft computing techniques achieved very good performances, fast responses with no overshoot, and less fluctuations in the steady state for rapid temperature and irradiance variations. The exact PV model is not required in FL-based MPPT. Mostly FLbased MPPT has two inputs and one output. The two input variables are error (e) and change (C_e) in error at the k th sampled time are defined as follows:

$$e(k) = \frac{dP}{dV}(k) - \frac{dP}{dV}(k-1) \quad (4)$$

$$C_e(k) = e(k) - e(k-1) \quad (5)$$

$e(k)$: implies if the error of position of operating point of load at the kR thR instant, while CR $eR(k)$ expresses the moving

direction of this point. The fuzzy inference is carried out by using Mamdani's method and the defuzzification uses the centre of gravity to compute the output (duty ratio) of this fuzzy logic-based MPPT

Artificial Neural Network(ANN) Based MPPT Technique: ANN requires no detailed information about the PV system. The link between the i th and j th nodes has weight w_{ij} .



Fig3. Schematic representation of Two inputs and one output based FL-MPPT.



Fig 4. Flow chart of modified PSO technique.

The efficiency of the system improves with number of hidden layers. Its identical to the brain function, which adapts to the situations with past and present inputs.

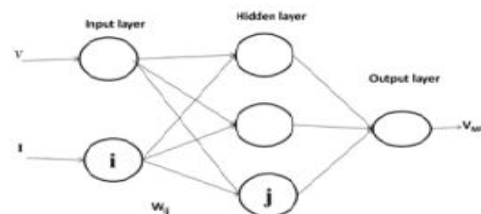

Fig5. Basic representation of neural network.

F. Improved Particle Swarm Optimization

In Multi-PV array structures during partial shaded condition multiple maxima are found in its V-I characteristics. An evolutionary computing approach called PSO has been employed for the multi-PV array structure to handle this situation. PSO works efficiently in multivariable problem with multiple maxima. Improved maximum power point tracking (MPPT) method for the photovoltaic (PV) system using a modified particle swarm optimization (PSO) algorithm can improve its efficiency. The main advantage of the method is once the maximum power point (MPP) is located; the steady state oscillation is reduced to practically zero and can track MPP for the extreme environmental condition

III. SUMMARY OF CONTRIBUTIONS

Many algorithms are being developed for MPPT. From the basic study, the main algorithm used in almost all applications is the Perturb and observe method. For a digitally controlled DC grid system this algorithm could show an efficiency of 99.5% [8]. By comparing the perturb parameter used OF P&O method as voltage or direct duty ratio for standalone PV pumping application, the D.D.R perturb method was found to perform better [19]. In area where more than one energy source is used, the P&O algorithm finds its enhanced way to track the MPP for boost converter

along with timebased power monitor, giving an efficiency of 83%.[7]. The efficiency of P&O, wanted a modified algorithm to achieve recovered results for different circuits. The perturbation made in this algorithm is fixed which cannot be utilized for converters other than conventional boost converter. But varying the method or parameter of perturbation it was able to use in different cases. With adaptive frequency perturbation, the system with single sensor PV module achieved more efficiency when compared to other algorithms like Inc. Conductance, Ripple Co-relation Control (RCC) Fractional V or I method and Neural Network with fixed perturbation and requiring multiplication factor [1]. For frequency modulated resonant LLCmicro-converter the centre point perturbation methods is more valid. [10]. Later on for further applications the P&O method was integrated with other algorithms to find a better MPP. The analog MPPT method established to be accurate than the conventional. Analog MPPT method combined with the existing was found to give an efficiency of 97.3% with slope detection algorithm and P&O. [18]. For DSP based stand alone system with dual MPPT configuration, the P&O integrated with Fuzzy Logic achieved a greater Convergence speed and reduced Steady state

oscillation [17]. Comparison between P&O and fuzzy logic along with PID was made in particular area of Algeria. The study found that P&O method achieved its stability in 9s and fuzzy logic for 5s. with PID the voltage regulation was achieved to maximum efficiency [2]. For energy harvesting small rating of solar modules the power dissipated through the switches effect the efficiency.

The fractional open circuit method with P&O helped to reduce the power utilized by the tracking system and to improve the system effectiveness [6]. Above all the partial shading conditions on PV panel have reduced the competence in MPP tracking. The fuzzy logic integrated with PID was analyzed on varying irradiance and temperature conditions.

The PID controller performed well during partial shading conditions [13]. Incremental conductance algorithm finds its efficiency in systems with interleaved-boost converters, [14] for energy saving smart charger circuits [21] and in parallel power processing topology [20]. By analyzing the P&O and Inc. Cond. algorithm, they both show only 0.02% and 0.13 variations in its steady state performance and dynamic response respectively. Revealing that both the methods are mathematically equal [15]. The non-uniform radiation effects of the MPP

have been discussed earlier. Now for non-uniform panel shape the normal algorithm will not help. The hybrid chaotic PSO implemented has proved to be capable in tracking the global MPP for flexible PV system with conventional boost converter.[3]. For different inverter topologies the MPPT techniques used will vary. For module integrated inverter, a new approach of model based MPPT showed up with more efficiency. With single-series-diode circuit the improved model based MPP ensures better dynamic performance Instead of using Pyranometer [4]. To estimate the global MPP the power rectangle is to be estimated using online sweeping technique. The MPP is achieved considering the effect of characteristic resistance which is obtained by either P&O or fractional voltage method. But the new approach of analysis of V-I characteristics with Power Plane analysis(PPA) method have shown better steady state performance [9]. Improved PSO algorithm also helps in achieving both local and global MPP even during partial shading conditions with less oscillations[5]. With all these algorithms to achieve MPP, New studies have started to implement control algorithms to enhance the working of MPPT algorithms. This has shown its ability with the intervention of soft computing techniques. By

implementing a bypass circuit along with boost convert the response time for MPP was improved [11]. Model reference adaptive control method with Lyapunov approach reduced the complexity in dealing with uncertain perturbations required to achieve the accurate MPP. [12].The hybrid algorithms are used to match the internal resistance of panel and load resistance to get the maximum power. Genetic algorithm is used to train artificial neural network based MPPT technique with its optimized values [22]. The accuracy and tracking speed is one of the dominant factors to choose MPPT technique. For applications that need fast tracking with accuracy, power increment technique can be used. Load-line MPPT techniques can be used for cost-effective and simple systems. Techniques such as ANN, DIRECT and APPSO are relatively complex and computationally inefficient. With a specific pattern of the power– voltage curve techniques such as Fibonacci search are only functional. The MPPT techniques vary with varied topology [16].

IV. CONCLUSION

The Increased power demand paved the way to invent new technologies to improve the power obtained from renewable energy sources. From various studies the hill climbing algorithms such as perturb and

observe and incremental conductance is seen to be better than all other MPPT algorithms. The efficiency is high in perturb and observe and Incremental conductance methods Though soft computing techniques like fuzzy and neural networks are developing. Individual MPPT for each PV module differ in varying circuit topologies. For stand alone and grid connected systems with conventional converters perturb and observe method finds its better performance. For improvised or resonant inverters, modified P&O methods need to be included. Improved PSO is been utilized mainly in partial shaded conditions and to reduce oscillations. The different algorithms are made used in different topologies of converters. Choice of algorithms and topologies depends upon the requirement. Above all control algorithms are emerging in to field to improve the efficiency of the existing MPPT algorithms. Hybrid algorithms are being developed to meet the demand of power even during partial shading or dark conditions. Advancement in this field deals with improving the existing algorithms by either simplifying it or merging with other algorithms to achieve more efficiency cost effectively.

V. REFERENCES

[1] Yuncong Jiang, Jaber A. Abu Qahouq and Tim A. Haskew, —Adaptive Step Size With Adaptive Perturbation-Frequency Digital MPPT Controller for a Single-Sensor Photovoltaic Solar System, IEEE transactions on power Electronics, vol. 28, no. 7, July 2013.

[2] Mhamed Rebhi, Ali Benatillah, Mabrouk Sellam and Boufeldja Kadri, —Comparative Study of MPPT Controllers for PV System Implemented in the Southwest of Algeria, Energy Procedia 36 (2013) 142 – 153.

[3] Christos Konstantopoulos and Eftichios Koutroulis, —Global Maximum Power Point Tracking of Flexible Photovoltaic Modules, IEEE transactions on Power Electronics, vol. 29, no. 6, June 2014.

[4] Loredana Cristaldi, Marco Faifer, Marco Rossi and Sergio Toscani, —An Improved Model-Based Maximum Power Point Tracker for Photovoltaic Panels, IEEE transactions on instrumentation and measurement, vol. 63, no. 1, January 2014.

[5] Kashif Ishaque, Zainal Salam, Muhammad Amjad, and Saad Mekhilef, —An Improved Particle Swarm Optimization (PSO)–Based MPPT for PV

with Reduced Steady-State Oscillation, IEEE Transactions on Power Electronics, Vol. 27, No. 8, August 2012

[6] Oscar López-Lapeña, Maria Teresa Penella, and Manel Gasulla, —A New MPPT Method for Low-Power Solar Energy Harvesting, IEEE Transactions On Industrial Electronics, Vol. 57, No. 9, September 2010 .

[7] Saurav Bandyopadhyay, and Anantha P. Chandrakasan, —Platform Architecture for Solar, Thermal, and Vibration Energy Combining With MPPT and Single Inductor, IEEE Journal of Solid-State Circuits, Vol. 47, No. 9, September 2012.\

AUTHOR 1:-

* K.PADMA completed her B tech in SRI CHAITANYA INSTITUTE OF TECHNOLOGICAL SCIENCES in 2014 and completed M-Tech in CHAITANYA INSTITUTE OF TECHNOLOGICAL & SCIENCE

AUTHOR 2:-

**R.CHANDER is working as Associate professor in Dept of EEE, CHAITANYA INSTITUTE OF TECHNOLOGICAL & SCIENCE