



Fuzzy Logic based Torque Ripple Minimization and PFC of BLDC Drive using Bridgeless- Luo Converter

MAHESH BABU BONTHU

Department of Electrical & Electronics Engineering,
Narsimha Reddy Engineering College,
Maisammaguda;
Rangareddy (Dt); Telangana, India.
Email: babumahesh149@gmail.com

G.SUHASINI

Assistant Professor
Department of Electrical & Electronics Engineering,
Narsimha Reddy Engineering College, Maisammaguda;
Rangareddy (Dt); Telangana, India.
Email: guthi.suhasini@gmail.com

YADAM NAGENDRA

Assistant Professor
Department of Electrical & Electronics Engineering,
Narsimha Reddy Engineering College, Maisammaguda;
Rangareddy (Dt); Telangana, India.
Email: withnagendra@gmail.com

Abstract- A PFC based BL-Luo converter-fed BLDC motor drive has been proposed for a wide range of speeds and supply voltages. A single voltage sensor-based speed control of the BLDC motor using a concept of variable dc-link voltage has been used. The PFC BL-Luo converter has been designed to operate in DICM and to act as an inherent power factor pre-regulator. An electronic commutation of the BLDC motor has been used which utilizes a low-frequency operation of VSI for reduced switching losses. The speed of the BLDC motor is controlled by an approach of variable dc-link voltage, which allows a low-frequency switching of the voltage source inverter for the electronic commutation of the BLDC motor, thus offering reduced switching losses. The proposed BLDC motor drive is designed to operate over a wide range of speed control with an improved power quality at ac mains. Fuzzy logic controller, in most instances, provides a superior performance to PI controller. However, it needs to be trained properly; anything that doesn't pertain to the behavior of intended system will fail you. Fuzzy is more forgiving than PI when the system deviates from its expected operating state. Fuzzy logic is widely used in machine control. The term "fuzzy" refers to the fact that the logic involved can deal with concepts that cannot be expressed as the "true" or "false" but rather as "partially true". Although alternative approaches such as genetic algorithms and neural networks can perform just as well as fuzzy logic in many cases, fuzzy logic has the advantage that the solution to the problem can be cast in terms that human operators can understand, so that their experience can be used in the design of the controller. The proposed concept can be implemented to fuzzy based torque ripple minimization MATLAB/SIMULINK software.

Index Terms—Bridgeless Luo (BL-Luo) converter, brushless dc (BLDC) motor, power factor correction (PFC), power quality, voltage source inverter (VSI).

I. INTRODUCTION

Since 1980's a new plan idea of changeless magnetbrushless engines has been created. The Changeless magnet brushless engines are ordered into two sorts based upon the back EMF waveform, brushless Air conditioning (BLAC) and brushless DC (BLDC) engines [1-2]. BLDC engine has trapezoidal

back EMF and semi rectangular current waveform. BLDC engines are quickly getting to be well known in businesses, forexample, Appliances, HVAC industry, restorative, electric footing, car, airplanes, military gear, hard plate drive, mechanical computerization gear and instrumentation due to their high effectiveness, high power element, noiseless operation, minimized, dependability and low support [3-5]. To supplant the capacity of commutators and brushes, the BLDC engine requires an inverter and a position sensor that distinguishes rotor position for legitimate substitution of current. The revolution of the BLDC engine is in light of the criticism of rotor position which is gotten from the corridor sensors [6]. BLDC engine ordinarily employments three lobby sensors for deciding the recompense Grouping. In BLDC engine the force misfortunes are in the stator where warmth can be effectively exchanged through the edge or cooling frameworks are utilized as a part of expansive machines [7-8]. BLDC engines have numerous focal points over DC engines and prompting engines. A percentage of the favorable circumstances are better speed versus torque qualities, high element reaction, high proficiency, long working life, quiet operation; higher pace ranges [9]. Up to now, more than 80% of the controllers are PI (Relative and vital) controllers on the grounds that they are effortless and straightforward. The velocity controllers are the routine PI controllers and current controllers are the P controllers to accomplish superior commute [10]. Can be considered as scientific hypothesis joining multi esteemed rationale, likelihood hypothesis, and counterfeit consciousness to recreate the human approach in the arrangement of different issues by utilizing an estimated thinking to relate diverse information sets and to make choices [11]. It has been accounted for that fluffy controllers are more powerful to plant parameter changes than traditional PI or controllers and have better clamor dismissal capacities [12].

This paper presents a BL Luo converterfed BLDC motor drive with variable dc link voltage of VSI for improved power quality at ac mains with reduced

components and superior control [13].

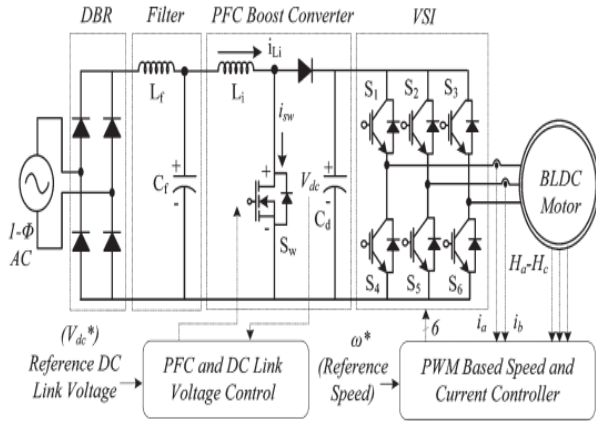

Fig. 1. Conventional PFC-based BLDC motor drive.

II. PROPOSED PFC-BASED BLDC MOTOR DRIVE

Fig. 2 shows the proposed PFC-based bridgeless Luo (BL-Luo) converter-fed BLDC motor drive. A single phase supply followed by a filter and a BL-Luo converter is used to feed a VSI driving a BLDC motor. The BL-Luo converter is designed to operate in DICM to act as an inherent power factor preregulator. The speed of the BLDC motor is controlled by adjusting the dc-link voltage of VSI using a single voltage sensor. This allows VSI to operate at fundamental frequency switching (i.e., electronic commutation of the BLDC motor) and hence has low switching losses in it, which are considerably high in a PWM-based VSI feeding a BLDC motor. The proposed scheme is designed, and its performance is simulated for achieving an improved power quality at ac mains for a wide range of speed control and supply voltage variations. Finally, the simulated performance of the proposed drive is validated with test results on a developed prototype of the drive.

III. OPERATING PRINCIPLE OF PFC BL-LUO CONVERTER

The operation of the proposed PFC BL-Luo converter is classified into two parts which include the operation during the positive and negative half cycles of supply voltage [see Fig. 3(a)–(c) and (d)–(f)] and during the complete switching cycle.

A. Operation during Positive and Negative Half Cycles of Supply Voltage

Fig. 3(a)–(c) and (d)–(f) shows the operation of the PFC BL-Luo converter for positive and negative half cycles of supply voltage, respectively. The bridgeless converter is designed such that two different switches operate for positive and negative half cycles of supply voltages. As shown in Fig. 5(a), switch Sw1, inductors Li1 and Lo1, and diodes Dp and Dp1 conduct during the positive half cycle of supply voltage. In a similar manner, switch Sw2, inductors Li2 and Lo2, and diodes Dn and Dn1 conduct during the negative half cycle of supply voltage as shown in Fig. 5(d). Fig. 6(a) shows the associated waveforms demonstrating the variation of different parameters such as supply voltage (vs), discontinuous input inductor currents (iLi1 and iLi2),

output inductor current (iLo1 and iLo2), and the intermediate capacitor’s voltage (VC1 and VC2) during the complete cycle of supply voltage.

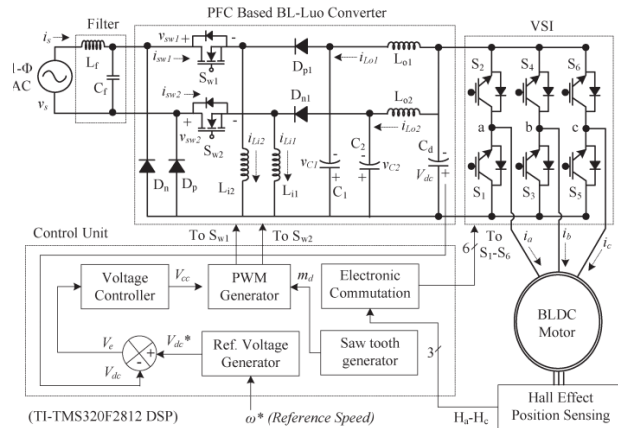
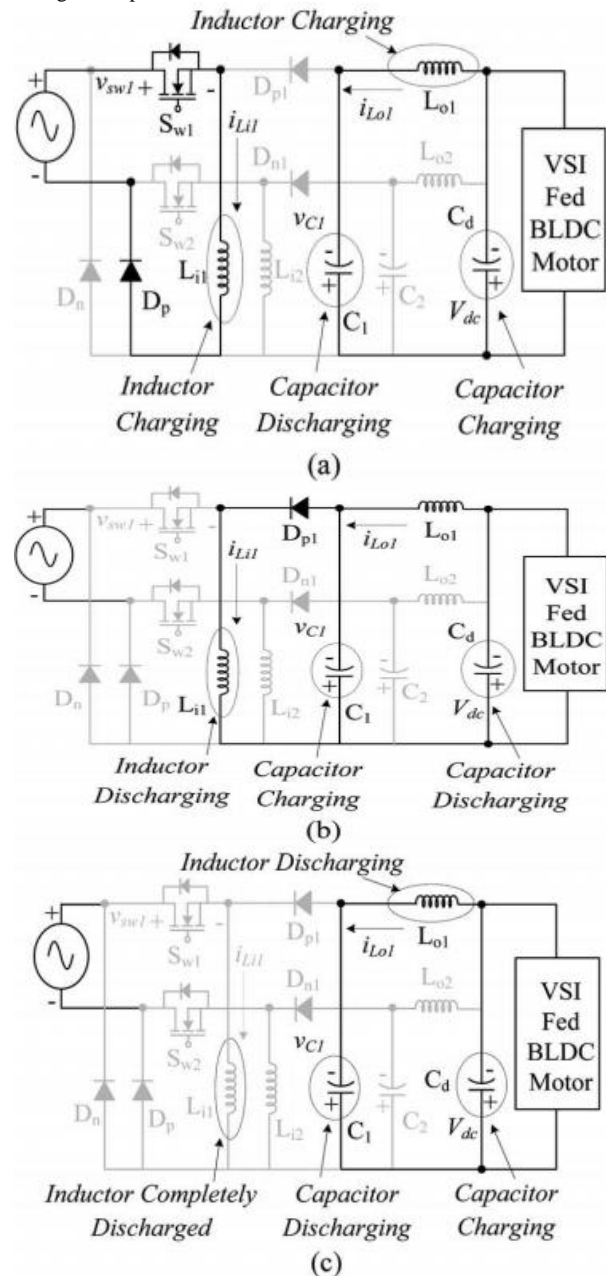

Fig. 2. Proposed PFC BL-Luo converter-fed BLDC motor drive.



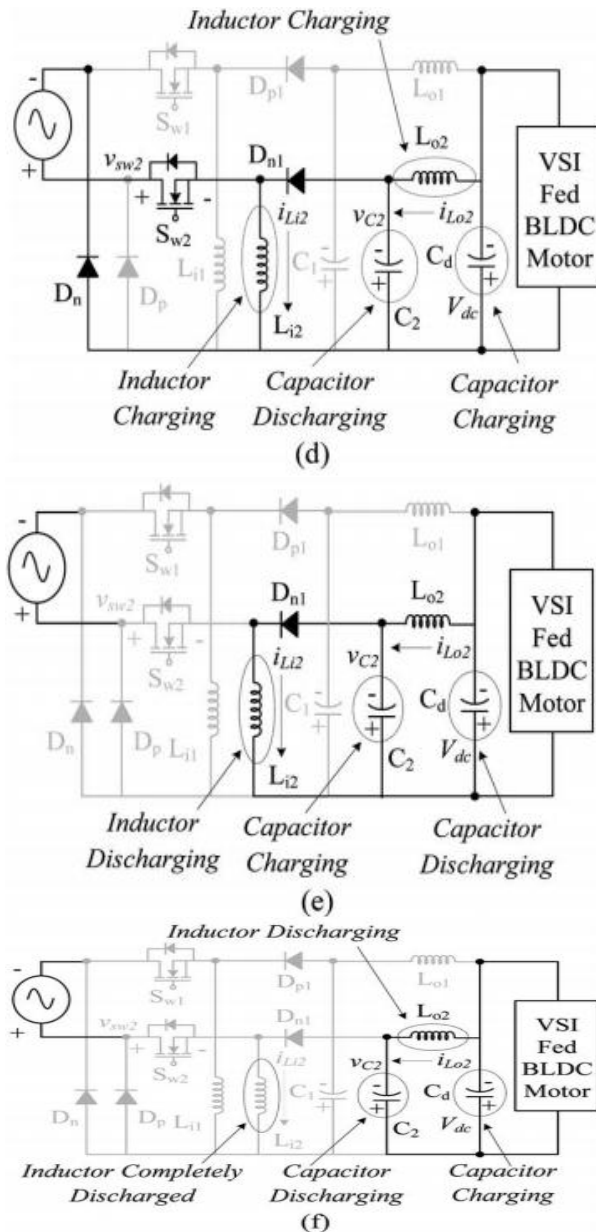

Fig. 3. Different modes of operation of the PFC BL-Luo converter during (a-c) positive and (d-f) negative half cycles of supply voltage. (a) Mode P-I. (b) Mode P-II. (c) Mode P-III. (d) Mode N-I. (e) Mode N-II. (f) Mode N-III.

B. Operation during Complete Switching Cycle

Fig. 4(b) shows the operation of the PFC BL-Luo converter during a complete switching period for a positive half cycle of supply voltage.

Mode P-I: As shown in Fig. 3(a), when switch Sw1 is turned on, the input side inductor (Li1) stores energy, depending upon the current (iLi) flowing through it and the inductor value (Li1). Moreover, the energy stored in the intermediate capacitor(C1) is transferred to the dc-link capacitor (Cd) and the outoutside inductor (Lio). Hence, the voltage across the intermediate capacitor (VC1) decreases, whereas the current in the output inductor (iLo1) and the dc-link voltage (Vdc) are increased as shown in Fig. 4(b).

Mode P-II: As shown in Fig. 3(b), when switch Sw1 is turned off, the input side inductor (Li1) transfers its energy to the intermediate capacitor (C1) via diode

Dp1. Hence, the current iLi1 decreases until it reaches zero, whereas the voltage across the intermediate capacitor (VC1) increases as shown in

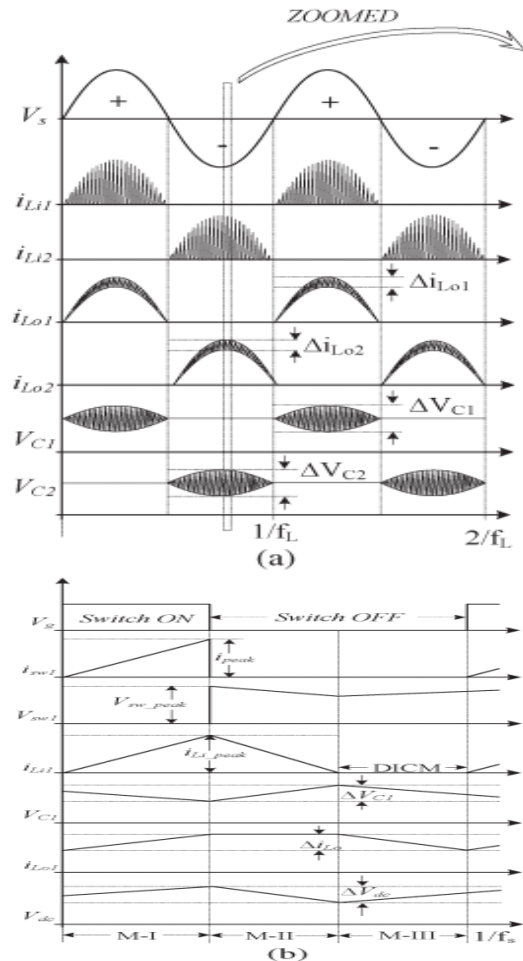

Fig. 4. Waveforms of BL-Luo converter during its operation for (a) complete line cycle and (b) complete switching cycle.

Fig. 4(b). The dc-link capacitor (Cd) provides the required energy to the load; hence, the dc-link voltage Vdc reduces in this mode of operation.

Mode P-III: As shown in Fig. 3(c), no energy is left in the input inductor (Li1), i.e., current iLi1 becomes zero and enters the discontinuous conduction mode of operation. The intermediate capacitor (C1) and output inductor (Lo1) are discharged; hence, current iLo1 and voltage VC1 are reduced, and dc-link voltage Vdc increases in this mode of operation as shown in Fig. 4(b). The operation is repeated when switch Sw1 is turned on again. In a similar way, for a negative half cycle of supply voltage, the inductor's Li2 and Lo2, diode Dn1, and intermediate capacitor C2 conduct to achieve a desired operation.

IV. CONTROL OF PFC BL-LUO CONVERTER-FED BLDC MOTOR DRIVE

The control of the PFC BL-Luo converter-fed BLDC motor drive is classified into two parts as follows.

A. Control of Front-End PFC Converter: Voltage Follower Approach

The control of the front-end PFC converter generates the PWM pulses for the PFC converter switches (Sw1 and Sw2) for dc-link voltage control with PFC

operation. A single voltage control loop (voltage follower approach) is utilized for the PFC BL-Luo converter operating in DICM. A reference dc-link voltage (V_{dc}^*) is generated as

$$V_{dc}^* = k_v \omega^* \tag{1}$$

Where k_v and ω^* are the motor's voltage constant and reference speed.

The reference dc-link voltage (V_{dc}^*) is compared with the sensed dc-link voltage (V_{dc}) to generate the voltage error signal (V_e) given as

$$V_e(k) = V_{dc}^*(k) - V_{dc}(k) \tag{2}$$

Where k represents the k th sampling instant.

This error-voltage signal (V_e) is given to the voltage proportional-integral (PI) controller to generate a controlled output voltage (V_{cc}) as

$$V_{cc}(k) = V_{cc}(k-1) + k_p \{V_e(k) - V_e(k-1)\} + k_i V_e(k) \tag{3}$$

Where k_p and k_i are the proportional and integral gains of the voltage PI controller. Finally, the output of the voltage controller is compared with a high frequency saw tooth signal (m_d) to generate the PWM pulses as

$$\left\{ \begin{array}{l} \text{if } m_d(t) < V_{cc}(t) \text{ then } S_{w1} = S_{w2} = \text{"ON"} \\ \text{if } m_d(t) \geq V_{cc}(t) \text{ then } S_{w1} = S_{w2} = \text{"OFF"} \end{array} \right\} \tag{4}$$

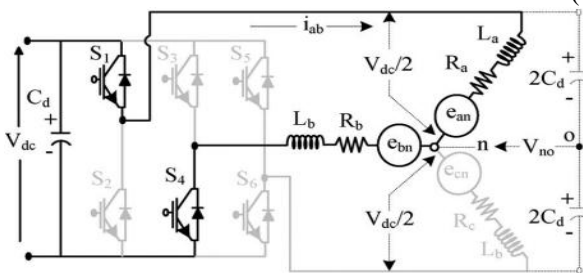

Fig. 5. VSI feeding a BLDC motor.

Table I

Switching States of VSI to Achieve Electronic Commutation of BLDC Motor

$\theta(^\circ)$	Hall Signals			Switching States					
	H_a	H_b	H_c	S_1	S_2	S_3	S_4	S_5	S_6
NA	0	0	0	0	0	0	0	0	0
0-60	0	0	1	1	0	0	0	0	1
60-120	0	1	0	0	1	1	0	0	0
120-180	0	1	1	0	0	1	0	0	1
180-240	1	0	0	0	0	0	1	1	0
240-300	1	0	1	1	0	0	1	0	0
300-360	1	1	0	0	1	0	0	1	0
NA	1	1	1	0	0	0	0	0	0

Where S_{w1} and S_{w2} represent the switching signals to the switches of the PFC converter. The modeling and stability issue of the proposed converter are discussed in the Appendix.

B. Control of BLDC Motor: Electronic Commutation

An electronic commutation of the BLDC motor includes the proper switching of VSI in such a way that a symmetrical dc current is drawn from the dc-link capacitor for 120° and placed symmetrically at the center of each phase. A rotor position on a span of 60° is required for electronic commutation, which is sensed

by Hall Effect position sensors. The conduction states of two switches (S_1 and S_4) are shown in Fig. 5. A line current i_{ab} is drawn from the dc-link capacitor, whose magnitude depends on the applied dc-link voltage (V_{dc}), back electromotive forces (EMFs) (e_{an} and e_{bn}), resistance (R_a and R_b), and self- and mutual inductances (L_a , L_b , and M) of the stator windings. Table I shows the governing switching states of the VSI feeding a BLDC motor based on the Hall Effect position signals (H_a - H_c).

V. INTRODUCTION TO FUZZY LOGIC CONTROLLER

L. A. Zadeh presented the first paper on fuzzy set theory in 1965. Since then, a new language was developed to describe the fuzzy properties of reality, which are very difficult and sometime even impossible to be described using conventional methods. Fuzzy set theory has been widely used in the control area with some application to dc-to-dc converter system. A simple fuzzy logic control is built up by a group of rules based on the human knowledge of system behavior. Matlab/Simulink simulation model is built to study the dynamic behavior of dc-to-dc converter and performance of proposed controllers. Furthermore, design of fuzzy logic controller can provide desirable both small signal and large signal dynamic performance at same time, which is not possible with linear control technique. Thus, fuzzy logic controller has been potential ability to improve the robustness of dc-to-dc converters. The basic scheme of a fuzzy logic controller is shown in Fig 5 and consists of four principal components such as: a fuzzification interface, which converts input data into suitable linguistic values; a knowledge base, which consists of a data base with the necessary linguistic definitions and the control rule set; a decision-making logic which, simulating a human decision process, infer the fuzzy control action from the knowledge of the control rules and linguistic variable definitions; a de-fuzzification interface which yields non fuzzy control action from an inferred fuzzy control action [10].

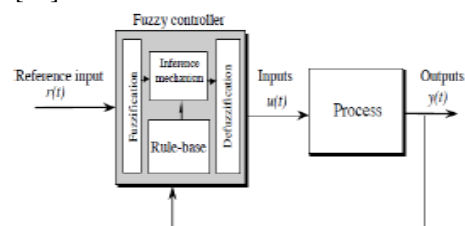

. General Structure of the fuzzy logic controller on closed-loop system The fuzzy control systems are based on expert knowledge that converts the human linguistic concepts into an automatic control strategy without any complicated mathematical model [10]. Simulation is performed in buck converter to verify the proposed fuzzy logic controllers.

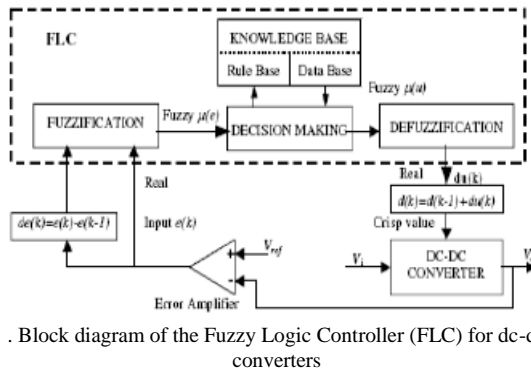

A. Fuzzy Logic Membership Functions:

The dc-dc converter is a nonlinear function of the duty cycle because of the small signal model and its control method was applied to the control of boost converters. Fuzzy controllers do not require an exact mathematical model. Instead, they are designed based on general knowledge of the plant. Fuzzy controllers are designed to adapt to varying operating points. Fuzzy Logic Controller is designed to control the output of boost dc-dc converter using Mamdani style fuzzy inference system. Two input variables, error (e) and change of error (de) are used in this fuzzy logic system. The single output variable (u) is duty cycle of PWM output.

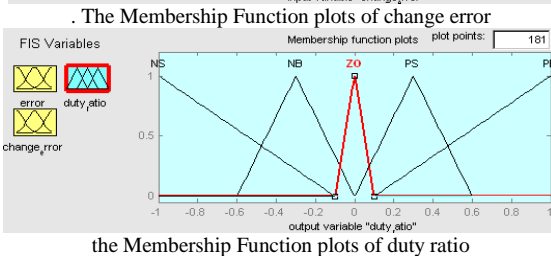
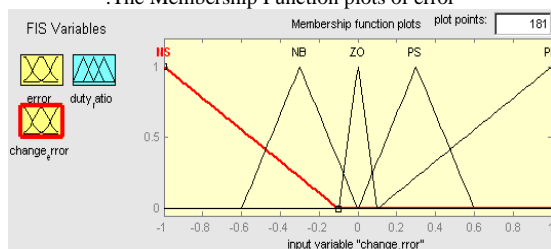
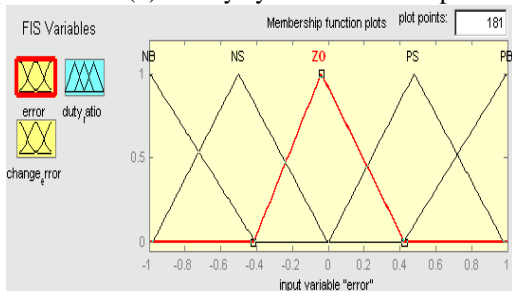

B. Fuzzy Logic Rules:

The objective of this dissertation is to control the output voltage of the boost converter. The error and change of error of the output voltage will be the inputs of fuzzy logic controller. These 2 inputs are divided into five groups; NB: Negative Big, NS: Negative Small, ZO: Zero Area, PS: Positive small and PB: Positive Big and

its parameter [10]. These fuzzy control rules for error and change of error can be referred in the table that is shown in Table II as per below:

Table II

Table rules for error and change of error

(de) \ (e)	NB	NS	ZO	PS	PB
NB	NB	NB	NB	NS	ZO
NS	NB	NB	NS	ZO	PS
ZO	NB	NS	ZO	PS	PB
PS	NS	ZO	PS	PB	PB
PB	ZO	PS	PB	PB	PB

V.MATLAB/SIMULATION RESULTS

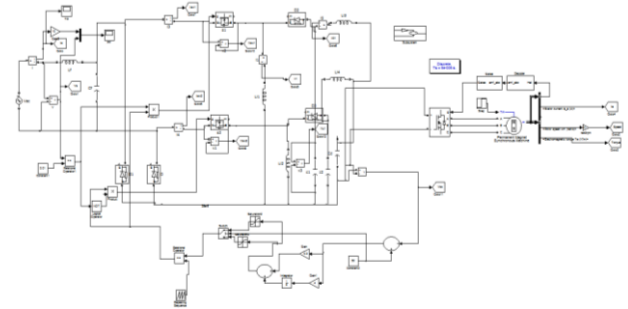

Fig.6. Matlab/Simulation model of bridge less Lou converter fed BLDC Motor.

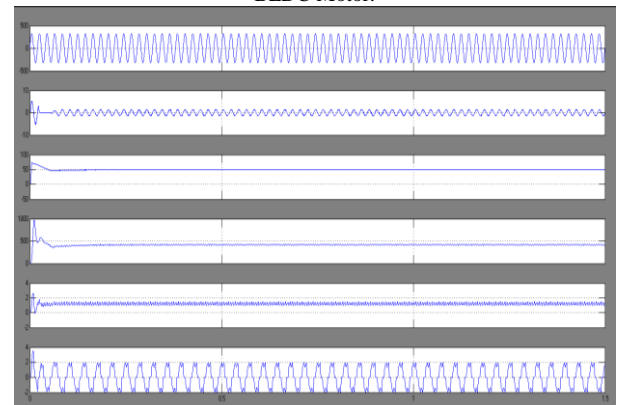

Fig.7. Test results of proposed BLDC motor drive At rated load torque on BLDC motor with Vdc = 50 V and Vs = 220 V.

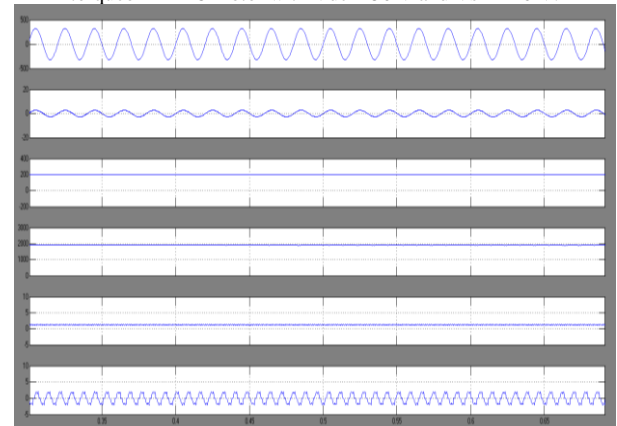

Fig.8. Test results of proposed BLDC motor drive At rated load torque on BLDC motor with Vdc = 200 V and Vs = 220 V.

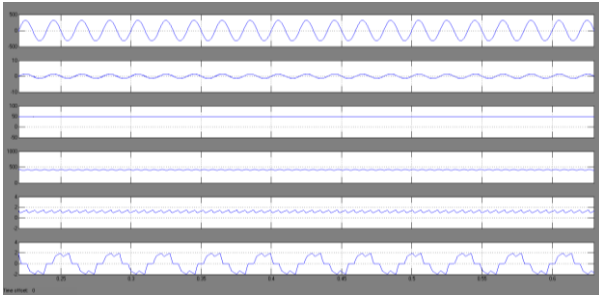

Fig.9. Test results of proposed BLDC motor drive showing dynamic performance during starting at 50 V.

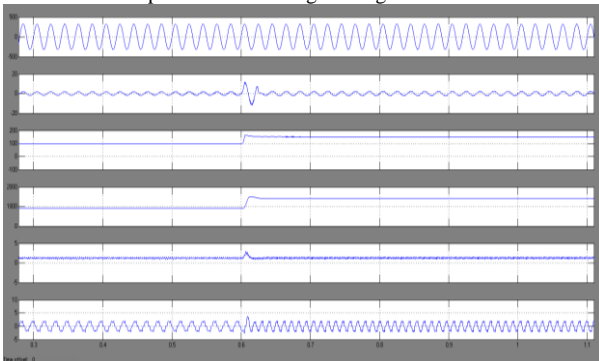

Fig.10. Test results of proposed BLDC motor drive showing dynamic performance during change in dc-link voltage from 100 to 150 V.

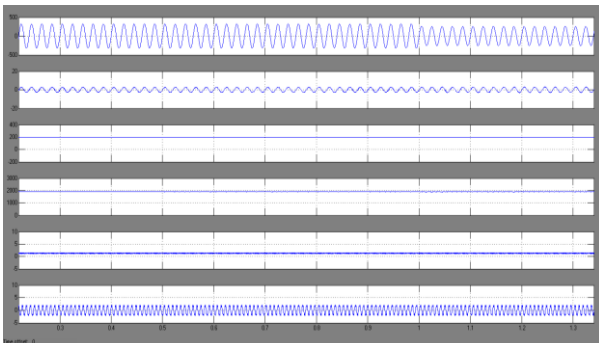

Fig.11. Test results of proposed BLDC motor drive showing dynamic performance of the during change in supply voltage from 250 to 180

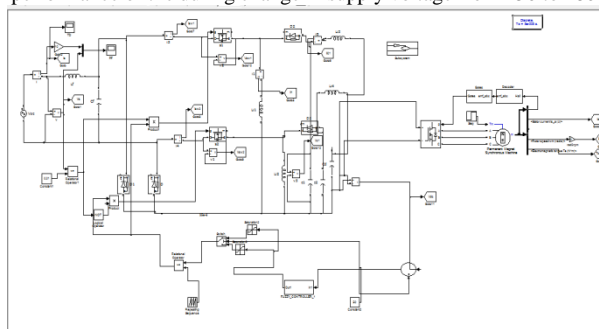

Fig 12 Matlab/Simulation model of bridge less Lou converter fed BLDC Motor with fuzzy logic controller

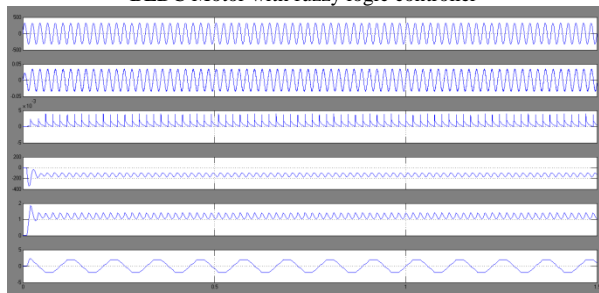

Fig 13 simulation wave form of output performance voltage current, dc voltage and speed torque

VI.CONCLUSION

A PFC BL-Lou converter-based VSI-fed BLDC motor drive has been proposed targeting low-power applications. A new method of speed control has been utilized by controlling the voltage at dc bus and operating the VSI at fundamental frequency for the electronic commutation of the BLDC motor for reducing the switching losses in VSI. The front-end BL Lou converter has been operated in DICM for achieving an inherent power factor correction at ac mains. Moreover, voltage and current stresses on the based PFC switch have been evaluated for determining the practical application of the proposed scheme. Finally, simulations of the proposed drive has been developed to validate the performance of the fuzzy logic controller is proposed BLDC motor drive under speed control with improved power quality at ac mains. The proposed scheme has shown satisfactory performance, and it is a recommended solution applicable to low-power BLDC motor drives.

REFERENCES

- [1] Bhim Singh, Fellow, IEEE, Vashist Bist, Student Member, IEEE, Amrish Chandra, Fellow, IEEE, and Kamal Al-Haddad, Fellow, IEEE "Power Factor Correction in Bridgeless-Luo Converter-Fed BLDC Motor Drive" IEEE TRANSACTIONS ON INDUSTRY APPLICATIONS, VOL. 51, NO. 2, MARCH/APRIL 2015
- [2] C. L. Xia, Permanent Magnet Brushless DC Motor Drives and Controls. Beijing, China: Wiley, 2012.
- [3] T. Kenjo and S. Nagamori, Permanent Magnet Brushless DC Motors. Oxford, U.K.: Clarendon, 1985.
- [4] R. Krishnan, Electric Motor Drives: Modeling, Analysis and Control. New Delhi, India: Pearson Education, 2001.
- [5] T. J. Sokira and W. Jaffe, Brushless DC Motors: Electronic Commutation and Control. Blue Ridge Summit, PA, USA: Tab Books, 1989.
- [6] H. A. Toliyat and S. Campbell, DSP-Based Electromechanical Motion Control. New York, NY, USA: CRC Press, 2004.
- [7] S. Singh and B. Singh, "A voltage-controlled PFC Cuk converter based PMBLDCM drive for air-conditioners," IEEE Trans. Ind. Appl., vol. 48, no. 2, pp. 832–838, Mar./Apr. 2012.
- [8] Limits for Harmonic Current Emissions (Equipment input current ≤ 16 A per phase), International Std. IEC 61000-3-2, 2000.
- [9] B. Singh et al., "A review of single-phase improved power quality acdc converters," IEEE Trans. Ind. Electron., vol. 50, no. 5, pp. 962–981, Oct. 2003.
- [10] B. Singh, S. Singh, A. Chandra, and K. Al-Haddad, "Comprehensive study of single-phase ac-dc power factor corrected converters with highfrequency isolation," IEEE Trans. Ind. Informat., vol. 7, no. 4, pp. 540–556, Nov. 2011.
- [11] S. B. Ozturk, O. Yang, and H. A. Toliyat, "Power factor correction of direct torque controlled brushless dc motor drive," in Conf. Rec. 42nd IEEE IAS Annu. Meeting, Sep. 23–27, 2007, pp. 297–304.
- [12] T. Y. Ho, M. S. Chen, L. H. Yang, and W. L. Lin, "The design of a high power factor brushless dc motor drive," in Int. Symp. Comput., Consum. Control, Jun. 4–6, 2012, pp. 345–348.
- [13] T. Gopalarathnam and H. A. Toliyat, "A new topology for unipolar brushless dc motor drive with high power factor," IEEE Trans. Power Electron., vol. 18, no. 6, pp. 1397–1404, Nov. 2003.



G.SUHASINI received B.Tech degree from St.Ann's college of Engineering and Technology(JNTUK) in the year 2009 and received M.Tech in the stream of Power Electronics at V.R.S and Y.R.N college of Engineering and

Technology(JNTUK) in the year 2013. Currently working as a Assistant Professor in Narsimha Reddy Engineering College for Three years. Her areas of interest are Applications of Power electronics in "Power Systems& Electrical machines".

Email: guthi.suhasini@gmail.com.



Yadam Nagendra received B.Tech degree from Kandula Obul Reddy memorial College of Engineering (JNTUA) in the year 2012 and received M.Tech in the stream of Power Electronics at

St.Martin's

Engineering college (JNTUH) in the year 2014. Currently working as a Assistant Professor in Narsimha Reddy Engineering college for two years. His current research interests include power electronics for photovoltaic (PV) applications and PV generation and monitoring, include multilevel converters, power converters for distributed energy resources.

Email: withnagendra@gmail.com



MAHESH BABU BONTHU received B.tech from Hyderabad Institute of Technology and Management in the year of 2014 and now pursuing M.Tech in the stream of Power Electronics at Narsimha

Reddy Engineering college.

Email: babumahesh149@gmail.com