

Power Flow Improvement in Transmission Line with Reduced DC Link Capacitor Using UPFC

*M.ASMITHA

**V.SREEPRIYA

*M.TECH student ,Dept of EEE, S.R Engineering College

*Assistant Professor, Dept of EEE , S.R Engineering College

Abstract:

This paper proposes a new real and reactive power coordination controller for a unified power flow controller (UPFC). The basic control for the UPFC is such that the series converter of the UPFC controls the transmission line real/reactive power flow and the shunt converter of the UPFC controls the UPFC bus voltage/shunt reactive power and the DC link capacitor voltage. In steady state, the real power demand of the series converter is supplied by the shunt converter of the UPFC. To avoid instability/loss of DC link capacitor voltage during transient conditions, a new real power coordination controller has been designed. The need for reactive power coordination controller for UPFC arises from the fact that excessive bus voltage (the bus to which the shunt converter is connected) excursions occur during reactive power transfers. A new reactive power coordination controller has been designed to limit excessive voltage excursions during

reactive power transfers. MATLAB/SIMULINK simulation results have been presented to show the improvement in the performance of the UPFC control with the proposed real power and reactive power co ordination controller.

1. Introduction

UPFC is the most comprehensive multivariable flexible ac transmission system (FACTS) controller. Simultaneous control of multiple power system variables with UPFC possesses enormous difficulties. In addition, the complexity of the UPFC control increases due to the fact that the controlled and the control variables interact with each other UPFC which consists of a series and a shunt converter connected by a common dc link capacitor can simultaneously perform the function of transmission line real/reactive power flow control in addition to UPFC bus voltage/shunt reactive power control [1]. The shunt converter of the UPFC controls the UPFC bus voltage/shunt reactive power

and the dc link capacitor voltage. The series converter of the UPFC controls the transmission line real/reactive power flows by injecting a series voltage of adjustable magnitude and phase angle. The interaction between the series injected voltage and the transmission line current leads to real and reactive power exchange between the series converter and the power system. Under steady state conditions, the real power demand of the series converter is supplied by the shunt converter. But during transient conditions, the series converter real power demand is supplied by the dc link capacitor. If the information regarding the series converter real demand is not conveyed to the shunt converter control system, it could lead to collapse of the dc link capacitor voltage and subsequent removal of UPFC from operation

In contrast to real power coordination between the series and shunt converter control system, the control of transmission line reactive power flow leads to excessive voltage excursions of the UPFC bus voltage during reactive power transfers. This is due to the fact that any change in transmission line reactive power flow achieved by adjusting the magnitude/phase angle of the series injected voltage of the UPFC is actually supplied by the shunt converter. The excessive voltage excursions of the

UPFC bus voltage is due to absence of reactive power coordination between the series and the shunt converter control system. This aspect of UPFC control has also not been investigated [2]–[15]. A new reactive power coordination controller between the series and the shunt converter control system has been designed to reduce UPFC bus voltage excursions during reactive power transfers. UPFC control system that includes the real and reactive power coordination controller has been designed and its performance evaluated. Sections II and III describes the basic control strategy and control system for a UPFC. Section IV provides the details of the real and reactive power coordination controller.

2. Control Strategy for UPFC

A. Shunt Converter Control Strategy

The shunt converter of the UPFC controls the UPFC bus voltage/shunt reactive power and the dc link capacitor voltage. In this case, the shunt converter voltage is decomposed into two components. One component is in-phase and the other in quadrature with the UPFC bus voltage. Decoupled control system has been employed to achieve simultaneous control of the UPFC bus voltage and the dc link capacitor voltage.

B. Series Converter Control Strategy

The series converter of the UPFC provides simultaneous control of real and reactive power flow in the transmission line. To do so, the series converter injected voltage is decomposed into two components. One component of the series injected voltage is in quadrature and the other in-phase with the UPFC bus voltage. The quadrature injected component controls the transmission line real power flow. This strategy is similar to that of a phase shifter. The in-phase component controls the transmission line reactive power flow. This strategy is similar to that of a tap changer.

C. Shunt Converter Control System

The D-axis control system controls the dc link capacitor voltage and the Q-axis control system controls the UPFC bus voltage /shunt reactive power. The details of the de-coupled control system design can be found in [16], [17]. The de-coupled control system has been de-signed based on linear control system techniques and it consists of an outer loop control system that sets the reference for the inner control system loop. The inner control system loop tracks the reference.

D. Series Converter Control Parameters

1) Transmission line real power flow controller parameters

$K_p=1$; $K_i=4$;

E. Series Converter Control System

The transmission line real power flow is controlled by injecting a component of the series voltage in quadrature with the UPFC bus voltage. The transmission line reactive power is controlled by modulating the transmission line side bus voltage reference. The transmission line side bus voltage is controlled by injecting a component of the series voltage in-phase with the UPFC bus voltage. The parameters of the PI controllers Transmission line reactive power flow controller parameters:

a) Outer loop controller $K_p= -0.1$; $K_i= -1$;

b) Inner loop controller $K_p= 0.15$; $K_i= 25$;

F. Real Power Coordination Controller

To understand the design of a real power coordination controller for a UPFC, consider a UPFC connected to a transmission line as shown in Fig. 1. The interaction between the series injected voltage and the transmission line current leads to exchange of real power between the series converter and the transmission line. The real power demand of the series converter causes the dc link capacitor voltage to either increase or decrease depending on the direction of the real power flow from the series converter. This decrease/increase in dc link capacitor voltage is sensed by the shunt converter controller that controls the dc link capacitor voltage and acts to increase/decrease the shunt converter real power flow to bring the

dc link capacitor voltage back to its scheduled value. Alternatively, the real power demand of the series converter is recognized by the shunt converter controller only by the decrease/increase of the dc link capacitor voltage. Thus, the shunt and the series converter operation are in a way separated from each other. To provide for proper coordination between the shunt and the series converter control system, a feedback from the series converter is provided to the shunt converter control system. The feedback signal used is the real power demand of the series converter. The real power demand of the series converter is converted into an equivalent D-axis current for the shunt converter. By doing so, the shunt converter responds immediately to a change in its D-axis current and supplies the necessary series converter real power demand. The equivalent D-axis current is an additional input to the D-axis shunt converter control system, the relationship between the series converter real power demand and the shunt converter D-axis current to exchange of real power between the series converter and the transmission line. The real power demand of the series converter causes the dc link capacitor voltage to either increase or decrease Fig. 2.

depending on the direction of the real power flow from the series converter. This decrease/increase in dc link capacitor voltage is sensed by the shunt converter controller that controls the dc link capacitor voltage and acts to increase/decrease the shunt converter real power flow to bring the dc link capacitor voltage back to its scheduled value. Alternatively, the real power demand of the series converter is recognized by the shunt converter controller only by the decrease/increase of the dc link capacitor voltage. Thus, the shunt and the series converter operation are in a way separated from each other. To provide for proper coordination between the shunt and the series converter control system, a feedback from the series converter is provided to the shunt converter control system. The feedback signal used is the real power demand of the series converter. The real power demand of the series converter is converted into an equivalent D-axis current for the shunt converter. By doing so, the shunt converter responds immediately to a change in its D-axis current and supplies the necessary series converter real power demand. The equivalent D-axis current is an additional input to the D-axis shunt converter control system as shown in

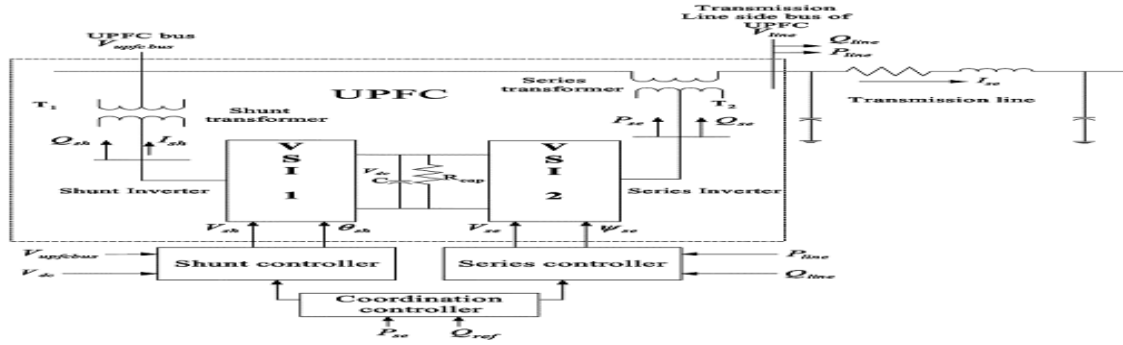

Fig.1 UPFC connected to a transmission line

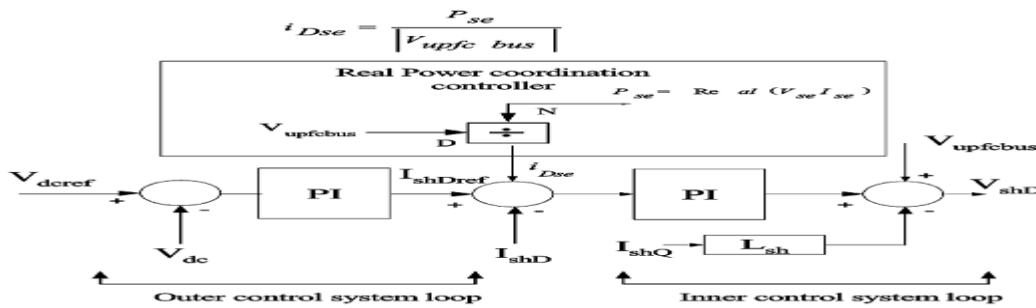

Fig.2. D-axis shunt converter control system with real power coordination controller.

G. Effect of Real Power Coordination Controller

To study the efficacy of the real power coordination controller, a power system has been considered with the machines are equipped with static exciters and PSS. The generator, exciter, PSS, synchronous motor load, and UPFC parameters are given in Appendix B [21]. The total load in the power system is 700 MW. The load has been modeled as a synchronous motor. Generator G2 supplies 500 MW of power and the rest of the power is generated by G1. Generator G1 also supplies the system losses. The steady-state power flow in the 345 kV transmission line is 400 MW. The 230 kV transmission line carries 100 MW of power. The UPFC is located at the center of a 160-km 345-kV line. The shunt converter of the UPFC controls the dc link capacitor voltage and the shunt converter reactive power. The series converter of the UPFC controls the real power flow in the transmission line at 400 MW and the reactive power flow at 100 MVAR. A three-phase fault is conducted at 12 s for 50 ms at bus-B with no change in network configuration. The three-phase fault causes the real power to be generated by the UPFC leading to reduction in dc link capacitor voltage. The dc link capacitor voltage drops to about 20 kV.

MODELLING OF UPFC

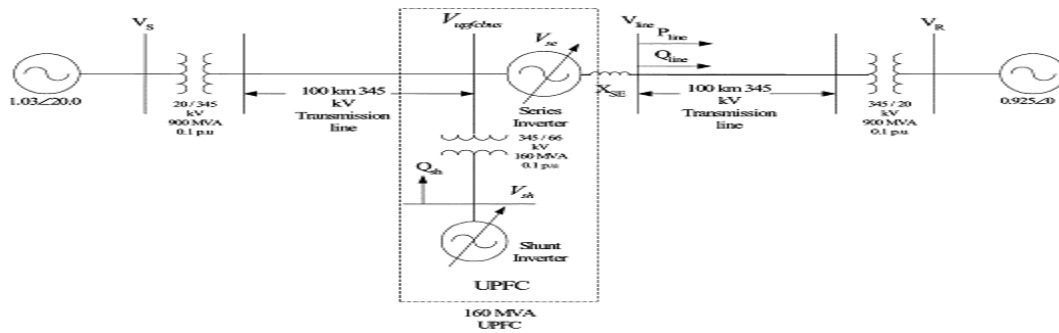

Fig. 3 Power System with UPFC

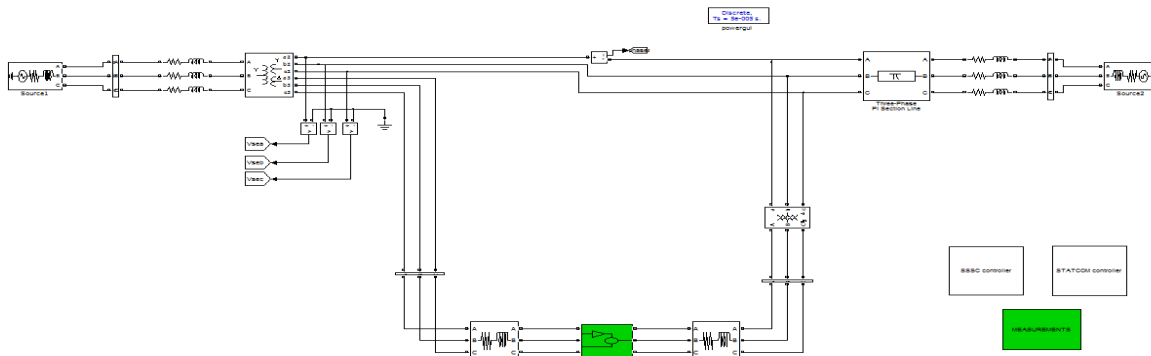

Fig.4 Simulink model for UPFC

SIMULATION RESULTS

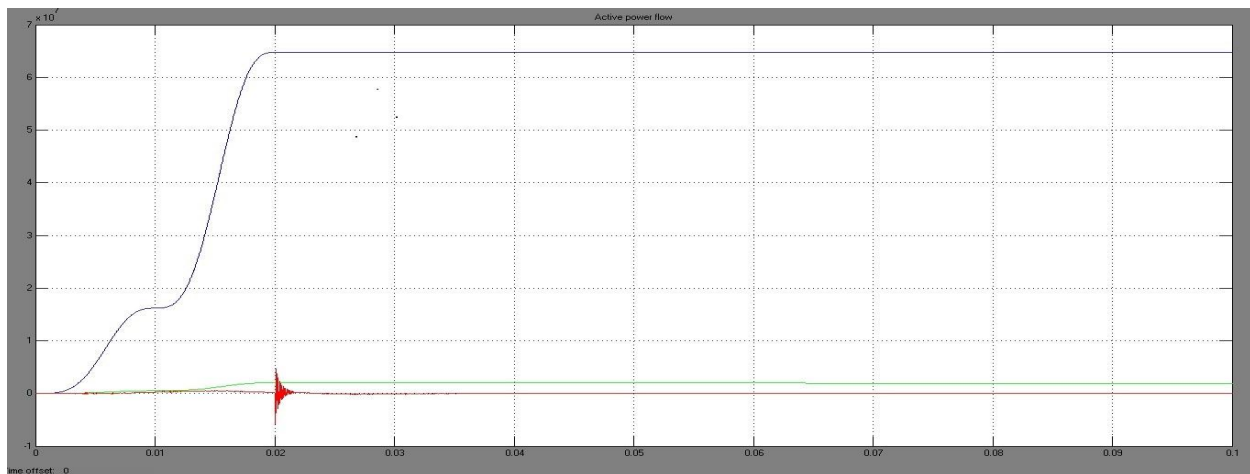

Fig 5. With UPFC active power flow in transmission line

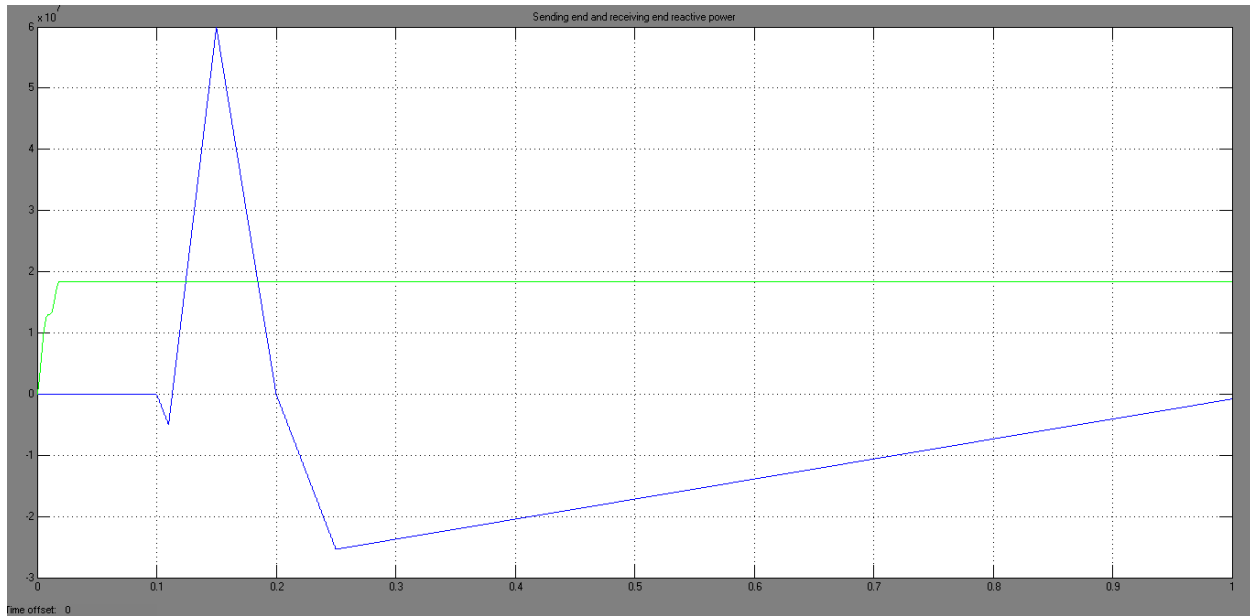

Fig 6. With UPFC reactive power flow in transmission line

SIMULINK MODEL FOR WITHOUT UPFC

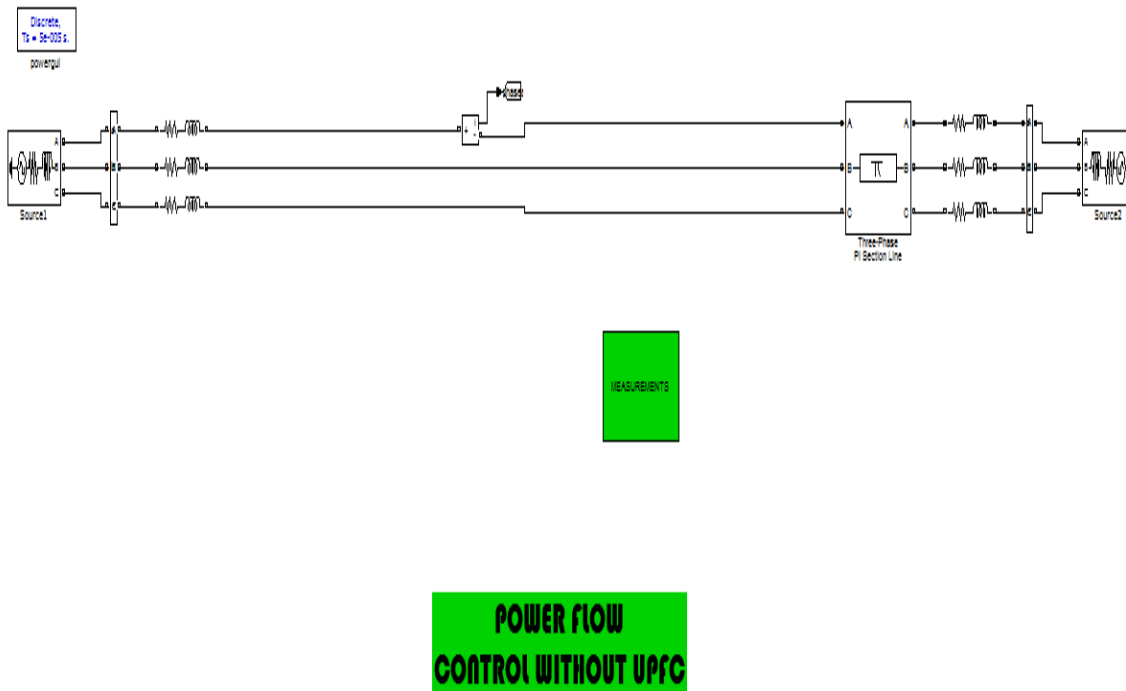

Fig 7. Power System without UPFC

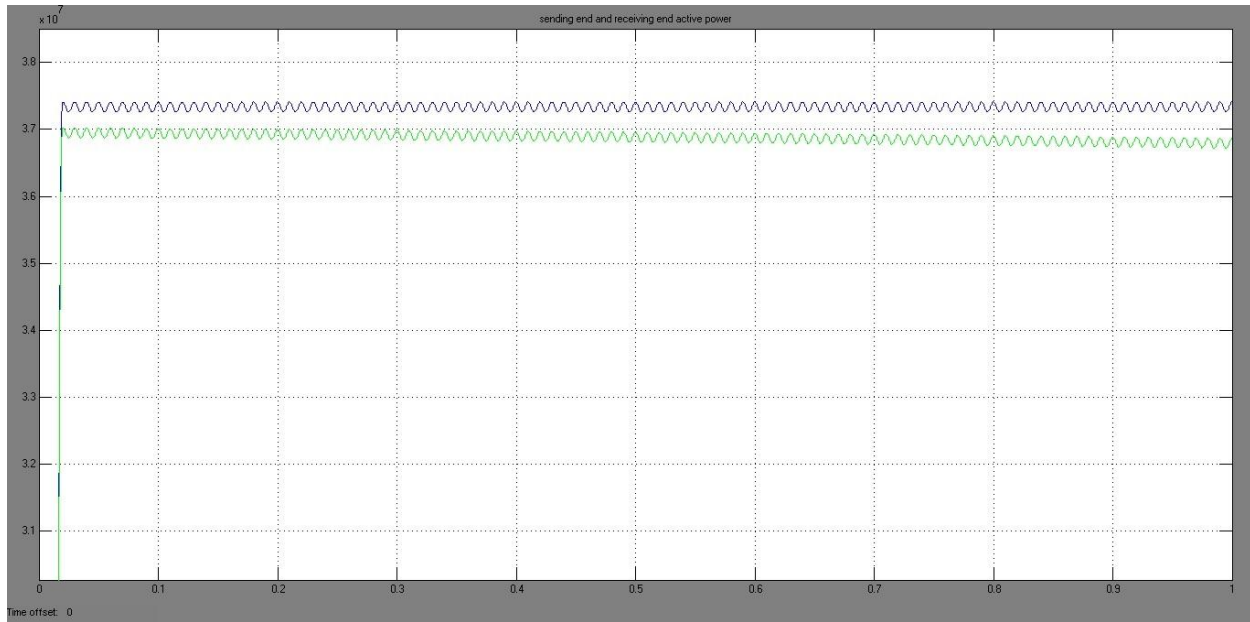

Fig 8. Active power without UPFC in transmission line

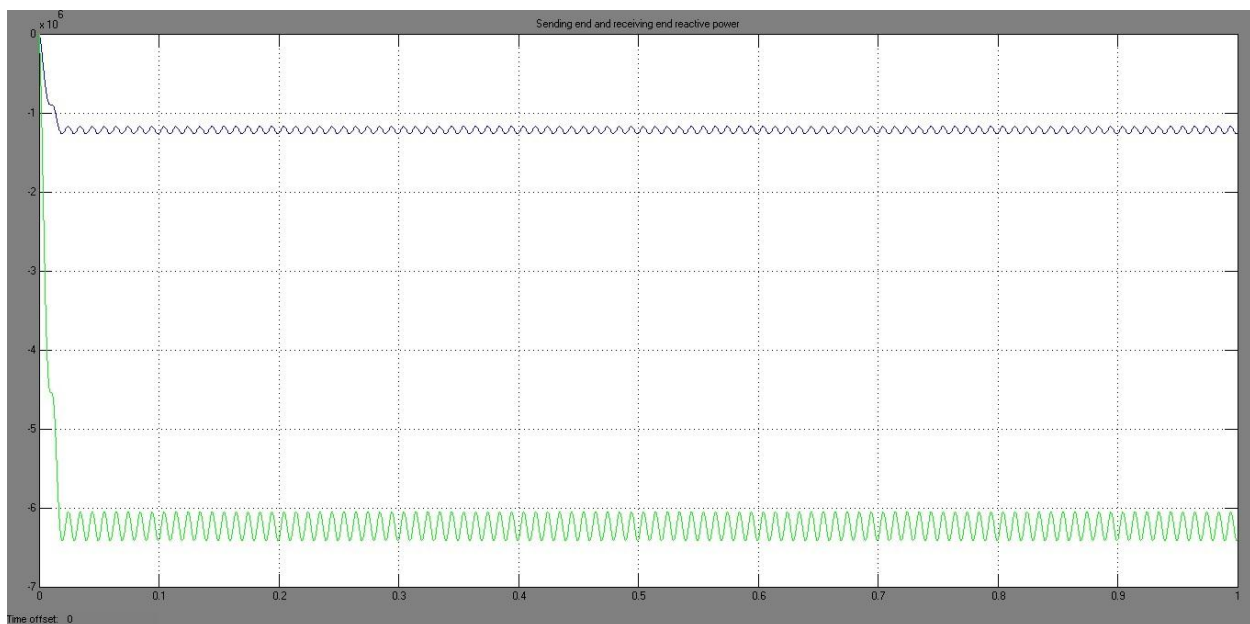

Fig 9. Reactive power flow without UPFC in transmission line

5. Conclusion

This paper has presented a new real and reactive power co-ordination controller for a UPFC. The basic control strategy is such that the shunt converter of the UPFC controls the UPFC bus voltage/shunt reactive power and the dc link capacitor voltage. The series converter controls the transmission line real and reactive power flow. The contributions of this work can be

summarized as follows. Two important coordination problems have been addressed in this paper related to UPFC control. One, the problem of real power coordination between the series and the shunt converter control system. Second, the problem of excessive UPFC bus voltage excursions during reactive power transfers requiring reactive power coordination. Inclusion of the real power coordination controller in the UPFC control system avoids excessive dc link capacitor voltage excursions and improves its recovery during transient conditions. PSCAD-EMTDC simulations have been conducted to verify the improvement in dc link voltage excursions during transient conditions. Inclusion of reactive power coordination controller helps in significantly reducing UPFC bus voltage excursions during re-active power transfers. The effect on transmission line reactive power flow is minimal. MATLAB simulations have shown the improvement in power oscillation damping with UPFC.

References

- [1] L. Gyugyi, C. D. Schauder, S. L. Williams, T. R. Reitman, D. R. Torgerson, and A. Edris, "The unified power flow controller: A new approach to power transmission control," IEEE Trans. Power Delivery, vol. 10, pp.1085–1097, Apr. 1995.
- [2] C. D. Schauder, L. Gyugyi, M. R. Lund, D. M. Hamai, T. R. Rietman, D. R. Torgerson, and A. Edris, "Operation of the unified power flow controller (UPFC) under practical constraints," IEEE Trans. Power Delivery, vol. 13, pp. 630–636, Apr. 1998.
- [3] K. K. Sen and E. J. Stacey, "UPFC-Unified Power flow controller: Theory, modeling, and applications," IEEE Trans. Power Delivery, vol. 13, pp. 1453–1460, Oct. 1999.
- [4] B. A. Renz, A. S. Mehraben, C. Schauder, E. Stacey, L. Kovalsky, L. Gyugyi, and A. Edris, "AEP unified power flow controller performance," IEEE Trans. Power Delivery, vol. 14, pp. 1374–1381, Oct. 1999.
- [5] P. K. Dash, S. Mishra, and G. Panda, "A radial basis function neural network controller for UPFC," IEEE Trans. Power Syst., vol. 15, pp. 1293–1299, Nov. 2000.
- [6] "Damping multimodal power system oscillation using a hybrid fuzzy controller for series connected FACTS devices," IEEE Trans. Power Syst, vol. 15, pp. 1360– 1366, Nov. 2000.

AUTHOR 1:-

* M.ASMITHA completed her B tech in Vaagdevi College Of Engineering in 2012 and pursuing M-Tech in S.R Engineering College

AUTHOR 2:-

*V.SREEPRIYA is working as Assistant Professor in Dept of EEE, S.R Engineering College