

Grid Voltage Regulation by Using PV Based Dual Topology of the Unified Power Quality Conditioner (iUPQC)

Name: G Swathi
R.No: 133A1D8214
Qualification: M.Tech EEE
College Global college of engineering and technology

Guide Name: M L Dwarakanad
Qualification: M.E, M.Tech
Designation: Associate professor and Head of the Department

ABSTRACT:

This paper introduces an improved controller for Interline Unified Power Quality Conditioner (iUPQC), extending from its conventional performance of load voltage regulation to grid voltage regulation also. The modified iUPQC can act as a Static Synchronous Compensator (STATCOM) on the grid side and as ordinary iUPQC at load part. The modified iUPQC approach has a Photovoltaic (PV) array alternatively of the dc link capacitor. The whole system was simulated in MATLAB/SIMULINK. The simulation results are proved to confirm the brand new performance of the gear.

KEY WORDS: iUPQC, power quality STATCOM, THD, UPQC.

INTRODUCTION:

In these days's power approach scenario, many problems can occur because of the terrible performance of the furnished power. The drastic increase within the usage of the energy digital devices has precipitated this

exceptional power quality disorders. On the other hand these energy digital masses as a rule requires an best sinusoidal deliver for his or her smooth functioning. Many devices that can mitigate this power quality issues has been invented over years. Essentially the most up to date tendencies in reducing the power quality problems are the utilization of the multitasking instruments that may compensate a number of energy high-quality problems simultaneously. Such most efficient device is the Unified power first-class Conditioner (UPQC), which used to be first presented by using Hirofumi Akagi in 1995 [1].UPQCs are categorized into one of a kind categories. Interline UPQC (iUPQC) or dual UPQC is without doubt one of the major one among them [2].Mostly, the shunt converter of the UPQC behaves as controlled present supply that compensates the load current likewise the series active filter behaves as controlled voltage source to compensate the voltage imperfections. In the

dual configuration of UPQC, known as Interline Unified energy fine Conditioner (iUPQC) the shunt energetic filter acts as a sinusoidal voltage supply and sequence converter as sinusoidal current source. There are a few benefits for the iUPQC over the traditional UPQC, i.e. The utilizing the fundamental confident sequence accessories of the current and voltage references for the sequence and shunt compensators, where as in conventional UPQC the nonsinusoidal compensating voltages and currents are used [3]. At reward, Static Synchronous Compensators (STATCOM) are generally used for voltage regulation [4]. UPQCs and iUPQCs are employed for more exact purposes. A widespread variety of applicability of iUPQC can be reached in smart grids and grid-tied microgrids if another performance of STATCOM will also be combined into traditional iUPQC. This outcome in reduced fee of total process. A Photovoltaic (PV) array can be modelled as an alternative for the dc hyperlink of iUPQC process.

UNIFIED POWER QUALITY CONDITIONER

The provision of both DSTATCOM and DVR can control the power quality of the source current and the load bus voltage. In addition, if the DVR and STATCOM are

connected on the DC side, the DC bus voltage can be regulated by the shunt connected DSTATCOM while the DVR supplies the required energy to the load in case of the transient disturbances in source voltage. The configuration of such a device (termed as Unified Power Quality Conditioner (UPQC)) is shown in Fig. 14.15. This is a versatile device similar to a UPFC. However, the control objectives of a UPQC are quite different from that of a UPFC.

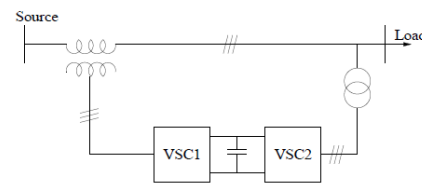

CONTROL OBJECTIVES OF UPQC

The shunt connected converter has the following control objectives

1. To balance the source currents by injecting negative and zero sequence components required by the load
2. The compensate for the harmonics in the load current by injecting the required harmonic currents
3. To control the power factor by injecting the required reactive current (at fundamental frequency)
4. To regulate the DC bus voltage.

The series connected converter has the following control objective. To balance the

voltages at the load bus by injecting negative and zero sequence voltages to compensate for those present in the source.

2. To isolate the load bus from harmonics present in the source voltages, by injecting the harmonic voltages

3. To regulate the magnitude of the load bus voltage by injecting the required active and reactive components (at fundamental frequency) depending on the power factor on the source side

4. To control the power factor at the input port of the UPQC (where the source is connected. Note that the power factor at the output port of the UPQC (connected to the load) is controlled by the shunt converter.

Operation of UPQC

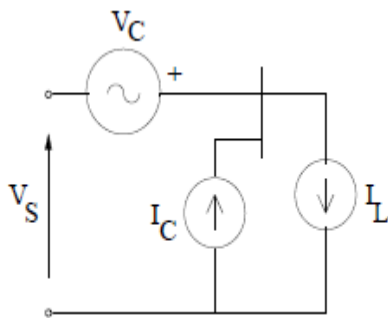

The operation of a UPQC can be explained from the analysis of the idealized equivalent circuit shown in Fig. 14.16. Here, the series converter is represented by a voltage source VC and the shunt converter is represented by a current source IC. Note that all the currents and voltages are 3 dimensional vectors with phase coordinates.

Unlike in the case of a UPFC (discussed in chapter 8), the voltages and currents may contain negative and zero sequence components in addition to harmonics. Neglecting losses in the converters, we get the relation

$$\langle V_L, I_C \rangle + \langle V_C, I_S \rangle = 0$$

where X,Y denote the inner product of two vectors, defined by

$$\langle X, Y \rangle = \frac{1}{T} \int_0^T X^t(\tau)Y(\tau)d\tau.$$

Let the load current IL and the source voltage VS be decomposed into two Components given by

$$I_L = I_L^{1p} + I_L^r$$

$$V_S = V_S^{1p} + V_S^r$$

Where I_p L contains only positive sequence, fundamental frequency components. Similar comments apply to V_{1p} S . IrL and V_r S contain rest of the load current and the source voltage including harmonics. I_pL is not unique and depends on the power factor at the load bus. However, the following relation applies for I_p L .

$$P_L = \langle V_L, I_L \rangle = \langle V_L, I_L^{1p} \rangle$$

This implies that hIrL ; VLi = 0. Thus, the fundamental frequency, positive sequence component in IrL does not

contribute to the active power in the load. To meet the control objectives, the desired load voltages and source currents must contain only positive sequence, fundamental frequency components and

$$P_L = |V_L^* I_S^*| \cos \phi_l = |V_S^{1p} I_S^*| \cos \phi_s$$

where $V \propto L$ and $I \propto S$ are the reference quantities for the load bus voltage and the source current respectively. ϕ_l is the power factor angle at the load bus while ϕ_s is the power factor angle at the source bus (input port of UPQC). Note that $V \propto L(t)$ and $I \propto S(t)$ are sinusoidal and balanced. If the reference current ($I \propto C$) of the shunt converter and the reference voltage ($V \propto C$) of the series converter are chosen as

$$I_C^* = I_L^*, \quad V_C^* = -V_S^r + V_C^{1p}$$

with the constraint

$$\langle V_C^{1p}, I_S^* \rangle = 0$$

we have,

$$I_S^* = I_L^{1p}, \quad V_L^* = V_S^{1p} + V_C^{1p}$$

Note that the constraint (14.30) implies that V_C^{1p} is the reactive voltage in quadrature with the desired source current, $I \propto S$. It is easy to derive that $\langle V_C^*, I_S^* \rangle = 0 = \langle I_C^*, V_L^* \rangle$. The above equation shows that for the operating conditions assumed, a UPQC can be viewed as a inaction of a DVR and a STATCOM

with no active power flow through the DC link. However, if the magnitude of $V \propto L$ is to be controlled, it may not be feasible to achieve this by injecting only reactive voltage. The situation gets complicated if V_C^{1p} is not constant, but changes due to system disturbances or fault. To ensure the regulation of the load bus voltage it may be necessary to inject variable active voltage (in phase with the source current). If we express

$$V_C = V_C^* + \Delta V_C, I_C = I_C^* + \Delta I_C$$

$$I_S = I_S^* - \Delta I_C, V_L = V_S^{1p} + V_C^{1p} + \Delta V_C$$

$$\langle I_S, \Delta V_C \rangle + \langle V_L, \Delta I_C \rangle = 0$$

In deriving the above, we assume that

$$\langle I_S, V_C^* \rangle = 0 = \langle V_L, I_C^* \rangle$$

This implies that both ϕVC and ϕIC are perturbations involving positive sequence, fundamental frequency quantities (say, resulting from symmetric voltage sags). the power balance on the DC side of the shunt and series converter. The perturbation in VC is initiated to ensure that

$$|V_C^* + \Delta V_C + V_S| = |V_L| = \text{constant.}$$

Thus, the objective of the voltage regulation at the load bus may require exchange of power between the shunt and series converters.

iUPQC

In an iUPQC the series APF acts as a controlled sinusoidal current supply and the shunt APF acts as a controlled sinusoidal voltage source as shown in Fig.2. The shunt energetic filter offers negligible impedance to the harmonic current, even as the series energetic filter offers an infinite worth. Thus the harmonic present injected through the nonlinear load flows by way of the shunt active filter [6]. The boundaries of traditional UPQC can be overcome by the iUPQC, i.e. In conventional UPQC, whenever the controller has to calculate the compensating voltage and current, for this reason the requirement of processing as well as synthesizing more than one frequency indicators will make the controller design more intricate and has larger switching losses in the converters. The fundamental change between the UPQC and iUPQC is the changes in the shunt and series supply type

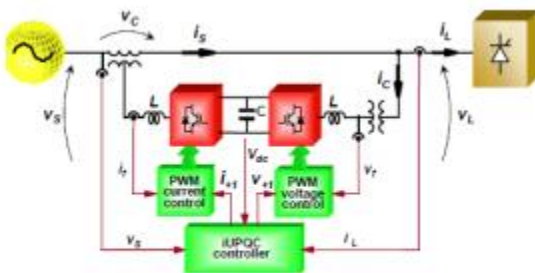
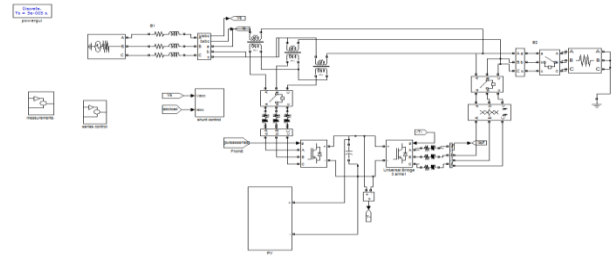
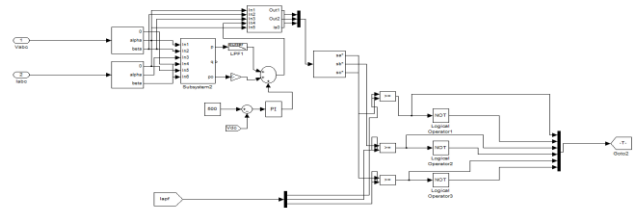

Fig.2. Structure of iUPQC



SIMULATION FILE

Control system



Results:

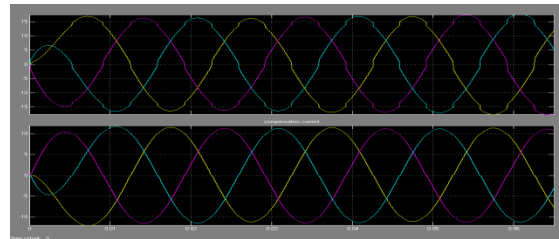

Fig: Load Current

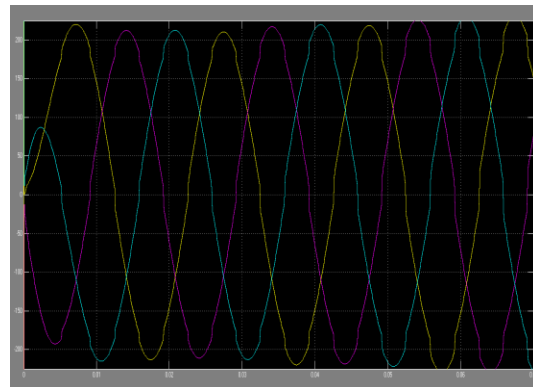

Fig: Vabc

CONCLUSION

when you consider that the usage of vigour electronic devices is growing daily, it is

extremely rough to keep the power high-quality on the appropriate limit. The UPQC and iUPQC is regarded as one of the most most state-of-the-art solutions to maintain vigor exceptional. It'll be extra important if one more performance of STATCOM for grid voltage regulation can be included in the iUPQC. This paper investigated the expanded controller performance of iUPQC to prove extra grid voltage regulation as STATCOM. A PV array is additionally modelled instead for the DC hyperlink capacitor. The simulation effects proves that the elevated iUPQC controller regulates the voltage both at load as good as at the source part. The THD analysis demonstrates that THD values of the extended iUPQC system diminished to a negligibly small price. The increased iUPQC controller was efficaciously realized by way of simulation. This will also be understood more competently by way of practical implementation also.

REFERENCES

- [1] H. Akagi, Edson Hirokazu Wantanbe and Mauricio Aredes -Instantaneous Power Theory and Applications To Power Conditionong, IEEE Press 2007.
- [2] V. Khadkikar -Enhancing electric power quality using UPQC: A comprehensive overview,IEEE Trans. Power Electron., vol. 27, no. 5, pp. 2284– 2297, May 2012.
- [3] M. Aredes and R. M. Fernandes -A dual topology of unified power quality conditioner: The iUPQC,in Proc. EPE Conf. Appl., 2009, pp. 1–10.
- [4] L. G. B. Rolim -Custom power interfaces for renewable energy sources, in Proc. IEEE ISIE, 2007, pp. 2673–2678 .
- [5] Meemakshi Bhardwaj and Akhil Gupta - Design and Implementation of UPQC to Solve Power Quality Problems, International Journal of Engineering and Technical Research (IJETR),vol.02.Issue.10.Oct 2014.
- [6] B. W. Franca and M. Aredes -Comparisons between the UPQC and its dual topology (iUPQC) in dynamic response and steady-state, in Proc.37th IEEE IECON, 2011, pp. 1232–1237.
- [7] Bruno W.Franca, ,Leonardo F.da.Silva M. Aredes and Mauricio Aredes -An Improved iUPQC Controller to Provide Additional GridVoltage Regulation as a STATCOM,IEEE Trans. Industrial Electronics., vol.62, no. 3, pp. 0278-0046, March 2015.
- [8] Sonal panwar and R.P. Saini –Development and Simulation of Solar Photovoltaic model using Matlab/simulink and its parameter extraction,presentedattheInternational Conference on Computing and Control Engineering (ICCCE), April 12 &13, 2012.