

# A Novel Three-Phase to Five-Phase Transformation Using a Special Transformer Connection

<sup>1</sup> Mr. Polipaka Venkateswarlu,  
[shiningvenky@gmail.com](mailto:shiningvenky@gmail.com)

*N.B.K.R. Institute of Science and Technology,  
S.P.S.R Nellore, Andhra Pradesh State, India*

<sup>2</sup>N. Usha, [(Ph.D.)]  
Assistant Professor, [vushareddy@gmail.com](mailto:vushareddy@gmail.com)

## Abstract:

*In today's electrical scenario due to ever increasing demand of more power it is necessary to supply it at a certain voltage level economically, which restricts it to a certain value. Moreover there are other limitations on utilization side as well. The solution for this is use of multiphase systems. Nowadays multiphase systems are being thought of as a solution for the problem and research in this field is picking up pace. There is a need to obtain multiphase supply from the available three phase supply due to its inherent advantages. PWM Technique is most suitable for employing two-drive systems with variable frequency which is more complicated. Hence Special Transformer Connection method is used in applications requiring fixed voltage and fixed frequency supply. This model can be simulated by using 'SIM POWERSYSTEMS' block sets of MATLAB or SIMULINK Software...*

## Keywords

*Five-phase, Multi-winding Transformer, Special Transformer connection, turns ratio, Five phase Induction Motor model.*

## 1. Introduction

The applicability of multiphase systems is explored in electric power generation, transmission, and utilization. The research on six-phase transmission system was initiated due to the rising cost of right of way for transmission corridors,

environmental issues, and various stringent licensing laws. Six phase transmission lines can provide the same power capacity with a lower phase-to-phase voltage and smaller, more compact towers compared to a standard double-circuit three-phase line. The geometry of the six-phase compact towers may also aid in the reduction of magnetic fields as well. The research on multiphase generators has started recently and only a few references are available.

Multiphase especially a 6-phase and 12-phase system is found to produce less ripple with a higher frequency of ripple in an ac-dc rectifier system. Thus, 6- and 12-phase transformers are designed to feed a multiples rectifier system and the technology has matured. Recently, a 24- phase and 36-phase transformer system has been proposed for supplying a multi pulse rectifier system. The reason of choice for a 6-, 12-, or 24-phase system is that these numbers are multiples of three and designing this type of system is simple and straightforward. However, increasing the number of phases certainly enhances the complexity of the system. Up to now the even number of phases are available but there is no odd number of phases like 5, 7, 11 etc so we a contribution to do these odd number of phases.

## 2. Multi-Phase

The applicability of multiphase systems is explored in electric power generation, transmission and utilization.

The research on six-phase transmission system was initiated due to the rising of transmission corridors, environmental issues, and various stringent licensing laws.

Five-phase transmission lines can provide the same power capacity with a lower phase-to-phase voltage and smaller, more compact towers compared to a standard double-circuit three-phase line.

It is expected that the proposed connection scheme can be used in drives applications and may also be further explored to be utilized in multiphase power transmission system.

Major advantages of using a multi-phase machine instead of a three-phase machine are higher torque density, greater efficiency, reduced torque pulsations, greater fault tolerance, and reduction.

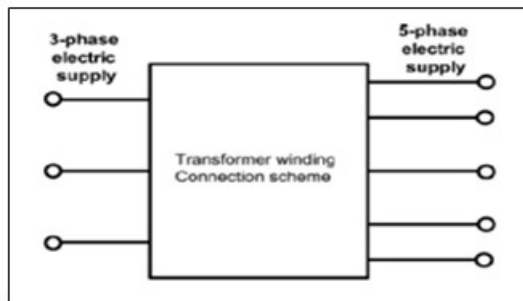

Fig. Block diagram representation

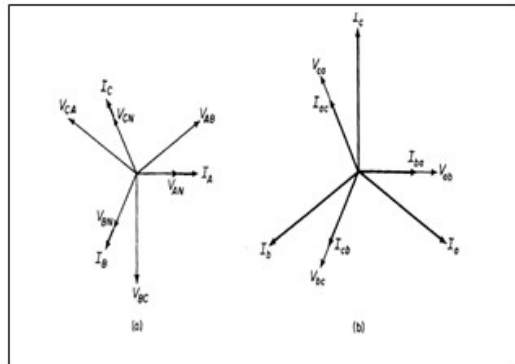

Fig. Phasor diagram of input & output waveform

### 3. Methodology

The input and output supply for the proposed transformation can be arranged in the following manner:

- 1) Input star, outputstar;
- 2) Input star, outputpolygon;
- 3) Input delta, outputstar;
- 4) Input delta, outputpolygon
- 5) Input delta, outputdelta

Three separate cores are designed with each carrying one primary and three secondary coils, except in one core where only two secondary coils are used.

Six terminals of primaries are connected in star and the 16 terminals of secondaries are connected in a different fashion resulting in star or polygon output.

The construction of output phases with requisite phase angles of 72 between each phase is obtained using appropriate turn ratios are illustrated in table below. The turn ratios are different in each phase. The choice of turn ratio is the key in creating the requisite phase displacement in the output phases.

The input phases are designated with letters “X”, “Y”, and “Z” and the output are designated with letters “A”, “B”, “C”, “D”, and “E”. As illustrated in Fig. a The output phase “A” is along the input phase “X. the output phase “B” results from the phasor sum of winding voltage “c6c5 ” and “b1b2”, the output phase “C” is obtained by the phasor sum of winding voltages “a4a3 ” and “b3b4 ”. The output phase “D” is obtained by the phasor addition of winding voltages “a4a3 ” and “c1c2 ” and similarly output phase “E” results from the phasor sum of the winding voltages “c3c4 ” and “b6b5 ”. In this way, five phases are obtained.

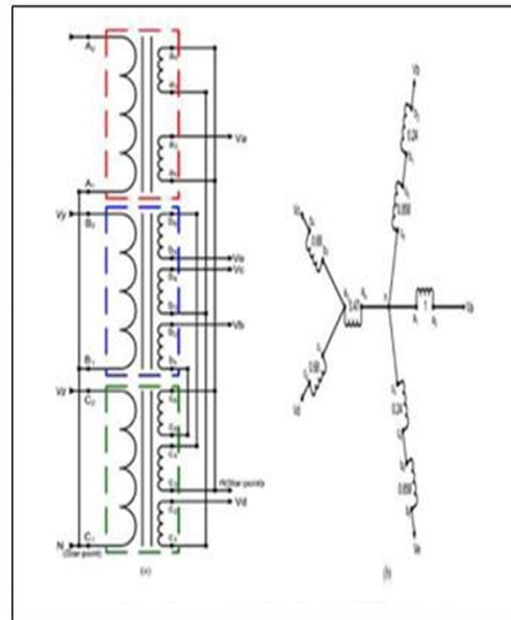

Fig. Input & output connection scheme of proposed system Fig (a) and (b).

The construction of output phases with requisite phase angles of 72 between each phase is obtained using appropriate turn ratios are illustrated in table below. The turn ratios are different in each phase. The choice of turn ratio is the key in creating the requisite phase displacement in the output phases.

The input phases are designated with letters “X”, “Y”, and “Z” and the output are designated with

letters “A”, “B”, “C”, “D”, and “E”. As illustrated in Fig. a

The output phase “A” is along the input phase “X”, the output phase “B” results from the phasor sum of winding voltage “c6c5” and “b1b2”, the output phase “C” is obtained by the phasor sum of winding voltages “a4a3” and “b3b4”. The output phase “D” is obtained by the phasor addition of winding voltages “a4a3” and “c1c2” and similarly output phase “E” results from the phasor sum of the winding voltages “c3c4” and “b6b5”. In this way, five phases are obtained.

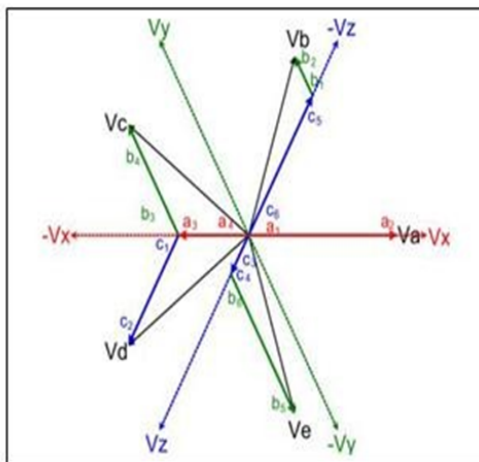

Fig. Phasor Diagram of the Proposed Transformer Connection (Star-Star)

Table. 1 Turns ratio of the proposed transformer scheme

| Primary | Secondary | Turns Ratio (Ns/Np) |
|---------|-----------|---------------------|
| Phase-x | a1a2      | 1                   |
|         | a3a4      | 0.47                |
| Phase-y | b1b2      | 0.24                |
|         | b3b4      | 0.63                |
| Phase-z | c1c2      | 0.63                |
|         | c3c4      | 0.24                |
|         | c5c6      | 0.858               |

*A. Equations*

$$V_a = V_{max} \sin(\omega t)$$

$$V_b = V_{max} \sin\left(\omega t + \frac{2\pi}{5}\right)$$

$$V_c = V_{max} \sin\left(\omega t + \frac{4\pi}{5}\right)$$

$$V_d = V_{max} \sin\left(\omega t - \frac{4\pi}{5}\right)$$

$$V_e = V_{max} \sin\left(\omega t - \frac{2\pi}{5}\right)$$

$$V_x = V_{max} \sin(\omega t)$$

$$V_y = V_{max} \sin(\omega t + 2\pi/3)$$

$$V_z = V_{max} \sin(\omega t - 2\pi/3)$$

Units Input and output waveforms

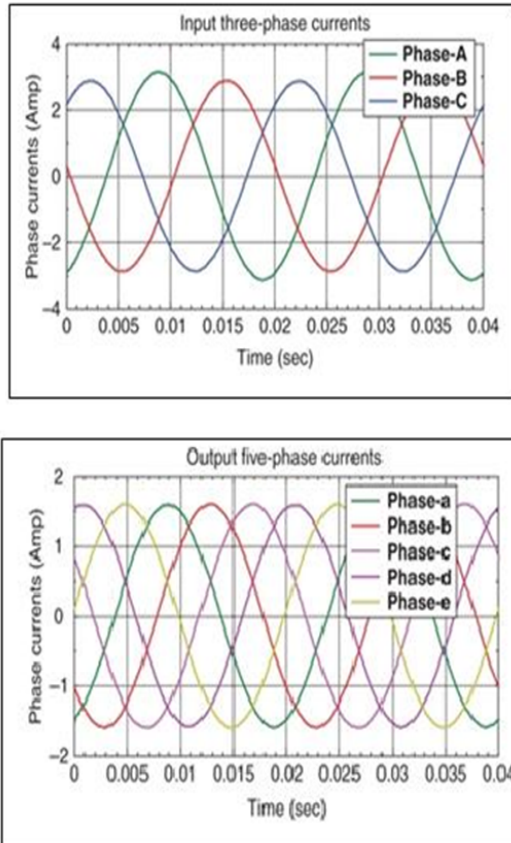

Use either SI or CGS as primary units. (SI units are encouraged.) English units may be used as secondary units (in parentheses). An exception would be the use of English units as identifiers in trade, such as “3.5-inch disk drive”.

[1] Avoid combining SI and CGS units, such as current in amperes and magnetic field in oersteds. This often leads to confusion because equations do not balance dimensionally. If you must use mixed units, clearly state the units for each quantity that you use in an equation.

Do not mix complete spellings and abbreviations of units: “Wb/m<sup>2</sup>” or “webers per square meter”, not “webers/m<sup>2</sup>”. Spell out units when they appear in text: “. . . a few henries”, not “. . . a fewH”.

Use a zero before decimal points: “0.25”, not “.25”. Use “cm<sup>3</sup>”, not “cc”. (*bullet list*)

#### 4. Matlab/Simulink Model Of Three To Five phase Transformation

The designed transformer is at first simulated by using “simpower system” block sets of matlab software. The simulation model is depicted in fig.

and resulting input & output waveforms are illustrated in Fig. given below:

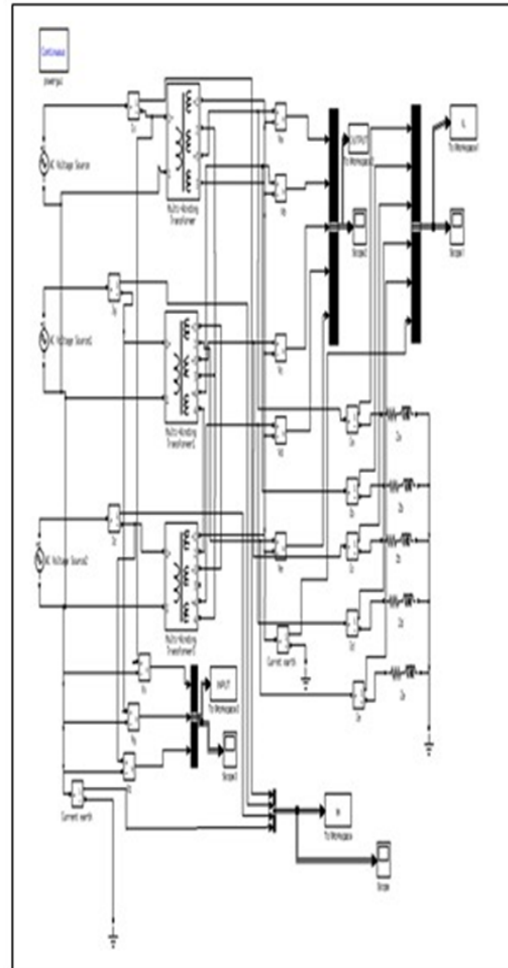

#### 5. Simulink Model Designed in Matlab

It is balanced three-phase input. Individual output phases are, also, shown along with their respective input voltages. The phase Va is not shown because  $V_a = V_x$  (i.e., the input and the output phases are the same).

There was no earth current flowing when both sides neutrals were earthed.

From the input & output waveforms shown below its clearly seen that the output is a balanced five-phase supply for an overall transformer set is slightly lower than the conventional three-phase transformer.

#### 6. Application Of Multiphase System For DC drives

A Multiphase system proves to be advantageous if used for driving DC drives. Ripple content in the DC output of a multiphase system is less as compared to

DC supply obtained from a three phase or a single phase supply.

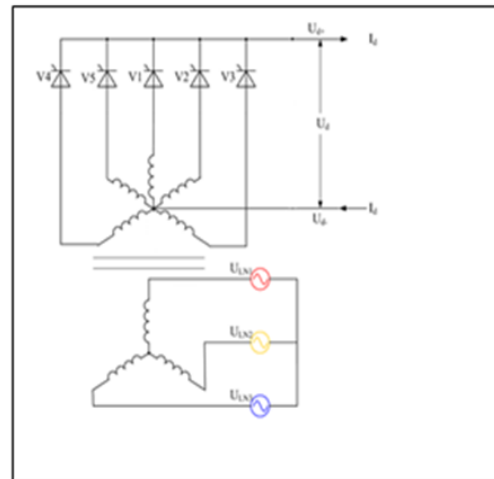
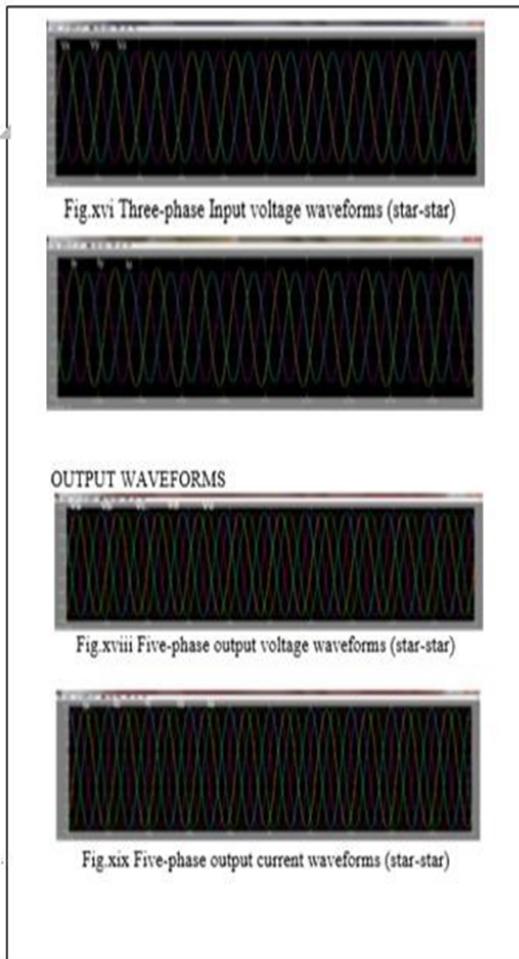

DC output of FIG2 Circuit will contain less ripples as compared to FIG1 circuits output.

## 7. Future scope

It is expected that the proposed connection scheme can be used in drives applications and may also be further explored to be utilized in multiphase power transmission systems.

This transformation is applicable reliably in Multiphase power transmission system, bulk power transfer and in Five-phase permanent magnet generator systems for wind turbine applications.

The research on multiphase generators has started recently and only a few references are available. The present work on multiphase generation has investigated asymmetrical six-phase (two sets of stator windings with

300 phase displacement) induction generator configuration as the solution for use in renewable energy generation.

It is employed in Ship propulsion traction for both hybrid, electric hybrid vehicles and Electric aircraft.

## 8. Conclusion

This paper proposes a new transformer connection scheme to transform the three-phase grid power to a five-phase output supply.

The input and outputs are arranged in different fashion in order to obtain five phase balanced output.

The connection scheme and the phasor diagram along with the turn ratios are illustrated.

Five phase balanced output has been illustrated using Matlab simulations.

The successful implementation of the proposed connection scheme is elaborated by using simulation and experimentation.

## 9. References

- [1]“Transformer Geometry For Three-Phase To Five-Phase Transformation “, P.Mamta1, Beena singh2  
1Department of Electrical Engineering, Lingaya University, (India) 2Assistant professor, Department of Electrical Engineering, Lingaya University, (India) “ International Journal of science Technology & Management” www.ijstm.com ,Volume No.04, Special Issue No.01, February 2015 ISSN (Print) 2394-1529, (Online) 2394-1537
- [2] “Multiphase Electric Machines for Variable Speed Applications” by Emil Levi, Senior Member, IEEE.
- [3]Text book: A.K. sawhney, “Electrical machine Design”, Dhanpatrai&co.
- [4] “Three-Phase To Five-Phase Transformation With A Special Transformer Connection”, “International Journal of Science Technology & Management”, www.ijstm.com Volume No.04, Special Issue No.01, February 2015 ISSN(Print)2394-1529,(Online)2394-1537
- [5]International Journal of Emerging Technology and Advanced Engineering Website: www.ijetae.com (ISSN 2250-2459, ISO 9001:2008 Certified Journal, Volume 3, Issue 8, August 2013).

### Student Details:



**Mr. POLIPAKA VENKATESWARLU** was born in India in the year of 1992. He received B.Tech degree in Electrical and Electronics Engineering from the University of JNTUA, Ananthapuram, in the year of 2013. He pursuing M.Tech degree in Power Systems EEE Department in N.B.K.R. Institute of Science and Technology, S.P.S.R Nellore, Andhra Pradesh State ,India.

Email id: [shiningvenkv@gmail.com](mailto:shiningvenkv@gmail.com)

### Guide Details:



N.Usha has obtained her B. Tech degree from S.V.University and M.Tech degree from JNTU. She has 10 years of teaching experience. She is presently a research scholar at JNTU, Anantapur, A.P. She is working in the area of STATCOM

Email id: [yushareddy@gmail.com](mailto:yushareddy@gmail.com)