

Power Quality Improvement of Grid Interconnection of renewable Energy Based Distribution System

R.Ram Prasad, T.Sravani,

Assistant Professor, Department of EEE,

Department of EEE, N.B.K.R institute of science and technology

N.B.K.R institute of science and technology, Vidya nagar, S.P.S.R Nellore dt.

Vidya nagar, S.P.S.R Nellore dt.

Abstract—Renewable energy resources (RES) are being increasingly connected in distribution systems utilizing power electronic converters. This paper presents a novel control strategy for achieving maximum benefits from these grid-interfacing inverters when installed in 3-phase 4-wire distribution systems. The inverter is controlled to perform as a multi-function device by incorporating active power filter functionality. The inverter can thus be utilized as: 1) power converter to inject power generated from RES to the grid, and 2) shunt APF to compensate current unbalance, load current harmonics, load reactive power demand and load neutral current. All of these functions may be accomplished either individually or simultaneously. With such a control, the combination of grid-interfacing inverter and the 3-phase 4-wire linear/non-linear unbalanced load at point of common coupling appears as balanced linear load to the grid. This new control concept is demonstrated with extensive MATLAB/Simulink simulation studies and validated through digital signal processor-based laboratory experimental results.

Index Terms—Active power filter (APF), distributed generation (DG), distribution system, grid interconnection, power quality (PQ), renewable energy.

I. INTRODUCTION

THE green house gases (such as CO₂) absorb the infrared radiation (IR) and confine the heat in the earth's atmosphere. Primarily, these gases

emissions come from the combustion of fossil fuels based on used energy. As the traditional fossil fuels are non-Renewable Energy Sources. The impact of these fossil fuels encouraged to find alternative energy sources to the fossil fuels. Therefore the RES became one of the important topics for research in the past years [1].

RES integrated at distribution level is termed as distribution generation (DG). As the utility of high penetration of intermittent RES in distribution systems constitute a threat to network in terms of stability, voltage regulation and power quality issues, DG systems are required to act in accordance with technical and regulatory frameworks to protect secure, reliable and cost-effective operation of overall network. Hence DG systems can be actively controlled to enhance the system operation with improved power quality at PCC [2].

Extending use of power electronics based equipment and non-linear loads at PCC generate harmonic currents may weaken the PQ. Due to the wide spread use of non-linear loads significant amounts of harmonic currents are being injected into power systems. These harmonic currents flow through the power system impedance which causes harmonic currents to be drawn by other loads connected at PCC. The persistence of current and voltage harmonics in power system increases losses in the lines, decrease the power factor and may cause timing errors in sensitive electronic equipment's. Balanced 3-phase non-linear loads such as motor drivers, silicon controlled rectifiers (SCR), large uninterruptible power supplies (UPS) produce harmonic currents and voltages which are positive-sequence harmonics like 7th, 13th, etc.

and negative- sequence harmonics like 5th, 11th, etc. Single phase non-linear loads such as switch-mode power supplies in computer equipment produce produce harmonic currents and voltages which are third order zero- sequence harmonics, triplen harmonics like 3rd, 9th, 15th, 21st, etc. Unlike positive and negative- sequence harmonic currents, triplen harmonic currents do not cancel but add arithmetically at the neutral bus. This result's the neutral current that touches magnitudes as high as 1.73 times the phase current. In addition to the risk of cables and transformers overheating, the third harmonic can recede energy efficiency[3].

The method of current harmonics reduction reduces passive LC filters which are simple and low cost. However, these filters have drawbacks as well like large size, tuning and risk of resonance problems. As harmonic pollution is severe in power networks, power system engineer developed dynamic and adjustable solutions to the power quality problems. Such equipment is known as Active Filters (AF's) [4]. These filters are used to compensate the load current harmonics and load unbalance at distribution level and this results in additional cost. In this paper, the features of APF [5] are incorporated in the conventional inverter interfacing renewable using the grid without any additional cost. This inverter is known as |Grid interfacing inverter| and this is incorporated with active power filter functionality to control the performance of malfunction device. Hence this inverter can be used as: 1) power converter to inject power generated from RES to the grid, and ;2) shunt APF to compensate current unbalance, load current harmonics, load reactive power demand and load neutral current. And these functions can be achieved either independently or simultaneously.

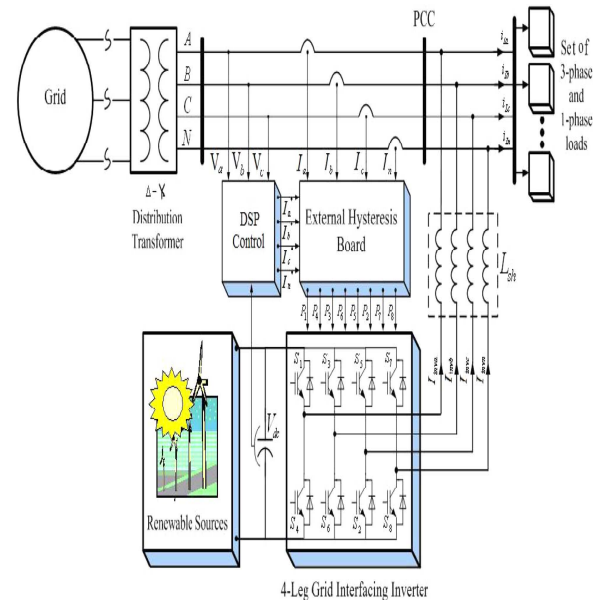

Fig. 1. Schematic of proposed renewable based distributed generation system.

I. SYSTEM INTERPRETATION

Fig.1 shows the proposed system consists of RES connected to the dc-link of a grid-interfacing inverter. As voltage source inverter interfaces the renewable energy source to the grid and delivers the generated power, it is considered as a key element of DG system. The RES may be a DC source or an AC source with rectifier coupled to dc-link.

Usually the variable speed wind turbines generate power at variable ac voltage but the fuel cell and photovoltaic energy sources generate power at variable low dc voltage. Thus the power generated from these renewable sources need power conditioning before connecting to dc-link. The dc-capacitor allows independent control of converters on either side of dc-link and decouples the RES from the grid[6].

A. DC-Link Voltage and Power Control Operation

The power generated due to the intermittent or irregular nature of RES is of variable nature. The dc-link plays an important role in transferring this power from renewable energy source to the grid. Renewable Energy Sources are entitled as current sources connected to the dc-link of a grid-interfacing inverter. Fig. 2 shows the structured representation of power transfer from the RES to

the grid through dc-link.

The current injected at voltage level by renewable into dc-link can be calculated as

$$I_{dc1} = P_{RES} / V_{dc} \quad (1)$$

Where P_{RES} is power generated from RES. The current flow from other dc-link can be characterized as,

$$I_{dc2} = P_{inv} / V_{dc} = (P_g + P_{loss}) / V_{dc} \quad (2)$$

Where P_{inv} is the total power available at grid-interfacing inverter side P_g is the active power supplied to the grid and P_{loss} is the inverter losses, if inverter losses are negligible then $P_{RES} = P_g$.

B. Control Scenario

Fig.4 shows the control diagram of grid- interfacing inverter for a 3-phase 4-wire system. The fourth leg of inverter is used to compensate the neutral current of load. The aim of proposed approach I to regulate the power at PCC during: 1) $P_{RES} = 0$; 2) $P_{RES} < P_L$ (Total Load Power); 3) $P_{RES} > P_L$; The inverter always draws/supplies necessary active power from/to the grid during the power management operation. The given control approach compensates harmonics, unbalance, and neutral current when the load connected to PCC is non-linear or unbalanced or the combination of both the given approach also compensates the harmonics, unbalance, and neutral current.

The duty ratio of inverter switches are varied in a power cycle such that the combination of load and Thus the output of dc-link voltage regulator results in an active current I_m . The multiplication of active current component (I_m) with unity grid voltage vector templates (U_a , U_b and U_c) generates the reference grid currents (i_m^*) is put to zero, being the instantaneous sum of balanced grid currents the grid synchronizing angle (θ) is obtained from phase locked loop (PLL) is used to generate unit vector template.

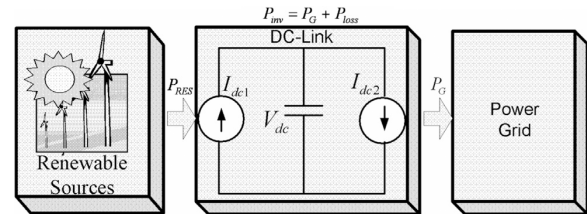

Fig. 2. DC-Link equivalent diagram.

$$U_a = \sin(\theta) \quad (3)$$

$$U_b = \sin(\theta - 2\pi/3) \quad (4)$$

$$U_c = \sin(\theta + 2\pi/3) \quad (5)$$

The actual dc-link voltage (V_{dc}) is sensed and passed through a first-order low pass filter (LPF) to eliminate the presence of switching ripples on the dc-link voltage and in the generated reference current signals. To maintain a constant dc-link voltage under varying generation and load conditions, the difference of this filtered dc-link voltage and reference dc-link voltage (V_{dc}^*) is given to a fuzzy logic controller. The instantaneous values of reference three phase grid currents can be calculated as

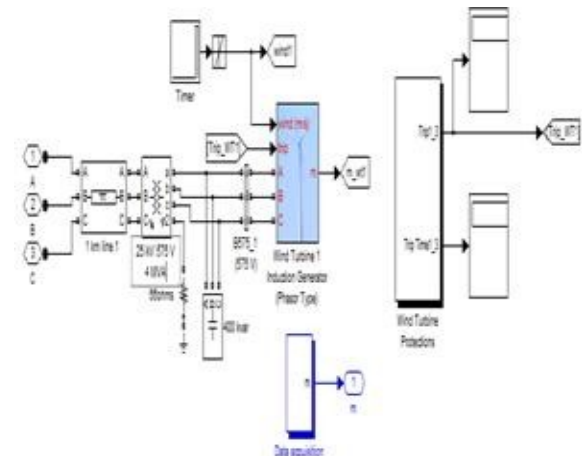

Fig. 3. Simulink diagram of wind farm.

$$I_a^* = I_m \cdot u_a \quad (6)$$

$$I_b^* = I_m \cdot u_b \quad (7)$$

$$I_c^* = I_m \cdot u_c \quad (8)$$

The remaining neutral current due to the loads connected to the neutral conductor should be

compensated by forth leg of grid-interfacing inverter and should be drawn from the grid. In alternate words, the reference current for the grid neutral current is considered as zero and can be expressed as The reference grid currents are compared with actual grid currents

($I_a^*, I_b^*, I_c^*, I_n^*$) to compute the current errors as:

$$I_a \text{ error}^* = I_a^* - I_a \quad (10)$$

$$I_b \text{ error}^* = I_b^* - I_b \quad (11)$$

$$I_c \text{ error}^* = I_c^* - I_c \quad (12)$$

The current errors are given to hysteresis current controller. Fig.4 shows the gate drivers of grid

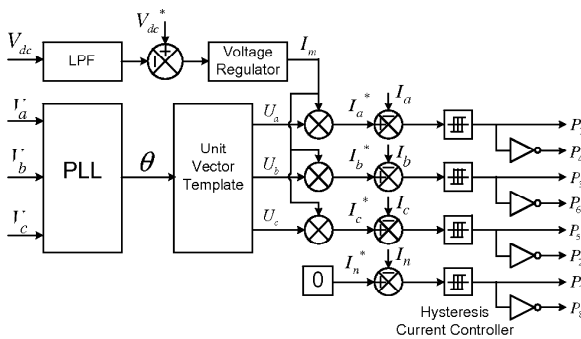

Fig. 4. Block diagram representation of grid-interfacing inverter control.

interfacing inverter, P1 to P8 are the switching pulses generated from the hysteresis controller.

C. FUZZY LOGIC CONTROLLER (FLC)

The disadvantage of PI controller is its inability to react to abrupt changes in the error signal, ϵ , because it is only capable of determining the instantaneous value of the error signal without considering the change of the rise and fall of the error, which in mathematical terms is the derivative of the error denoted as $\Delta\epsilon$. To solve this problem, Fuzzy logic control [7] as shown in the fig.5is

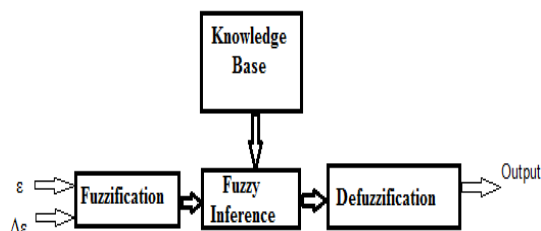

Fig. 5.FLC structure

proposed. The disadvantage of PI controller Is its inability to react to abrupt changes in the error Signal, ϵ , as it is only capable of determining the instantaneous value of the error signal without considering the change of rise and fall of the error. This change in rise and fall of error is mathematically derived as $\Delta\epsilon$. Fig.5 shows the basic representation of Fuzzy logic control (FLC) to resolve the problem

The output control signal can be determined in an inference engine with a rule in the form of : "IF ϵ is AND $\Delta\epsilon$ is THEN output is" Hence, the value of output can be changed accordingly to the value of error signal, ϵ , and the rate-of-error $\Delta\epsilon$ the trail and error methods are used to determine the structure and value of the rule base and it is also done through experimentation.

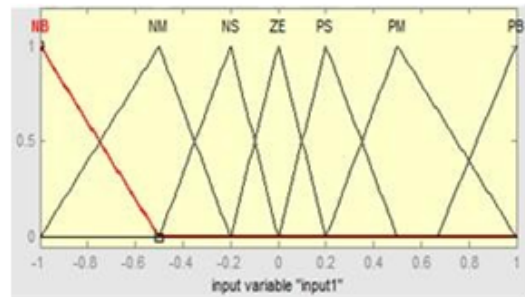

Fig. 6. Membership functions of input error(ϵ)

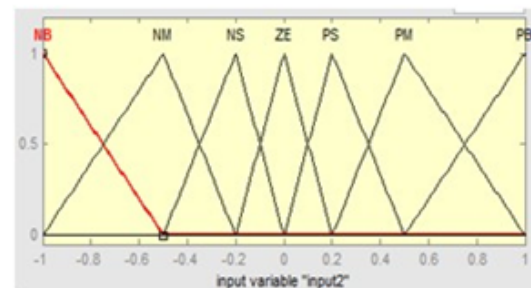

Fig. 7. Membership functions of input change in error($\Delta\epsilon$)

TABLE I. FLC Rule Base

		Error(e)						
Change in error(Δe)	e	NB	NM	NS	ZE	PS	PM	PB
	Δe	NB	NM	NS	ZE	PS	PM	PB
NB	NB	NB	NB	NB	NB	NM	NS	ZE
NM	NB	NB	NM	NM	NM	NS	ZE	PS
NS	NB	NM	NS	NS	ZE	PS	PM	PM
ZE	NB	NM	NS	ZE	PS	PM	PB	PB
PS	NM	NS	ZE	PS	PS	PM	PB	PB
PM	NS	ZE	PS	PM	PM	PB	PB	PB
PB	ZE	PS	PM	PB	PB	PB	PB	PB

All the variables of fuzzy subsets for the inputs e and Δe can be defined as (NB, NM, NS, Z, PS, PM, PB). Fig.6&7 represents the membership functions of inputs e and Δe . Table1 illustrates Fuzzy Control Rule.

SWITCHING CONTROL

The hysteresis control is used to keep the controlled current inside a defined band around the references as shown in the Fig. 4. The status for the switches can be determined according to the error. When the current increases and error exceeds a certain positive value, the status of switches changes and the current begins to decrease until the error reaches a certain negative. Before $t=0.8s$, the grid interfacing inverter is not connected to network, hence Value and again the status of switches change. Based on hysteresis strategies, the non-linear ones allow faster dynamic response and better robustness with respect to the variation of the non linear load compared with linear controllers. A drawback [8] of the hysteresis strategies is the switching frequency is not constant and can generate a large side harmonics.

III. SIMULATIONRESULTS

To verify the proposed control strategy, an extensive simulation strategy is carried out using MATLAB/Simulink. The 4-leg grid interfacing inverter is actively controlled under varying renewable generating condition in order to achieve balanced sinusoidal grid currents at unity power factor.

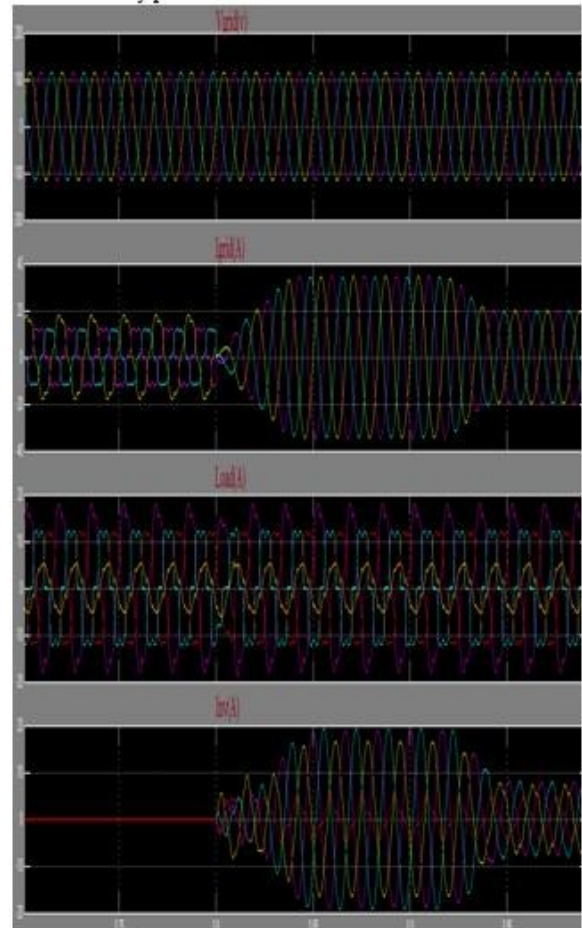

Fig. 8. Simulation results : (a) grid voltages,(b) grid currents,(c) Load currents, (d) inverter currents

Fig.8 shows the waveforms of grid voltages, grid currents, unbalanced load current and inverter currents. Fig. 9 shows the corresponding active and reactive of grid (PQ grid), load (PQ load) and inverter (PQ inv). Positive values of grid active-reactive powers and inverter active-reactive powers imply that these powers flow from grid side towards PCC and from inverter towards PCC, correspondingly. The active and reactive powers absorbed by the load are denoted by positivesigns.the grid currents in Fig.8 (b) are same as unbalanced nonlinear load currentsFig.8(c). At $t=0.8s$, the grid interfacing inverter is now connected to network. Fig.8 (b) shows the grid current starts changing to sinusoidal balanced from unbalanced nonlinear current. At this instant, active power injected by the inverter from RES is shown in Fig.9. The load power demand is less than the generated power and the additional power in fed

back to the grid. The grid is receiving power from RES after 0.85s and it is indicated by vesign.

By considering the load power demand as constant, the power generated from RES at $t=0.85s$ is increased to verify the system performance under variable power generation and hence it increases the magnitude of inverter current.

At $t=0.95s$ generation of power from RES is reduced. The active and re-active power flows between the inverter, load and grid during increase and decrease of energy generation from RES can be noticed from Fig.9.

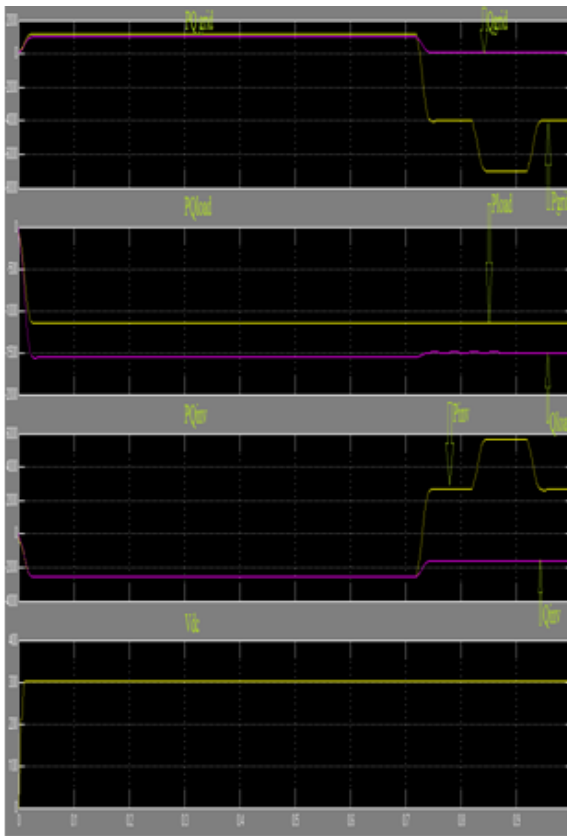

Fig. 9. Simulation results : (a) PQ grid, (b) PQ load, (c) PQ inverter, (d) dc link voltage using Fuzzy Logic Controller.

IV. CONCLUSION

This paper presented the control of grid- interfacing inverter to improve the power quality at PCC for a 3-phase 4-wire DG System. Grid- interfacing

inverter can be effectively utilized for power conditioning without affecting its normal operation of power transfer. This inverter can be utilized to inject the power generated from RES to the grid and/or to operate as a shunt Active Power Filter (APF). This process eliminates the need for additional power conditioning equipment to improve of power at PCC. MATLAB/Simulink simulation and Fuzzy logic based results have validated this process and thus this inverter can be utilized as a multifunction device.

REFERENCES

- [1] MukhtiarSingh, VinodKhadkikar, AmrishChandra, and Rajiv K.Varma, —Grid Interconnection of Renewable Energy Sources at the Distribution Level With Power-Quality Improvement Features, IEEE Trans. Power Electron., vol. 26, no. 1, Jan.2011.
- [2] J. M. Guerrero, L. G. de Vicuna, J. Matas, M.Castilla, and J.Miret, —A wireless controller to enhance dynamic performance of parallel in-verters in distributed generation systems, IEEE Trans. Power Elec-tron., vol. 19, no. 5, pp. 1205–1213, Sep. 2004.
- [3] J. H. R. Enslin and P. J. M.Heskes, —Harmonic interaction between a large number of distributed power inverters and the distribution network, IEEE Trans. Power Electron., vol. 19, no. 6, pp. 1586–1593, Nov. 2004.
- [4] Mehmet Ucar, EnginOzdemir "Control of a 3-phase 4-leg active power filter under non- ideal mains voltage condition" Electric Power Systems Research 78 (2008) 58–73.
- [5] Bhim Singh, Kamal Al-Haddad, Senior Member, IEEE, and Amrish Chandra, Member, IEEE "A Review of Active Filters for Power Quality Improvement", IEEE Trans. Elec-tron., vol. 46, no. 5, Sep. 1999.
- [6] F. Blaabjerg, R. Teodorescu, M. Liserre, and A.V.Timbus, —Overview of control and grid synchronization for distributed power generation systems, IEEE Trans. Ind. Electron., vol. 53, no. 5, pp. 1398–1409, Oct.2006.
- [7] M.Bhanu Siva, M.R.P Reddy, Ch.Rambabu "Power Quality Improvement of Three- phase four-wire DSTATCOM with Fuzzy logic Controller" ICSIT., vol.2, pp. 2273- 2273., 2011.
- [8] M. Nejad, S. Pierfederici, J.P. Martin, F. Meibody-Tabar, —Study of an hybrid current

controller suitable for DC–DC or DC–AC applications, IEEE Transactions on Power Electronics, vol. 22, pp. 2176–2186. November 2007.

in Power systems in EEE Department in N.B.K.R college of engineering and Technology ,VIDYA NAGAR, , S.P.S.R. Nellore dt.

mail id: sravanisravs60@gmail.com

Guide Details



Born in Andhra Pradesh..studied B.E, E.E.E. in srishirdisai engineering college, Bangalore university, Karnataka during 1997-2001. completed M.Tech in srivenkateswara college of engineering, S.V. University, Tirupathi with power system operation and control specialization during 2005-2007. worked as assistant professor in dept of EEE in Sri Venkageswara College of Engineering, tirupathi during 2007 Oct - 2010 Aug. currently working as assistant professor in N.B.K.R.I.S.T, Vidyanagar, S.P.S.R. Nellore dt.. from Aug 2010 to till date.

Email id:ramprasada.rontala@gmail.com

Student Details



Ms. SRAVANI was born in India.She pursuing M.Tech degree