

# An Improved IUPQC Controller to Provide Additional Grid-Voltage Regulation with fuzzy logic controller

*Sk Saheenabi<sup>1</sup>, Shaik Dawood<sup>2</sup>*

<sup>1</sup>M.Tech(PS) Nimra Institute of Science and Technology, Vijayawada, AP

<sup>2</sup>Asst Professor Dept of EEE, Nimra Institute of Science and Technology, Vijayawada, AP

## Abstract

This paper presents an improved controller for the dual topology of the unified power quality conditioner (iUPQC) extending its applicability in power-quality compensation, as well as in micro grid applications. By using this controller, beyond the conventional UPQC power quality features, including voltage sag/swell compensation, the iUPQC will also provide reactive power support to regulate not only the load-bus voltage but also the voltage at the grid-side bus. In other words, the iUPQC will work as a static synchronous compensator (STATCOM) at the grid side, while providing also the conventional UPQC compensations at the load or micro grid side here the controlling is used in fuzzy logic controller.

## I. INTRODUCTION

CERTAINLY, power-electronics devices have brought about great technological improvements. However, the increasing number of power-electronics-driven loads used generally in the industry has brought about uncommon power quality problems. In contrast, power-electronics-driven loads generally require ideal sinusoidal supply voltage in order to function properly, whereas they are the most responsible ones for abnormal harmonic currents level in the distribution system. In this scenario,

devices that can mitigate these drawbacks have been developed over the years. Some of the solutions involve a flexible compensator, known as the unified power quality conditioner (UPQC) and the static synchronous compensator (STATCOM). The power circuit of a UPQC consists of a combination of a shunt active filter and a series active filter connected in a back-to-back configuration. This combination allows the simultaneous compensation of the load current and the supply voltage, so that the compensated current drawn from the grid and the compensated supply voltage delivered to the load are kept balanced and sinusoidal. The dual topology of the UPQC, i.e., the iUPQC, where the shunt active filter behaves as an ac-voltage source and the series one as an ac-current source, both at the fundamental frequency. This is a key point to better design the control gains, as well as to optimize the *LCL* filter of the power converters, which allows improving significantly the overall performance of the compensator. The STATCOM has been used widely in transmission networks to regulate the voltage by means of dynamic reactive power compensation. Nowadays, the STATCOM is largely used for voltage regulation, whereas the UPQC and the iUPQC have been selected as solution for more specific applications. Moreover, these last ones are used only in

particular cases, where their relatively high costs are justified by the power quality improvement it can provide, which would be unfeasible by using conventional solutions. By joining the extra functionality like a STATCOM in the iUPQC device, a wider scenario of applications can be reached, particularly in case of distributed generation in smart grids and as the coupling device in grid-tied micro grids. The performance of the iUPQC and the UPQC was compared when working as UPQCs. The main difference between these compensators is the sort of source emulated by the series and shunt power converters. In the UPQC approach, the series converter is controlled as a non-sinusoidal voltage source and the shunt one as a non-sinusoidal current source. Hence, in real time, the UPQC controller has to determine and synthesize accurately the harmonic voltage and current to be compensated. On the other hand, in the iUPQC approach, the series converter behaves as a controlled sinusoidal current source and the shunt converter as a controlled sinusoidal voltage source. This means that it is not necessary to determine the harmonic voltage and current to be compensated, since the harmonic voltages appear naturally across the series current source and the harmonic currents flow naturally into the shunt voltage source. In actual power converters, as the switching frequency increases, the power rate capability is reduced. Therefore, the iUPQC offers better solutions if compared with the UPQC in case of high-power applications, since the iUPQC compensating references are pure sinusoidal waveforms at the fundamental frequency. Moreover, the UPQC has higher switching losses due to its higher switching frequency.

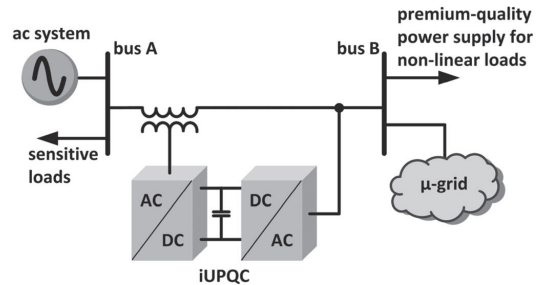

**Fig1 : simulation circuit**

This paper proposes an improved controller, which expands the iUPQC functionalities. This improved version of iUPQC controller includes all functionalities of those previous ones, including the voltage regulation at the load-side bus, and now providing also voltage regulation at the grid-side bus, like a STATCOM to the grid. Experimental results are provided to validate the new controller design.

## II. EQUIPMENT PLICABILITY

In order to clarify the applicability of the improved iUPQC controller, Fig. 1 depicts an electrical system with two buses in spotlight, i.e., bus A and bus B. Bus A is a critical bus of the power system that supplies sensitive loads and serves as point of coupling of a micro grid. Bus B is a bus of the micro grid, where nonlinear loads are connected, which requires premium-quality power supply. The voltages at buses A and B must be regulated, in order to properly supply the sensitive loads and the nonlinear loads. The effects caused by the harmonic currents drawn by the nonlinear loads should be mitigated, avoiding harmonic voltage propagation to bus A. The use of a STATCOM to guarantee the voltage regulation at bus A is not enough because the harmonic currents drawn by the nonlinear loads are not mitigated. On the other hand, a UPQC or an iUPQC between bus A and bus B can compensate the harmonic currents of the nonlinear loads and compensate the voltage at bus B, in terms of voltage

harmonics, unbalance, and sag/swell. Nevertheless, this is still not enough to guarantee the voltage regulation at bus A. Hence, to achieve all the desired goals, a STATCOM at bus A and a UPQC (or an iUPQC) between buses A and B should be employed. However, the costs of this solution would be unreasonably high. An attractive solution would be the use of a modified iUPQC controller to provide also reactive power support to bus A, in addition to all those functionalities of this equipment. Note that the modified iUPQC serves, as an intertie between buses A and B. Moreover, the micro grid, connected to the bus B could be a complex system comprising distributed generation, energy management system, and other

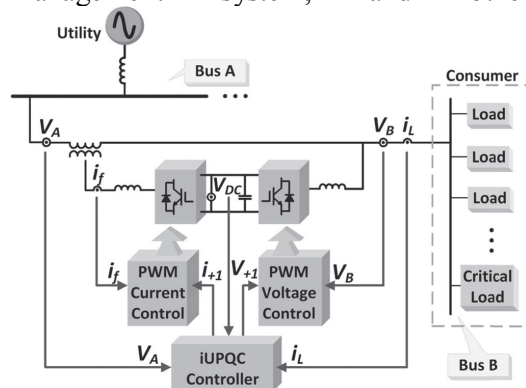

**Fig 2: An modified IUPQC**

control systems involving microgrid, as well as smart grid. In summary, the modified iUPQC can provide the following functionalities:

- “smart” circuit breaker as an intertie between the grid and the microgrid;
- energy and power flow control between the grid and the microgrid (imposed by a tertiary control layer for the microgrid);
- reactive power support at bus A of the power system;
- voltage/frequency support at bus B of the microgrid;
- harmonic voltage and current isolation between bus A and bus B (simultaneous grid-voltage and load-current active filtering capability);

f) voltage and current imbalance compensation.

Fig. 2 depicts, in detail, the connections and measurements of the iUPQC between bus A and bus B. According to the conventional iUPQC controller, the shunt converter imposes a controlled sinusoidal voltage at bus B, which corresponds to the aforementioned functionality (d). As a result, the shunt converter has no further degree of freedom in terms of compensating active- or reactive-power variables to expand its functionality. On the other hand, the series converter of a conventional iUPQC uses only an active-power control variable  $p$ , in order to synthesize a fundamental sinusoidal current drawn from bus A, corresponding to the active power demanded by bus B. If the dc link of the iUPQC has no large energy storage system or even no energy source, the control variable  $p$  also serves as an additional active-power reference to the series converter to keep the energy inside the dc link of the iUPQC balanced. In this case, the losses in the iUPQC and the active power supplied by the shunt converter must be quickly compensated in the form of an additional active power injected by the series converter into the bus

B. The iUPQC can serve as

- “smart” circuit breaker and as
- power flow controller between the grid and the micro grid only if the compensating active- and reactive-power references.

### III. IMPROVED IUPQC CONTROLLER

#### A. Main Controller

Fig. 2 depicts the iUPQC hardware and the measured units of a three-phase three-wire system that are used in the controller. Fig. 3 shows the proposed controller. The controller inputs are the voltages at buses

A and B, the current demanded by bus B ( $iL$ ), and the voltage  $vDC$  of the common dc link. The outputs are the shunt-voltage reference and the series-current reference to the pulsewidth modulation (PWM) controllers. The voltage and current PWM controllers can be as simple as those employed in or be improved further to better deal with voltage and current imbalance and harmonics. First, the simplified Clark transformation is applied to the measured variables. As example of this transformation, the grid voltage in the  $\alpha\beta$ -reference frame can be calculated as

$$\begin{bmatrix} V_{A\_ \alpha} \\ V_{A\_ \beta} \end{bmatrix} = \begin{bmatrix} 1 & 1/2 \\ 0 & \sqrt{3}/2 \end{bmatrix} \begin{bmatrix} V_{A\_ ab} \\ V_{A\_ bc} \end{bmatrix}. \quad (1)$$

The shunt converter imposes the voltage at bus B. Thus, it is necessary to synthesize sinusoidal voltages with nominal amplitude and frequency. Consequently, the signals sent to the PWM controller are the phase-locked loop (PLL) outputs with amplitude equal to 1 p.u. There are many possible PLL algorithms. In the original iUPQC approach as presented in [14], the shunt-converter voltage reference can be either the PLL outputs or the fundamental positive-sequence component  $V_{A+1}$  of the grid voltage (bus A in Fig. 2). The use of  $V_{A+1}$  in the controller is useful to minimize the circulating power through the series and shunt converters, under normal operation, while the amplitude of the grid voltage is within an acceptable range of magnitude. However, this is not the case here, in the modified iUPQC controller, since now the grid voltage will be also regulated by the modified iUPQC. In other words, both buses will be regulated independently to track their reference values. The series converter synthesizes the current drawn from the grid bus (bus A). In the original approach of iUPQC, this current is calculated through the average active power required by the loads  $PL$  plus the power  $PLoss$ . The load active power can be estimated by

$$P_L = V_{+1\_ \alpha} \cdot i_{L\_ \alpha} + V_{+1\_ \beta} \cdot i_{L\_ \beta} \quad (2)$$

where  $iL\_ \alpha$ ,  $iL\_ \beta$  are the load currents, and  $V_{+1\_ \alpha}$ ,  $V_{+1\_ \beta}$  are the voltage references for the shunt converter. A low-pass filter is used to obtain the average active power ( $PL$ ). The losses in the power converters and the circulating power to provide energy balance inside the iUPQC are calculated indirectly from the measurement of the dc-link voltage. In other words, the power signal  $PLoss$  is determined by a proportional– integral (PI) controller by comparing the measured dc voltage  $VDC$  with its reference value. The additional control loop to provide voltage regulation like a STATCOM at the grid bus is represented by the control signal  $QSTATCOM$ . This control signal is obtained through a PI controller, in which the input variable is the error between the reference value and the actual aggregate voltage of the grid bus, given by

$$V_{col} = \sqrt{V_{A+1\_ \alpha}^2 + V_{A+1\_ \beta}^2}. \quad (3)$$

The sum of the power signals  $PL$  and  $PLoss$  composes the active-power control variable for the series converter of the iUPQC ( $p$ ) described in Section II. Likewise,  $QSTATCOM$  is the reactive-power control variable  $q$ . Thus, the current references  $i_{+1\alpha}$  and  $i_{+1\beta}$  of the series converter are determined by

$$\begin{bmatrix} i_{+1\_ \alpha} \\ i_{+1\_ \beta} \end{bmatrix} = \frac{1}{V_{A+1\_ \alpha}^2 + V_{A+1\_ \beta}^2} \begin{bmatrix} V_{A+1\_ \alpha} & V_{A+1\_ \beta} \\ V_{A+1\_ \beta} & -V_{A+1\_ \alpha} \end{bmatrix} \times \begin{bmatrix} P_L + P_{Loss} \\ Q_{STATCOM} \end{bmatrix}. \quad (4)$$

Fig. 3 depicts the apparent power of the series and shunt power converters. In these figures, the ksag/swell-axis and the PF-axis are used to evaluate the power flow in the series and shunt power converters according to the sag/swell voltage disturbance and the load power consumption, respectively. The power flow in the series converter indicates that a high power is required in case of sag voltage disturbance with high active power load consumption. In this situation, an increased Pinner arises and high rated



power converters are necessary to ensure the disturbance compensation. Moreover, in case of compensating sag/swell voltage disturbance with high reactive power load consumption, only the shunt converter has high power demand, since Pinner decreases. It is important to highlight that, for each PF value, the amplitude of the apparent power is the same for capacitive or inductive loads. In other words, Fig. 5 is the same for QB capacitive or inductive. If the iUPQC performs all original UPQC functionalities together with the STATCOM functionality, the voltage at bus A is also regulated with the same phase and magnitude, that is,  $V_A = V_B = V_N$ , and then, the positive sequence the

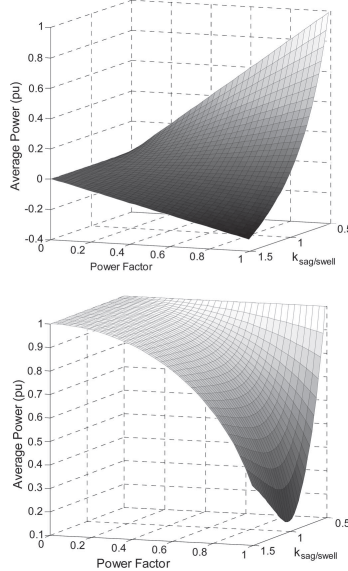

Fig 3: Apparent power of the series and shunt converters, respectively.

#### IV. EXPERIMENTAL RESULTS

The improved iUPQC controller, as shown in Fig. 3, was verified in a 5-kVA prototype, whose parameters are presented. The controller was embedded in a fixed-point digital signal processor (TMS320F2812). In order to verify all the power quality issues described in this paper, the iUPQC was connected to a grid with a voltage sag system, as depicted in Fig. 4. The voltage sag system was

composed by an inductor ( $LS$ ), a resistor ( $R_{rmSag}$ ), and a breaker ( $SSag$ ). To cause a voltage sag at bus A,  $SSag$  is closed. At first, the source voltage regulation was tested with no load connected to bus B. In this case, the iUPQC behaves as a STATCOM, and the breaker  $SSag$  is closed to cause the voltage sag.

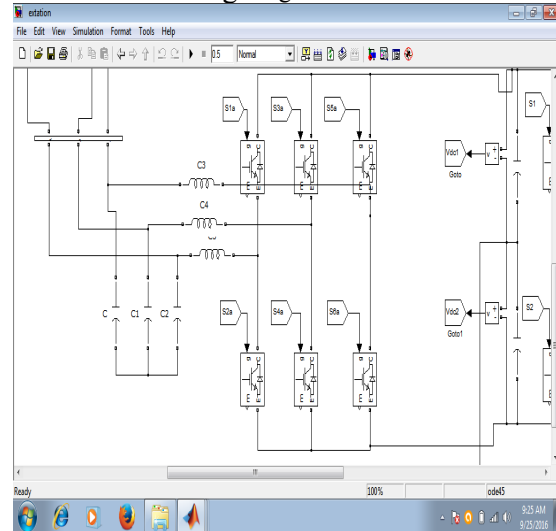

Fig 4: simulation circuit

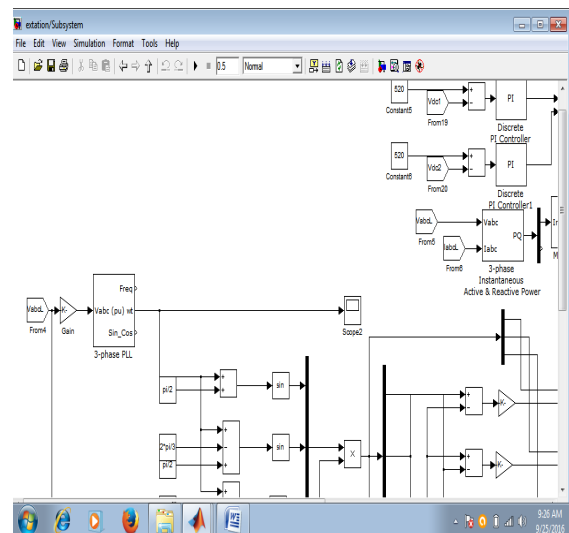
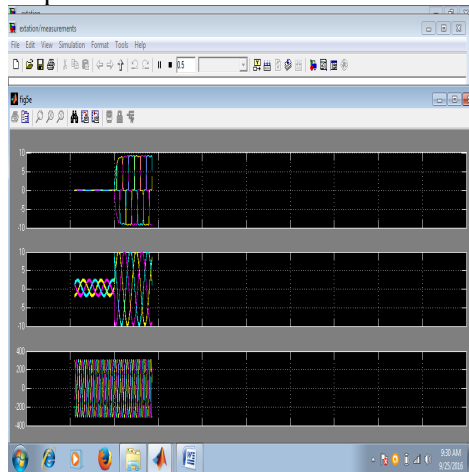

Fig 5: sub system

To verify the grid-voltage regulation (see Fig. 7), the control of the  $QSTATCOM$  variable is enabled to compose (4) at instant  $t = 0$  s. In this experimental case,  $LS = 10$  mH, and  $RSag = 7.5 \Omega$ . Before the  $QSTATCOM$  variable is enabled, only the dclink and the voltage at bus B are regulated, and there is a voltagesag at bus

A, as shown in Fig. 6. After  $t = 0$ s, the iUPQC starts to draw reactive current from bus A, increasing the voltage until its reference value. As shown in Fig. 6, the load voltage at bus B is maintained regulated during all the time, and the grid-voltage regulation of bus A has a fast response.



**Fig. 7.** iUPQC response at no load condition:

(a) grid voltages  $V_A$ , (b) load voltages  $V_B$ , and (c) grid currents

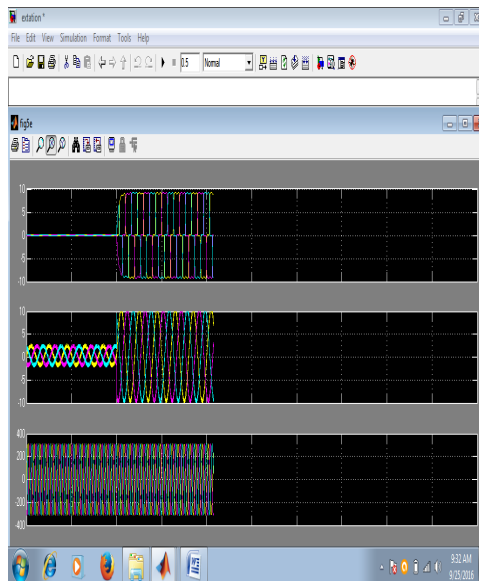

**Fig. 8.** iUPQC transitory response during the connection of a threephase diode rectifier: (a) load currents, (b) grid currents, (c) load voltages and (d) grid voltages

Next, the experimental case was carried out to verify the iUPQC performance during the connection of a nonlinear load with the iUPQC already in operation. The load is a three phase diode rectifier with a series  $RL$  load at the dc link ( $R = 45 \Omega$  and  $L = 22 \text{ mH}$ ), and the circuit breaker  $SSag$  is permanently closed, with a  $LS = 10 \text{ mH}$  and a  $RSag = 15 \Omega$ . In this way, the voltage-sag disturbance is increased due to the load connection. In Fig. 8, it is possible to verify that the iUPQC is able to regulate the voltages at both sides of the iUPQC, simultaneously. Even after the load connection, at  $t = 0 \text{ s}$ , the voltages are still regulated, and the currents drawn from bus

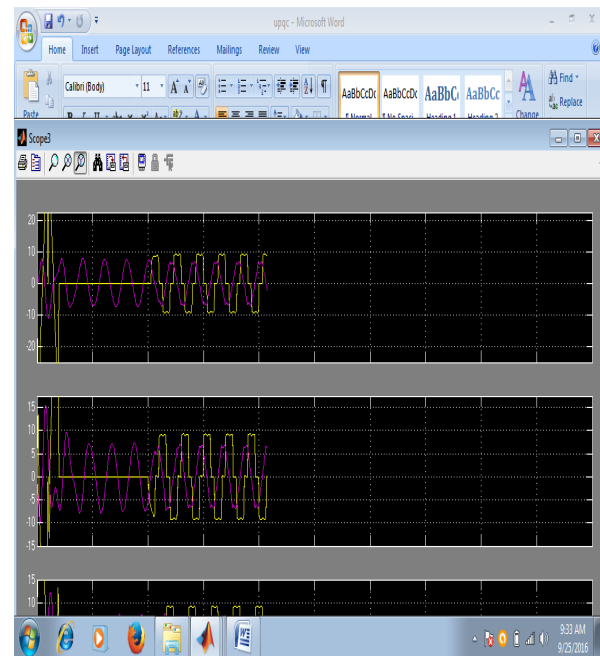

**Fig. 9.** iUPQC transitory response during the connection of a twophase diode rectifier: (a) load currents, (b) source currents, (c) load voltages, and (d) source voltages

Finally, the same procedure was performed with the connection of a two-phase diode rectifier, in order to better verify the mitigation of power quality issues. The diode rectifier has the same dc load ( $R = 45 \Omega$  and  $L = 22 \text{ mH}$ ) and the same voltage sag ( $LS = 10 \text{ mH}$  and  $R_{rmsag} = 15\Omega$ ). Fig. 9 depicts the

transitory response of the load connection. Despite the twophase load currents, after the load connection at  $t = 0$  s, the three-phase current drained from the grid has a reduced unbalanced component. Likewise, the unbalance in the voltage at bus A is negligible. Unfortunately, the voltage at bus B has higher unbalance content. These components could be mitigated if the shunt compensator works as an ideal voltage source, i.e., if the filter inductor could be eliminated. In this case, the unbalanced current of the load could be supplied by the shunt converter, and the voltage at the bus B could be exactly the voltage synthesized by the shunt converter. Therefore, without filter inductor, there would be no unbalance voltage drop in it and the voltage at bus B would remain balanced. However, in a practical case, this inductor cannot be eliminated, and an improved PWM control to compensate voltage unbalances, as mentioned in Section III, is necessary.

## V. CONCLUSION

In the improved iUPQC controller, the currents synthesized by the series converter are determined by the average active power of the load and the active power to provide the dc-link voltage regulation, together with an average reactive power to regulate the grid-bus voltage. In this manner, in addition to all the power-quality compensation features of a conventional UPQC or an iUPQC, this improved controller also mimics a STATCOM to the grid bus. This new feature enhances the applicability of the iUPQC and provides new solutions in future scenarios involving smart grids and microgrids, including distributed generation and energy storage systems to better deal with the inherent variability of renewable resources such as solar and wind power. Moreover, the improved iUPQC controller may justify the costs and promotes the iUPQC applicability in

power quality issues of critical systems, where it is necessary not only an iUPQC or a STATCOM, but both, simultaneously. Despite the addition of one more power-quality compensation feature, the grid-voltage regulation reduces the inner-loop circulating power inside the iUPQC, which would allow lower power rating for the series converter. The experimental results verified the improved iUPQC goals. The grid-voltage regulation was achieved with no load, as well as when supplying a three-phase nonlinear load. These results have demonstrated a suitable performance of voltage regulation at both sides of the iUPQC, even while compensating harmonic current and voltage imbalances.

## REFERENCES

- [1] K. Karanki, G. Geddada, M. K. Mishra, and B. K. Kumar, "A modified three-phase four-wire UPQC topology with reduced DC-link voltage rating," *IEEE Trans. Ind. Electron.*, vol. 60, no. 9, pp. 3555–3566, Sep. 2013.
- [2] V. Khadkikar and A. Chandra, "A new control philosophy for a unified power quality conditioner (UPQC) to coordinate load-reactive power demand between shunt and series inverters," *IEEE Trans. Power Del.*, vol. 23, no. 4, pp. 2522–2534, Oct. 2008.
- [3] K. H. Kwan, P. L. So, and Y. C. Chu, "An output regulation-based unified power quality conditioner with Kalman filters," *IEEE Trans. Ind. Electron.*, vol. 59, no. 11, pp. 4248–4262, Nov. 2012.
- [4] A. Mokhtatpour and H. A. Shayanfar, "Power quality compensation as well as power flow control using of unified power quality conditioner," in *Proc. APPEEC*, 2011, pp. 1–4.
- [5] J. A. Munoz *et al.*, "Design of a discrete-time linear control strategy for a multicell UPQC," *IEEE Trans. Ind. Electron.*, vol. 59, no. 10, pp. 3797–3807, Oct. 2012.



[6] V. Khadkikar and A. Chandra, "UPQC-S: A novel concept of simultaneous voltage sag/swell and load reactive power compensations utilizing series inverter of UPQC," *IEEE Trans. Power Electron.*, vol. 26, no. 9, pp. 2414–2425, Sep. 2011.

[7] V. Khadkikar, "Enhancing electric power quality using UPQC: A comprehensive overview," *IEEE Trans. Power Electron.*, vol. 27, no. 5, pp. 2284–2297, May 2012.