

Three Phase Symmetrical Multilevel Inverter Design for Renewable Energy Applications

Chintamanu Hussain Basha^{#1}, M Paramesh^{*2}

[#]M. Tech student, GATES Institute of Technology, Gooty, Andhrapradesh, India

^{*}Associate Professor, Dept. of EEE

GATES Institute of Technology, Gooty, Andhrapradesh, India

ABSTRACT

In this paper a new three phase symmetrical multilevel converter for grid connected system using PV source. The renewable energy sources are application of the distributed generation (DG) in the distribution system acquired more attention. The Distribution generation systems are powered by micro sources such as fuel cells, photovoltaic (PV) systems, and batteries. PV distributed system in which the solar source is low dc input voltage interfaced to grid using front-end conversion. Three phase Cascaded H-Bridge Seven level inverter is interfaced with low frequency transformer with multiple PV Source is proposed. Nowadays multilevel inverter (MLI) plays a vital role in the field of power electronics and being widely used in many industrial and commercial applications. Moreover the advantages like high quality power output, low switching losses, low electro-magnetic interference (EMI) and high output voltage made multilevel inverter as a powerful solution in converter topology.

Keywords: Multilevel Inverter, P_v panel, MATLAB

I. INTRODUCTION

Recently, multi-level inverters great attention as a single stage inverter. Although, they have obtained need high number of components, but due to their advantages such as generating output voltage with extremely low distortion factor, low dv/dt, small output filter size, low electromagnetic interface, and low total harmonic distortion, still have great attention. Practically, all of these advantages appear strongly as the number of dc-power sources increased as in the case of renewable energy systems. The general concept of is to utilize isolated dc sources or a bank of series capacitors to produce ac voltage waveforms with higher amplitude and near sinusoidal waveform. There are three conventional types of named as neutral point diode clamped, flying capacitor, and cascaded H-Bridge. Almost all of them are suffering from increased components number per level, and complex control architecture. Among the different topologies for, they can be classified into two main categories: 1) single dc-source inverter such as, and inverters; 2) multi-dc sources inverters such as inverter. While, multi-dc sources inverter is divided

into symmetrical and no symmetrical topologies. principally, no symmetrical topologies produce more voltage levels compared to symmetrical topologies. Almost all of these topologies can be extended for more voltage levels by increasing the number of the primary configuration (basic cell). Many topologies were presented in the last decade focusing on minimizing the basic multilevel topologies drawbacks. The author in presented a topology named multilevel dc link. It consists of a group of basic cells connected in series configuration. Each cell produces or 0 voltage across the connected cells, there is an H-bridge to change the polarity of the synthesized voltage. The required number of active switches for output voltage levels is for the inverters. However, this topology requires increased number of components compared to the conventional topologies, and high voltage stresses. However, in the authors presented a topology named transistor-clamped H-bridge. The primary cell can produce five-levels per pole in the output voltage. However, it suffers also from the increased components counts, requirements of electrolytic capacitors, complex control methodology

II. PHOTOVOLTAIC MODULE

Modelling is the basis for computer simulation of a real system. It is usually based on a theoretical analysis of the various physical processes occurring in the system and of all factors influencing these processes. The most common model used to predict energy production in photovoltaic cell modelling is the single diode circuit model that represents the electrical behaviour of the pn-junction is given in fig 1 Figure shows how photovoltaic system works. The ideal photovoltaic module consists of a single diode. A solar cell is the building block of a solar panel. A photovoltaic module is formed by connecting many solar cells in series and parallel. Considering only a single solar cell; it can be modelled by utilizing a current source, a diode and two resistors. This model is known as a single diode model of solar cell

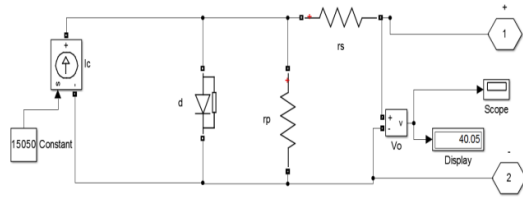

Figure 1: Single diode model of a solar cell
III. PROPOSED MODULAR MLI

A new modular three-phase with reduced components count is proposed and studied in this paper. The suggested three phase symmetrical inverter is shown in Fig2(a). Each arm consists of series connection of basic cells with a series connected switch, for example arm A is consists of one cell connected in series with switch. Adding the common dc voltage source in to each arm forms the pole, creating the pole voltages. In order to obtain the zero state pole voltage another switch is added to the pole, similarly and for pole and. Fig2(b) shows the primary basic cell, where each cell consists of two switches and single dc voltage source. The two switches operate in a complementary fashion. Therefore, each cell can produce two voltage levels: when in ON-STATE, zero voltage is produced across the cell terminals, and when in ON-STATE, volt is applied across the cell terminals. Furthermore, using only one cell per each pole and applying suitable control signals to the, and, three voltage levels per pole are produced. The output pole voltage for cells connected in series configuration is shown in Fig2(c). The proposed topology is a modular type therefore it can be extended to any levels. Equations (1)–(4) provide the relations of the proposed topology as

$$N_{pole} = N_{cell} + 2 \quad (1)$$

$$M_{level} = 2N_{cell} + 3 \quad (2)$$

$$N_{sw} = 3(2N_{cell} + 2) \quad (3)$$

$$N_{ps} = 3N_{cell} + 1 \quad (4)$$

Then for the example of, [based on (2)] which is the pole voltage levels and [based on (3)] which is the output line-to-line voltage levels. Note that the number of output phase voltage levels will be derived to be seven levels in low frequency modulation and nine levels for high frequency modulation.

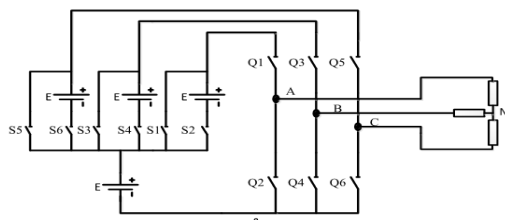

Fig2(a) Proposed three-phase MLI topology

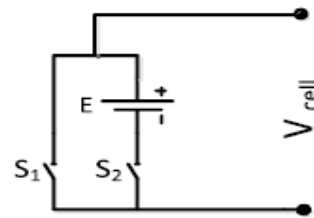

Fig 2(b) Basic cell

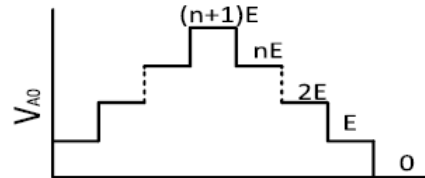

Fig 2(c) Pole voltage waveform for n-ce

IV. MODULATION TECHNIQUES FOR THE PROPOSED MLI

A. Low Frequency Modulation Technique

The low frequency modulation is considered as the basic modulation technique due to its lower switching frequency than the other modulation methods. It causes the switching losses reduced dramatically. In order to investigate the performance of the proposed, three levels per pole by using single basic cell in each pole is used as shown in Fig2. It is simulated via PSIM and MATLAB/SIMULINK software packages. In order to generate the required switching signals for the proposed, a rectified sine waveform has a frequency equals to the output voltage frequency (50 Hz) is compared with a dc voltage signal has an amplitude equal to half of the sine wave amplitude as shown in Fig3. The intersection points between them identify six periods. Four switching signals are constructed from these periods combination in order to generate a sinusoidal output voltage. The control equations for the (S_1, S_2, S_3 and S_4) are given in (5)–(9), respectively. The same scenario is applied to inverter poles and after shifting the basic sinusoidal voltage with $-120^\circ, 120^\circ$, respectively.

Therefore, the required switching signals for the overall three poles can be generated

$$S_1 = P_1 + P_4 \quad (5)$$

$$S_2 = P_2 + P_3 \quad (6)$$

$$Q_1 = P_1 + P_2 + P_3 + P_4 \quad (7)$$

$$Q_2 = P_5 + P_6 \quad (8)$$

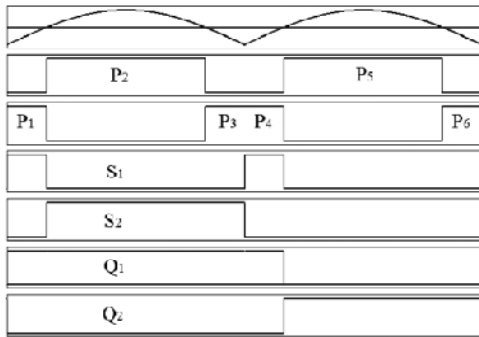

Fig 3 Switching patterns for low frequency modulation technique

B. Sinusoidal Pulse-Width Modulation Technique (SPWM):

The straight way to generate the SPWM signals is to compare a sinusoidal waveform signal with a triangular waveform. The comparison operation will produce the Boolean signals that are required to synthesize the switches control pulses. The SPWM technique is successfully applied for the proposed topology. Two different approaches have been proposed as follows.

1) Scheme I: SPWM Using Single Carrier Signal: This scheme uses one carrier signal centered with the sinusoidal modulation signal (sine waveform), and it has an amplitude equal to peak-to-peak value of the modulation signals as shown in Fig. 4. It worth mentioning that the modulation signal is shifted by dc level equals to $(CR/2)$, where CR is the carrier signal amplitude. The resulted Boolean output from the comparison between the carrier and the modulating signal produces the main pulse signal G_1 . Also the pulse signal GP_1 is generated by comparing the modulating signal with zero value. After logical processing on G_1 and GP_1 , the switching pulses $S_1, S_2, Q_1,$ and Q_2 can be generated as specified in (9)–(12).

$$S_1 = (G_1 \times \overline{GP_1}) + (\overline{G_1} \times GP_1) \quad (9)$$

$$S_2 = (G_1 \times GP_1) \quad (10)$$

$$Q_1 = GP_1 + \{(G_1 \times \overline{GP_1}) + (\overline{G_1} \times GP_1)\} \quad (11)$$

$$Q_2 = \{\overline{GP_1} \times (G_1 \times \overline{GP_1})\} \quad (12)$$

Where \times stands for logic AND, $+$ stands for logic OR, $\overline{}$ stands for invert, and are the signals which will be applied to the gates drive belongs to switches respectively. In order to avoid dc-power sources short circuit operate in a complementary mode with dead time.

2) Scheme II: SPWM Using Two Carrier Signals: This scheme compares single modulating signal with two identical and shifted in level carrier signals. Both of them have amplitude equal the modulating signal peak. In addition, the carrier signals are shifted by a dc offset equals to the carrier signal amplitude as shown in Fig. 5.

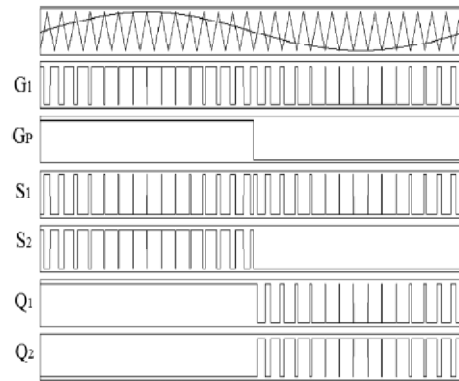
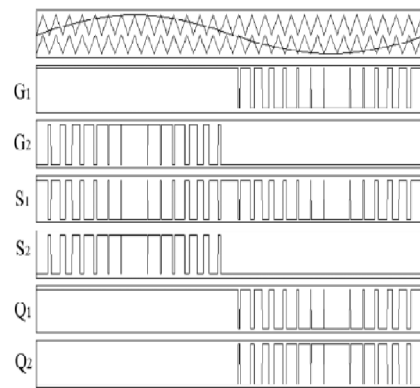

Fig. 4 Switching patterns of the proposed MLI for scheme I



Using the same procedure followed in scheme I, scheme II can be executed. However, due to using two carrier signals, there are two Boolean signals named and resulted from the comparison. By Carrying out several logical operations on these two signals as given in (13)–(16), the required control pulses for can be obtained

$$S_1 = (G_1 \times \overline{G_2}) \quad (13)$$

$$S_2 = G_2 \quad (14)$$

$$Q_1 = \overline{G_2} \times (G_1 \times \overline{G_2}) \quad (15)$$

$$Q_2 = \overline{G_2} \times (G_1 \times \overline{G_2}) \quad (16)$$

IV. SIMULATION RESULTS

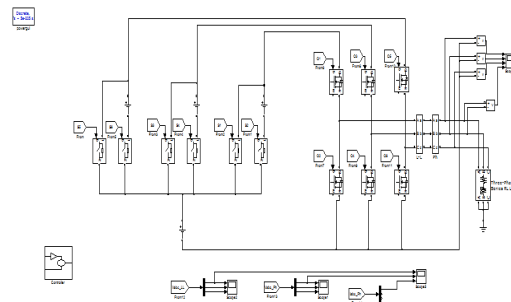

Fig. 6 SIMULINK MODEL of proposed system

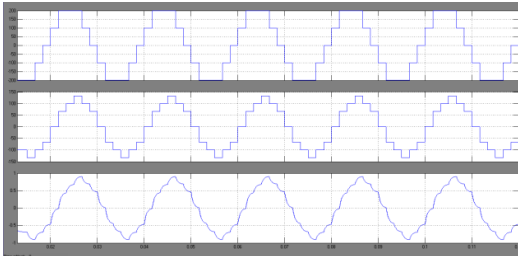

Fig. 7 line to line, phase voltages and phase current with low frequency modulation

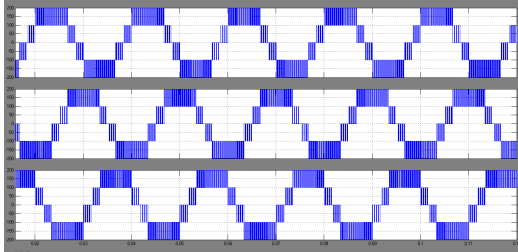

Fig. 8 line to line voltages with SPWM modulation technique

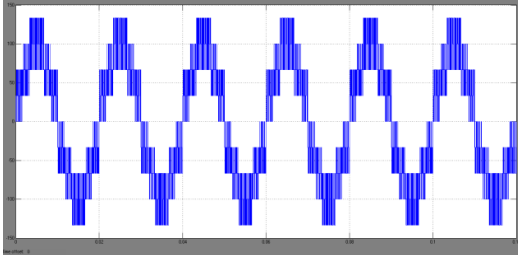

Fig. 9 phase voltages with SPWM modulation technique

V. CONCLUSION

To have sustainable growth and social progress, it is necessary to meet the energy need by utilizing the renewable energy resources like wind, biomass, hydro, co-generation, etc. In sustainable energy system, energy conservation and the use of renewable source are the key paradigm. So, these

new technologies of semiconductor are more suited to high power applications and they enable the design of multilevel inverters. Compared to typical PWM switching schemes, multilevel fundamental switching will lead to lower switching losses. As a result, using the multilevel fundamental frequency switching scheme will lead to increased efficiency.

REFERENCES

- [1] S. J. Park, F. S. Kang, M. H. Lee, and C. U. Kim, "A new single-phase five-level PWM inverter employing a deadbeat control scheme," *IEEE Trans. Power Electron.*, vol. 18, no. 3, pp. 831–843, May 2003.
- [2] V. G. Agelidis, D. M. Baker, W. B. Lawrance, and C. V. Nayar, "A multilevel PWM inverter topology for photovoltaic applications," in *Proc. Int. Symp. Ind. Electron.*, Jul. 1997, vol. 2, pp. 589–594.
- [3] G. J. Su, "Multilevel DC-link inverter," *IEEE Trans. Ind. Appl.*, vol. 41, no. 3, pp. 848–854, May–Jun. 2005.
- [4] M. Calais, L. J. Borle, and V. G. Agelidis, "Analysis of multicarrier PWM methods for a single-phase five level inverter," in *Proc. Power Electron. Specialists Conf.*, 2001, vol. 3, pp. 1351–1356.
- [5] C. T. Pan, C. M. Lai, and Y. L. Juan, "Output current ripple-free PWM inverters," *IEEE Trans. Circuits Syst. II, Exp. Briefs.*, vol. 57, no. 10, pp. 823–827, Oct. 2010.
- [6] T. C. Neugebauer, D. J. Perreault, J. H. Lang, and C. Livermore, "A six-phase multilevel inverter for MEMS electrostatic induction micromotors," *IEEE Trans. Circuits Syst. II, Exp. Briefs.*, vol. 51, no. 2, pp. 49–56, Feb. 2004.
- [7] A. Nabae, I. Takahashi, and H. Akagi, "A new neutral-point-clamped PWM inverter," *IEEE Trans. Ind. Appl.*, vol. IA-17, no. 5, pp. 518–523, Sep. 1981.
- [8] M. F. Escalante, J. C. Vannier, and A. Arzandé, "Flying capacitor multilevel inverters and DTC motor drive applications," *IEEE Trans. Ind. Electron.*, vol. 49, no. 4, pp. 809–815, Aug. 2002.
- [9] M. Malinowski, K. Gopakumar, J. Rodriguez, and M. A. Pérez, "A survey on cascaded multilevel inverters," *IEEE Trans. Ind. Electron.*, vol. 57, no. 7, pp. 2197–2206, Jul. 2010.
- [10] M. A. Pérez, S. Bernet, J. Rodriguez, S. Kouro, and R. Lizana, "Circuit topologies, modeling, control schemes, and applications of modular multilevel converters," *IEEE Trans. Power Electron.*, vol. 30, no. 1, pp. 4–17, Jan. 2015.