

A Cascaded H-Bridge Inverter For Three Phase Connected Photo Voltaic System

B. Srinivas¹ Dr.Samalla Krishna² Mr.S.Srikanth³

¹M. Tech Student Deptt of of Electrical & Electronics Engg. Tudi Ram Reddy Institute of Technology&Sciences, Hyderabad. Banothsrinivaaas93@gmail.com

² Professors, & Principal. Tudi Ram Reddy Institute of Technology&Sciences, Hyderabad. Krishna.oume@gmail.com

³ Assistant Professor, Department of Electrical & Electronics Engg. Tudi Ram Reddy Institute of Technology & Sciences, Hyderabad. Srikanth674@gmail.com

Abstract— This Project Presents Distributed MPPT Based Modular Cascaded H-Bridge Multilevel Inverter. The Modular Cascaded Multilevel Topology Helps To Improve The Efficiency And Flexibility Of PV Systems. The SPWM technique based PWM inverter is help full in making the switching pulse with better output. A new modulation method called trapezoidal triangular multi carrier (TTMC) SPWM is implemented and compared with other methods. This new modulation method gives advantages in multilevel inverter to minimize the percentage of total harmonic distortion (THD) and to increase the output voltage. To realize better utilization of PV modules and maximize the solar energy extraction, a Distributed Maximum Power Point Tracking control scheme is applied to the three phase multilevel inverters. The power generated by the inverter is delivered to power network, so the utility grid. The proposed system is simulated using MATLAB.

Index Terms—Cascaded multilevel inverter, distributed maximum power point(MPP) tracking(MPPT), modular, modulation compensation, photovoltaic(PV)

1. INTRODUCTION

Due to the shortage of fossil fuels and environmental problems caused by conventional power generation, renewable energy, particularly solar energy, has become very popular. Solar-electric-energy demand has grown consistently by 20%-25% per annum over the past 20 years. And the growth is mostly in grid-connected applications. With the extraordinary market growth in grid-connected photovoltaic (PV) systems, there are increasing interests in grid-connected PV configurations.

Cascaded inverters consist of several converters connected in series; thus, the high power and/or high voltage from the combination of the multiple modules would favor this topology in medium and large grid -connected PV systems. There are two types of cascaded inverters. Each PV module has its own dc/dc converter, and the modules with their associated converters are still connected in series to create a high dc voltage, which is provided to a simplified dc/ac inverter. This approach combines aspects of string inverters and ac -module inverters and offers the advantages of individual module maximum power point (MPP) tracking (MPPT), but it is less costly and more efficient than ac-module inverters.

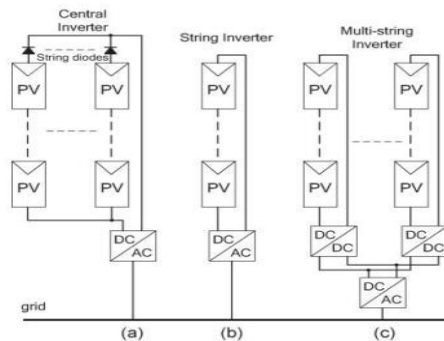

Fig. 1. Configurations of PV systems. (a) Central inverter. (b) String inverter. (c) Multilevel inverter. (d) AC - module inverter. (e) Cascaded dc/dc converter. (f) Cascaded dc/dc converter. (f) Cascaded dc/ac inverter.

The modular cascaded H-bridge multilevel inverter, which requires an isolated dc source for each H-bridge, is one dc/ac cascaded inverter topology. The separate dc links in the multilevel inverter make independent voltage control possible. As a result, individual MPPT control in each PV module can be achieved, and the energy harvested from PV panels can be maximized. Meanwhile, the modularity and low cost of multilevel converters would position them as a prime candidate for the next generation of efficient, robust, and reliable grid-connected solar power electronics.

A modular cascaded H-bridge multilevel inverter topology for three-phase grid connected PV systems is presented in this paper. The panel mismatches issues are addressed to show the necessity of individual MPPT control, and a control scheme with distributed MPPT control is then proposed. The distributed MPPT control scheme can be applied to three-phase systems.

2. SYSTEM DESCRIPTION

In the proposed system, three phase five level inverter was developed from the cascaded H-Bridge Multilevel Inverter it uses four bidirectional switches and produces five voltage levels. The modular cascaded multilevel topology helps to improve the efficiency and flexibility of PV systems. The SPWM technique based PWM inverter help full in making the switching pulse with better output. A new modulation method called trapezoidal triangular multi carrier (TTMC) SPWM is implemented and compared with other methods. This new modulation method gives advantages in multilevel inverter to minimize the percentage of total harmonic distortion (THD) and to increase the output voltage. To realize better utilization of PV modules and maximize the solar energy extraction, a Distributed Maximum Power Point Tracking control scheme is applied to the three phase multilevel inverters. The power generated by the inverter is delivered to power network, so the utility grid, rather than a load.

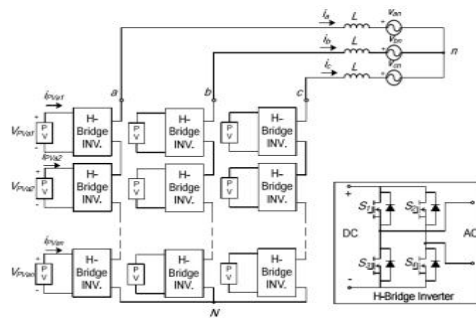

Fig. 2. Topology of the modular cascaded H-bridge multilevel inverter for grid-connected PV systems.

3. CONTROL SCHEME

A. Distributed MPPT Control

In order to eliminate the adverse effect of the mismatches and increase the efficiency of the PV system, the PV modules need to operate at different voltages to improve the utilization per PV module.

The separate dc links in the cascaded H-bridge multilevel inverter make independent voltage control possible. To realize individual MPPT control in each PV module, the control scheme proposed.

The distributed MPPT control of the three-phase cascaded H-bridge inverter is shown. In each H-bridge module, an MPPT controller is added to generate the dc-link voltage reference, and the sum of all errors is controlled through a total voltage controller that determines the current reference I_{dref} . The reactive current reference I_{qref} can be set to zero, or if reactive current calculator. The synchronous reference frame phase-locked loop (PLL) has been used to find the phase angle of the grid voltage. As a classic control scheme in three-phase systems, the grid currents in abc coordinates are converted to dq coordinates and regulated through proportional-integral (PI) coordinates, which is then converted back to three phases.

The distributed MPPT control scheme for the single-phase system is nearly same. The total voltage controller gives the magnitude of the active current reference, and a PLL provides the frequency and phase angle of the active current reference. The current loop then gives the modulation index.

To make each PV module operate at its own MPP, take phase a as an example; the voltages $vdca2$ to $vdcan$ are controlled individually through $n - 1$ loops. Each voltage controller gives the modulation index proportion of one H-bridge module in phase a . after multiplied by the modulation index of phase a , $n - 1$ modulation indices can be obtained. Also, the modulation index for the first H-bridge can be obtained by subtraction. The control schemes in phases b and c are almost the same. The only difference is that all dc-link voltages are regulated through PI controllers, and n modulation index proportions are obtained for each phase.

A phase-shifted sinusoidal pulse width modulation switching scheme is then applied to control the switching devices of each H-bridge.

It can be seen that there is one H-bridge module out of N modules whose modulation index is obtained by subtraction. For single-phase systems, $N=n$, and for three-phase systems, $N=3n$, where n is the number of H-bridge modules per phase. The reason is that N H-bridges, and one is the total voltage loop, which gives the current reference. So, only $N - 1$ modulation index can be determined by the last $N - 1$ voltage loops, and one modulation index has to be obtained by subtraction.

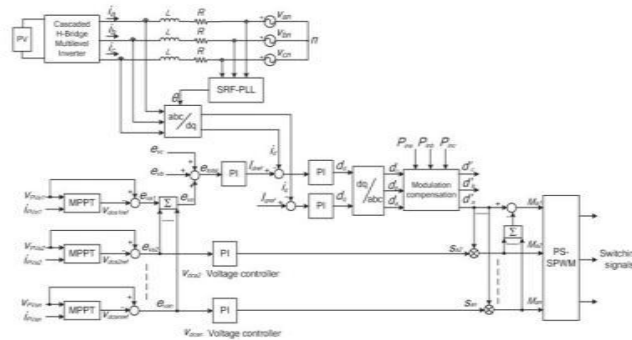

Fig. 3. Control scheme for three phase modular cascaded H-bridge multilevel PV inverter.

Many MPPT methods have been developed and implemented. The incremental conductance method has been used in this paper. It lends itself well to digital control, which can easily keep track of previous values of voltage and current and make all decisions.

B. Modulation compensation

As mentioned earlier, a PV mismatch may cause more problems to a three-phase modular cascaded H-bridge multi-level inverter. With the individual MPPT control in each H-bridge module, the input solar power of each phase would be different, which introduces unbalanced current to the grid. To solve the issue, a zero sequence voltage can be imposed upon the phase legs in order to affect the current flowing into each phase. If the updated inverter output phase voltage is proportional to the unbalanced power, the current will be balanced.

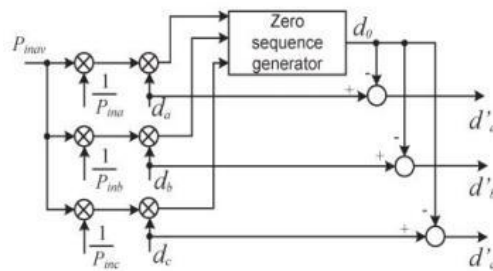

Fig. 4. Modulation Compensation Scheme

Thus, the modulation compensation block, as shown in Fig. 4, is added to the control system of three-phase modular cascaded multilevel PV inverters. The key is how to update the modulation index of each phase without increasing the complexity of the control system. First, the unbalanced power is weighted by ratio r_j , which is calculated as

$$r_j = \frac{P_{inav}}{P_{inj}}$$

Where P_{inj} is the input power of phase j ($j= a,b,c$), and P_{inav} is the average input power.

Then, the injected zero sequence modulation index can be generated as

$$d_0 = \frac{1}{2} [\min(r_a \cdot d_a, r_b \cdot d_b, r_c \cdot d_c) + \max(r_a \cdot d_a, r_b \cdot d_b, r_c \cdot d_c)]$$
 where d_j is the modulation index of phase j ($j=a,b,c$) and is determined by the current loop controller.

The modulation index of each phase is updated by

$$d'_j = d_j - d_0.$$

Only simple calculations are needed in the scheme, which will not increase the complexity of the control system. An example is presented to show the modulation compensation scheme more clearly. Assume that the input power of each phase is unequal

$$P_{ina} = 0.8 \quad P_{inb} = 1 \quad P_{inc} = 1.$$

By injecting a zero sequence modulation index at $t=1$ s, the balanced modulation index will be obtained. It can be seen that, with the compensation, the updated modulation index is unbalanced proportional to the power, which means that the output voltage (V_jN) of the three-phase inverter is unbalanced, but this produces the desired balanced grid current.

4. SIMULATION RESULTS

The proposed configuration has been simulated using MATLAB/Simulink for the MPPT Based Modular Cascaded H-Bridge Multilevel Inverter. The gating signals for the inverter are generated by using multicarrier modulation technique. As mentioned previously, the dc link of each H-bridge module is fed by one PV panel. With the distributed MPPT control, the dc-link voltage of each H-bridge can be controlled independently. In other words, the connected PV panel of each H-bridge can be operated at its own MPP voltage and will not be influenced by the panels connected to other H-bridges. Thus, more solar energy can be extracted, and the efficiency of the overall PV system will be increased.

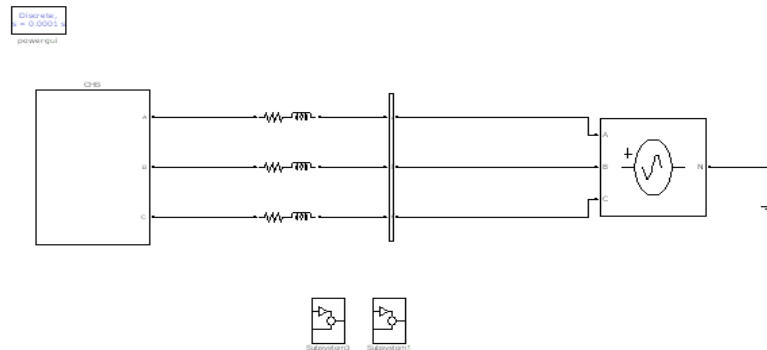

Fig.5 MATLAB/SIMULATION circuit diagram of modular cascaded H-bridge multilevel inverter for grid-connected PV systems.

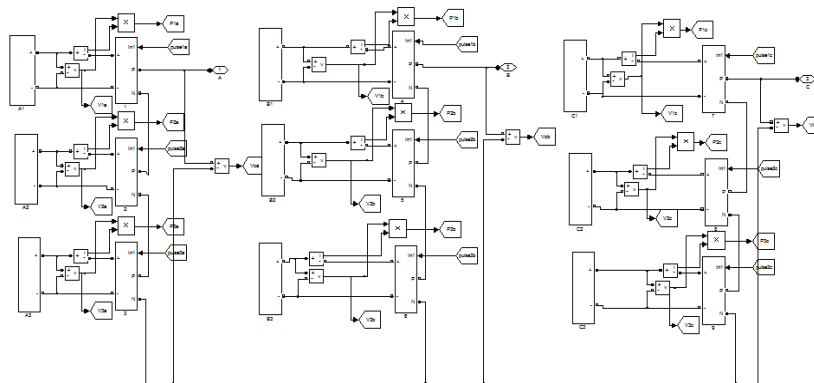

Fig 6 Subsystem of pv with cascaded H-bridge multilevel inverter

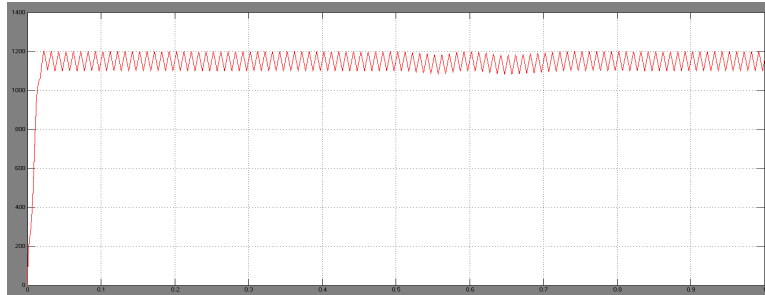

Fig 7 DC-link voltages of phase b with distributed MPPT

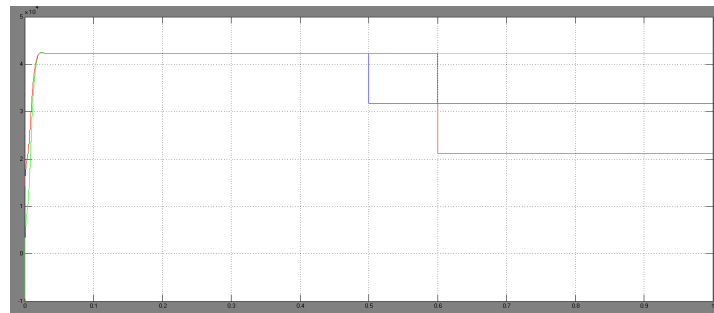

Fig 8 Power extracted from PV panels with distributed MPPT

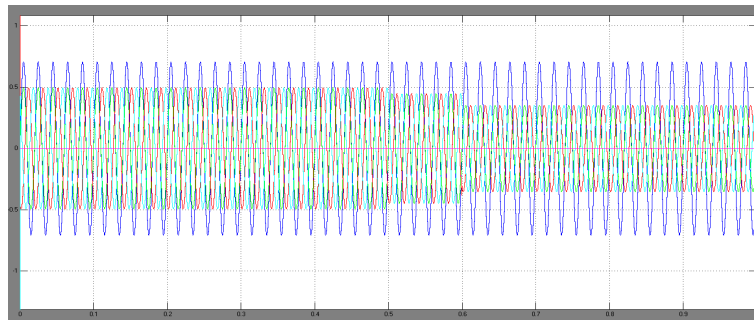

Fig 9 Three-phase grid current waveforms with modulation compensation.

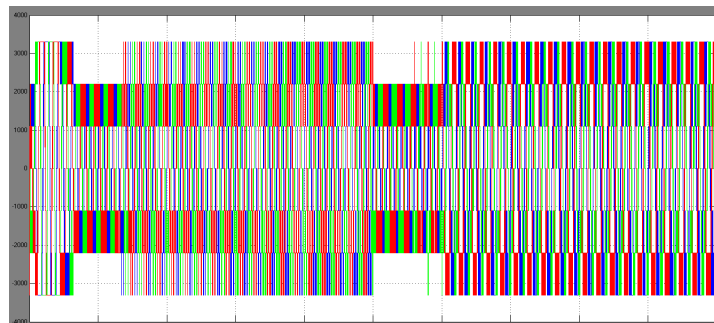

Fig 9 Three-phase inverter output voltage waveforms with modulation compensation

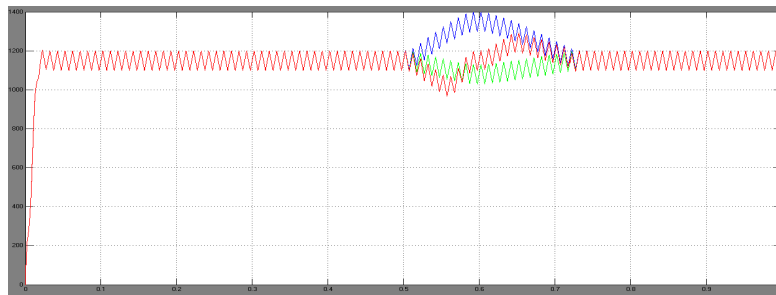

Fig 10 DC-link voltages of phase a with distributed MPPT

CONCLUSION

This Paper has proposed Distributed MPPT based cascaded H-bridge multilevel inverter. The multilevel inverter topology will help to improve the utilization of connected PV modules if the voltages of the separate dc links are controlled independently. Thus a distributed MPPT control scheme for three-phase PV systems has been applied to increase the overall efficiency of PV systems. For the three-phase grid-connected PV system, PV mismatches may introduce unbalanced supplied power, resulting in unbalanced injected grid current. A modulation compensation scheme, which will not increase the complexity of the control system or cause extra power loss, is added to balance the grid current. A modular three-phase five-level cascaded H-bridge inverter has been built in the laboratory and tested with PV panels under different partial shading conditions. With the proposed control scheme, each PV module can be operated at its own MPP to maximize the solar energy extraction, and the three-phase grid current is balanced even with the unbalanced supplied solar power.

REFERENCES

- [1] J.Rodriguez, J. S. Lai, and F. Z. Peng, "Multilevel inverters: A survey of topologies, controls, and applications," *IEEE Trans. Ind. Electron.*, vol. 49, no. 4, pp. 724–738, Aug. 2002.
- [2] S. B. Kjaer, J. K. Pedersen, and F. Blaabjerg, "A review of single-phase grid connected inverters for photovoltaic modules," *IEEE Trans. Ind. Appl.*, vol. 41, no. 5, pp. 1292–1306, Sep./Oct. 2005.
- [3] H. Ertl, J. Kolar, and F. Zach, "A novel multicell DC–AC converter for applications in renewable energy systems," *IEEE Trans. Ind. Electron.*, vol. 49, no. 5, pp. 1048–1057, Oct. 2002.
- [4] G. R. Walker and P. C. Sernia, "Cascaded DC–DC converter connection of photovoltaic modules," *IEEE Trans. Power Electron.*, vol. 19, no. 4, pp. 1130–1139, Jul. 2004.
- [5] E. Roman, R. Alonso, P. Ibanez, S. Elorduizapatarietxe, and D. Goitia, "Intelligent PV module for grid-connected PV systems," *IEEE Trans. Ind. Electron.*, vol. 53, no. 4, pp. 1066–1073, Jun. 2006.
- [7] Y. Zhou, L. Liu, and H. Li, "A high-performance photovoltaic module-integrated converter (MIC) based on cascaded quasi-Z-source inverters (qZSI) using eGaN FETs," *IEEE Trans. Power Electron.*, vol. 28, no. 6, pp. 2727–2738, Jun. 2013.
- [8] A. Dell'Aquila, M. Liserre, V. Monopoli, and P. Rotondo, "Overview of PI-based solutions for the control of DC buses of a single-phase H-bridge multilevel active rectifier," *IEEE Trans. Ind. Appl.*, vol. 44, no. 3, pp. 857–866, May/Jun. 2008.
- [9] S. Selvakumar, Dr. S. Ravi, Adaptive Modulation IN Reconfigurable Platform Journal of Theoretical and Applied Information Technology.

Vol 68, PP 108-114, Oct 2014.

[10] S. Selvakumar, Dr.S.Ravi, DPSK and QAM Modulation Detection analyzed with BER Estimation IEEE International Conference on Current Trends in Engineering and Technology, July 2014.

AUTHOR'S PROFILE



DR. SAMALLA KRISHNA so far has successfully guided many post graduate students in the fields of Signal and Image Processing, Neural Networks and Pattern Recognition while several other students are being supervised by him in a wide variety of other fields like DSP, Medical Image Processing and Object Recognition in addition to this he supervised many electrical and other disciplinary engineering students. He served as an academic supervisor to more than 300 Bachelor Degree dissertations towards the award of Undergraduate Degree, and He has published more than 35 research papers in reputed International Journals. He shared his research experience more than many podiums like conferences, workshops, seminars and symposia. And currently he is working as a professor in TUDI Group of institutions, Hyderabad. He has 12 years of experience in the teaching and research field. His many research articles are cited by scholars and research institutions.

MR. S.SRIKANTH is a Post Graduated from the field of Electrical Engineering. He has 3 years of teaching experiences for Graduate and Post Graduate engineering courses. He has published her research work many International Journals and conferences. He guided several engineering students for their academic projects.



BANOTH SRINIVAS, PG Student of Electrical, Tudi Ram Reddy Institute of Technology & Sciences, Telangana, India. He did bachelor degree from Vidya Bharathi Institute of Technology, Pembarthy, Telangana, India

