

Upqc with Islanding and Grid Connection for Micro grid Applications

SHAIK ASIF¹ Y. SUMANTH²

¹PG Scholar, Dept of EEE(EPS), Brilliant Group of Technical Institutions.Hyderabad,, TS, India.

² Associate Professor, Dept of EEE, Brilliant Group of Technical Institutions.Hyderabad, TS, India.

Abstract- The micro-grids are interconnection of renewable resources available at distribution side .Micro -grids can be operated in three different ways grid connected mode, autonomous mode and micro generation mode .The battery system is connected in DC link for supplying real power in the micro-grid .Quality of power supply has become an important issue with the increasing demand of DG system either connected to the conventional grid, smart grid or micro grid. Most of the pollution issues created in power systems are due to the non-linear characteristics and fast switching of power electronic devices which introduce harmonic in the line voltage and current .To eliminate the power quality issues from the distribution system it is essential to improve the reliability of the system. The Unified Power Quality Conditioner (UPQC) is used to to improve the real power by improving the quality of supply during the interconnected and islanded mode. Here UPQC is connected with micro-grid to improve the power quality and reduce the oscillations when the mode of the connection changes .The new control strategy is used for the integration and control of Unified Power Quality Conditioner in distribution generation based micro-grid system.

Index Terms- Unified Power Quality Compensator, Micro grid, Power Quality, Islanding Detection, Synchronous reconnection, Distribution Generation.

I. INTRODUCTION

The challenging issues of a successful placement and integration of unified power quality conditioner (UPQC) in a distributed generation (DG)-based grid connected microgrid (μ G) system are

1) Control complexity for active power transfer; 2) ability to compensate non-active power during the islanded mode; and 3) difficulty in the capacity embellishment in a modular way [1]. For a smooth power transfer between the grid-connected system and islanded mode, various operational changes are presented, such as switching between the current and voltage control mode, robustness against the islanding detection and reconnection delays and method and so on [2], [4]. Clearly, these further increase the control complexity of the microgrid systems. To extend the operational flexibility and to improve the power quality in grid connected microgrid systems, a new control strategy placement and integration technique of UPQC have been proposed in [3], which is termed as UPQC μ G. In the UPQC μ G integrated distributed system, micro grid (with storage) and shunt part of the UPQC μ G are placed at the Point of common coupling. The series of the UPQC is placed before the Point of common coupling and in series with the grid. DC link is connected to

the storage also, if present.

To maintain the operation in island mode and reconnection through the UPQC, communication process between the UPQC micro grid and micro grid system is mentioned in [3]. In the present work, the control technique of the presented UPQC micro grid in [3] is enhanced by implementing an islanding and novel reconnection technique with reduced number of switches that will ensure smooth operation of the micro grid without interruption. Hence it is termed as UPQC micro grid –IR. The objective of this paper is to study the various types of power quality problems and their effects in distribution generation based grid connected microgrid system, to investigate that the mitigation techniques are suitable for voltage sag/ swell and interruptions in the event of a fault in a distribution generation based grid connected microgrid system. To observe the effect on the characteristic of voltage sag / swell and interruption for the techniques. Construct the micro grid control for all modes of operations, with more emphasis on: voltage sag / swell, harmonic and reactive power compensation and active power transfer to the load in the interconnected mode and how they can be mitigated with the use of the Unified Power Quality Conditioner (UPQC), which are also called custom power devices.

In this paper Different power quality issues their causes and consequences and solution have been discussed with islanding and reconnection technique. The modelling of series APF, shunt APF, PSD, Islanding detection and Reconnection and the UPQC has been carried out .Using hysteresis band controller the model has been developed. From the simulation results UPQC improves the power quality of power system during sag, swell and interruption condition with islanding condition .The THD of the source current and load current is reduced. The Methodology of the proposed system is described in section II. Based on the working principle and methodology, some of the controller design deals with the section III with islanding detection and reconnection techniques in detail. Section IV shows the performance study result.

II. METHODOLOGY

The Integration technique of the proposed UPQC micro grid –IR to a grid connected and DG integrated micro grid system is presented in Fig 1(a). S1 and S2 are the breaker switches that are used to island and reconnect the micro grid system to the grid as directed by the secondary control of the UPQC micro grid –IR. The working principle during the interconnected and islanded mode for this configuration is shown in the Fig 1(b, c).

A. Interconnected mode

In this mode, as shown in Fig 1(b);

1. The DG source delivers only the fundamental active power to the grid, storage and load.
2. The APFsh compensates the reactive power and harmonic power (QH) of the non-linear load to keep the THD at the PCC within the IEEE standard limit.
3. Voltagesagswell/interruption can be compensated by the active power from the grid/storage through the APFse. DG converter does not sense any kind of voltage disturbance at the PCC and hence remains connected in any condition.
4. If the voltage interruption/black out occurs, UPQC sends a signal within a pre-set time to the DG converter to be islanded.

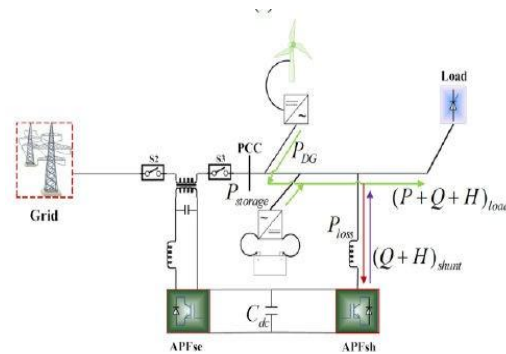

Fig 1(c)

B. Islanded mode

In this case, as shown in Fig 1(c);

1. The APFse is disconnected during the grid failure and DG converter remains connected to maintain the voltage at PCC.
2. The APFsh still compensates the non-active power of the non-linear load to maintain undistorted current at PCC for other linear loads.
3. Therefore, DG converter (with storage) delivers only the active power and hence does not need to be disconnected from the system.
4. The APFse is reconnected once the grid power is available.

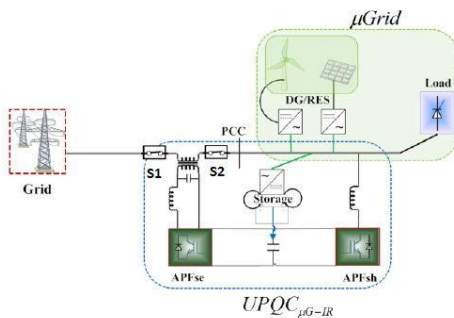

Fig 1 (a)

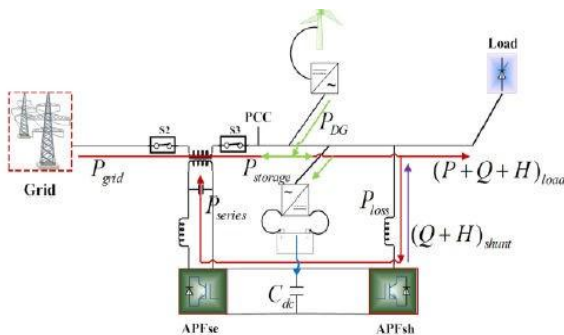

Fig 1(b)

Fig 1 (a) Shows Integration Technique of UPQC_{μG-IR}, Fig 1(b) Working principle in Interconnected Mode, Fig 1 (c) Working Principle in Islanded Mode

III. CONTROLLER DESIGN

The block diagram of the proposed UPQC microgrid-IR Controller is shown in Fig 2. It has the same basic functions as the UPQC controller except for the additional islanding detection and reconnection techniques and capabilities. A signals transfer between the proposed UPQC_{μG-IR} and the micro grid is also required for the seamless operation. These signals generation are based on the voltage sag/swell/interrupt/ failure of supply conditions. This has been performed in secondary control (LEVEL-2) of the hierarchical control [6]. Primary control deals with the Level 1 of the UPQC to perform their basic functions in the interconnected and the islanded mode [7]. The overall integration technique and control strategy are used to improve the quality of supply during interconnected and islanded modes. This technique involves detecting islanding and reconnection that secures the DG converter remains connected and supply active power to the load. This reduces the control intricacy of the converter as well as the power failure possibility in the islanded mode. The main Controllers of the proposed system are

- Series part (APFse) Control,
- Shunt part (APFsh) Control,
- Intelligent Islanding Detection (IsD) and
- Synchronization and Reconnection (SynRec).

As the Islanding detection and Synchronous Reconnection features are new in UPQC therefore, these have been presented in details.

A. Intelligent Islanding Detection (IsD)

Considering the future trends towards the smart-grid and micro grid operation in connection with the distribution grid, it have a capability of (i) maintaining connection during grid fault condition, (ii) automatically identified and detecting the islanded condition and (iii) reconnecting after the grid fault. These are the most important features of the micro grid system. In that case, the placement of APFse in the proposed integration method of the system plays an important role by improving the operational flexibility of the DG converter in the microgrid system.

In addition to the islanding detection, changing the control strategy from current to voltage control may result in serious voltage problems and it becomes serious when the islanding detection is delayed in the case of hierarchical control. Therefore seamless/smooth voltage transfer control between the grid-

connected and isolated controlled modes is very important to mitigate the voltage transients in transition mode, but these then increase the control complexity of the μ G converters.

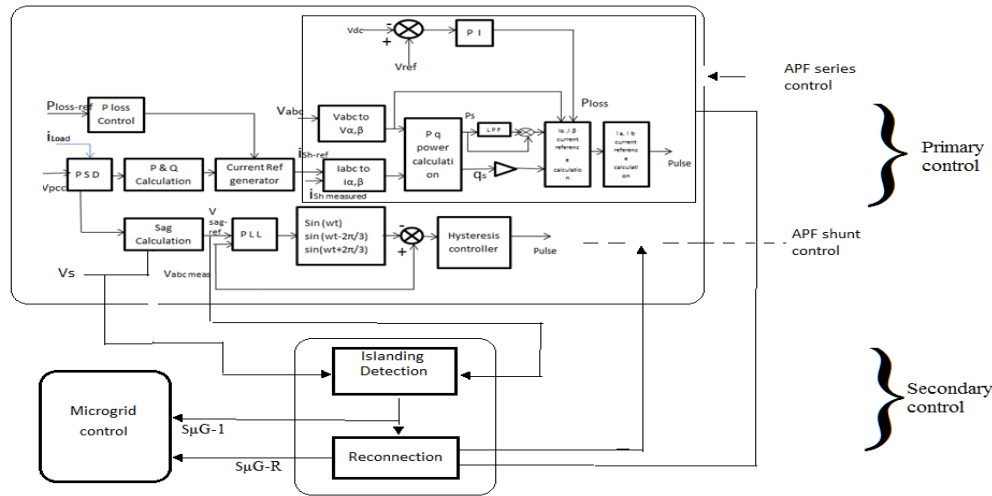

Fig 2: Block diagram of the UPQC μ G-IR –(a) Controller (b) Control algorithm

In the case of power quality problems, it is reported that more than 95% of voltage sags can be compensated by injecting a voltage up to 60% of the nominal voltage, with a maximum duration of 30 cycles. Therefore, based on the islanding detection requirement and sag/swell/interrupt compensation, islanding is detected and a signal $S_{\mu-1}$, as shown in Fig 2(b), signal is also generated in the proposed UPQC microgrid-IR to transfer it to the DG converters. As the series active power filter takes the responsibility for compensating voltage sag/swell/unbalance disturbances. Intelligence islanding detection algorithm in the proposed UPQC microgrid-IR can be simple and quite flexible. On the other hand, it will help to minimize the complexity of islanding detection technique.

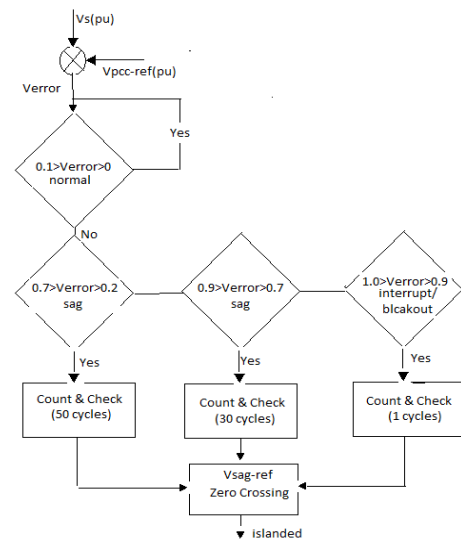

Fig 3: Algorithm for IsD method in UPQC μ G-IR

Fig 3 shows a simple algorithm for IsD method with example that has been used to detect the islanding condition to operate the UPQC in islanded mode. The voltage at the point of common coupling is taken as the reference and it is always in phase with the source and the DG converters, the difference between the $V_{pcc-ref}$ (pu) and V_s (pu) is V_{error} . This V_{error} is then compared with the pre-set values (0.1 to 0.9) and a waiting period (user defined n cycles) .It is used to determine the voltage sag/interrupt/islanding condition. In this example, (i) if is less

than or equal to 0.7, then 70% sag will be compensated for up to 50 cycles; (ii) if is in between 0.7 to 0.9, then compensation will be for 30 cycles; (iii) otherwise ($V_{sag-max}$) it will be interrupt/black out for islanding after 1 cycle.

This type of signal generation method is simple and it can also be adjusted for any time period and condition. Thus this technique can be achieved by introducing the operational flexibility of time and control of voltage sag/swell/interrupt compensation before islanding. As the smooth voltage transfer from grid connected to isolated mode is one of the critical cases in transition periods, the voltage transfer is completed at the zero crossing position of the series active power filter. Therefore, no voltage distortion or fault conditions occur.

B. Synchronization and Reconnection (SynRec)

Once the grid system is restored, the micro grid may be reconnected to the main grid and return to its pre-disturbance

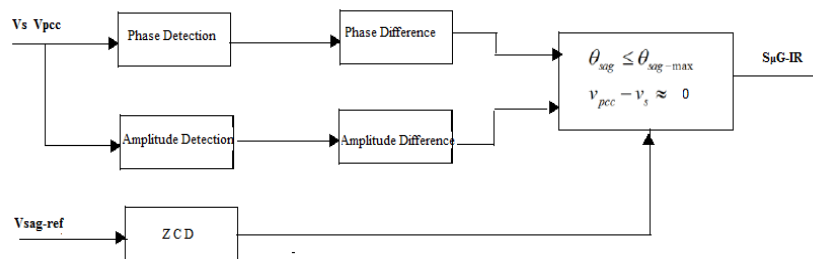

Fig 4 (a) Synchronization and Reconnection method

The relation for the magnitude and phase difference V_{pcc} , V_{sag} and V_{scan} can be obtained. The zero-crossing point of the $V_{sag-ref}$ depending upon the phase. This zero-crossing detection also indicates the point at which the instantaneous voltage difference between the utility and the PCC becomes zero. Detection of this zero-crossing point and activation of the switches S1 and S2, as shown in Fig 1, at the same time are the key control of this reconnection method for a seamless transfer from the off-grid to the on-grid condition as well as changing the controller of the DG inverter from voltage to current control mode.

The reconnection method is shown in Fig 4(b). Conditions for reconnection are set as; (i) assuming the phase difference between the utility grid and DG unit should be within $\theta_{sag-max}$, (ii) the instantaneous value of the two bus voltages becomes equal and (iii) these should occur at the zero crossing condition. Once the utility supply is available after a blackout, a synchronization pulse (generated in reconnection process) is enabled to start synchronization. A simple logic sequence is then created, based on the condition shown in Fig 6(b), to generate the active pulse for S2 and S3 to return the system in the interconnected mode. At the same time $S_{\mu G-IR}$, as shown in Fig 4(b) is also transferred to the μG system for reconnection.

The other advantage is that, IsD and SynRec methods have been carried out as a secondary control in Level 2, i.e. these can also be added in conventional UPQC system as an additional block to convert it to UPQCmicrogrid-IR. It is to be noted that

condition. A smooth or seamless reconnection can be achieved when the difference between the voltage magnitude, phase and frequency of the two buses are minimized or close to zero. The smooth reconnection also depends on the performance and accurate results of the synchronization methods. In case of UPQC micro grid-IR, reconnection is performed by the series APF. Moreover, due to the control of voltage sag/swell by the series APF, this UPQC micro grid-IR has the advantage of reconnection technique even in case of phase difference/jump (up to a some limit) between the utility voltage and at the Point of common coupling. This absolutely increases the operational flexibility of the microgrid system with high power quality. The phase difference limit depends on the rating of the series APF and the level of $V_{sag-max}$ required for compensation. Assuming that the possible $V_{sag-max} = V_s = V_{pcc}$, the $\theta_{sag-max}$ can be; $\theta_{sag-max} = \cos [(\theta_s - \theta_{pcc})]$ inverse = 20 degree

the proposed UPQCmicrogrid-IR will be helpful to meet the required advanced grid integration features as mentioned.

IV. RESULTS AND DISCUSSIONS

The simulation results of SHU APF, SER APF, islanding & reconnection technique for microgrid with the unified power quality conditioner to evaluate the offered control stratagem. The simulation models have been established by MATLAB/SIMULINK environment.

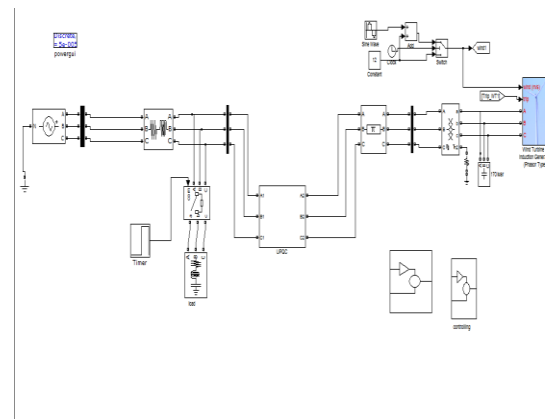

Fig :5MATLAB/SIMULINK diagram of proposed system

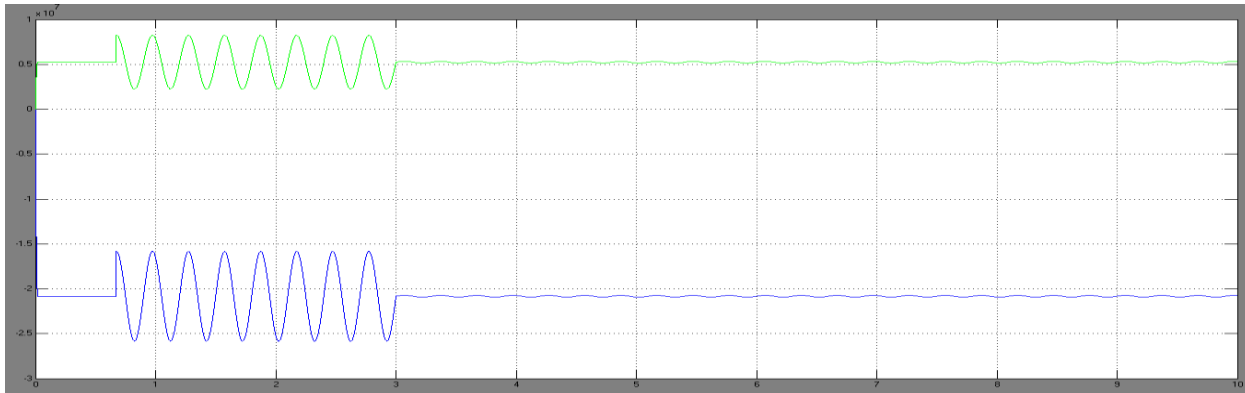

Fig 5 (a) Grid active power and Reactive power

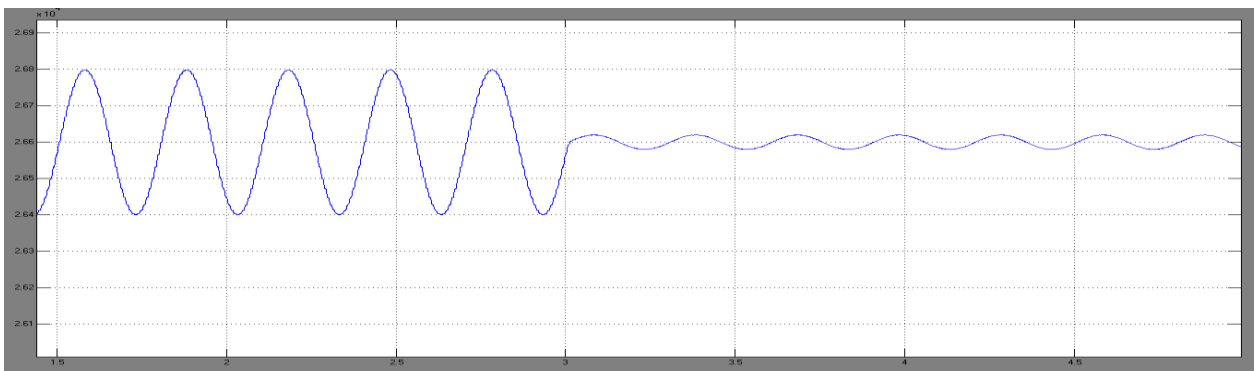

Fig 5 (b) Source Voltage

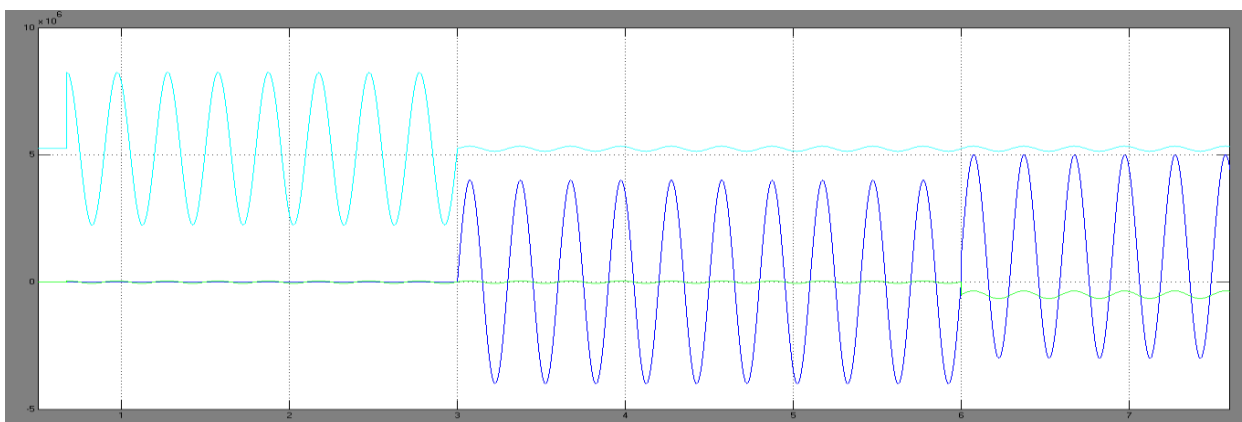

Fig 6: Active and Reactive powers of series APF, shunt APF

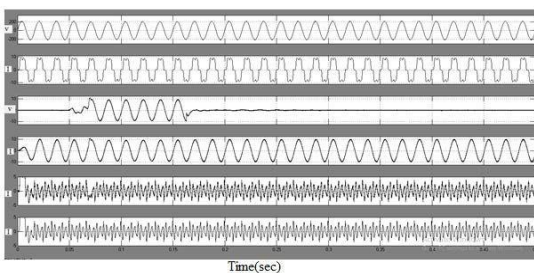

Fig 6.1: Simulation results of UPQC a) load voltage b) load current c) series injected voltage d)Grid Current e)Injected Current

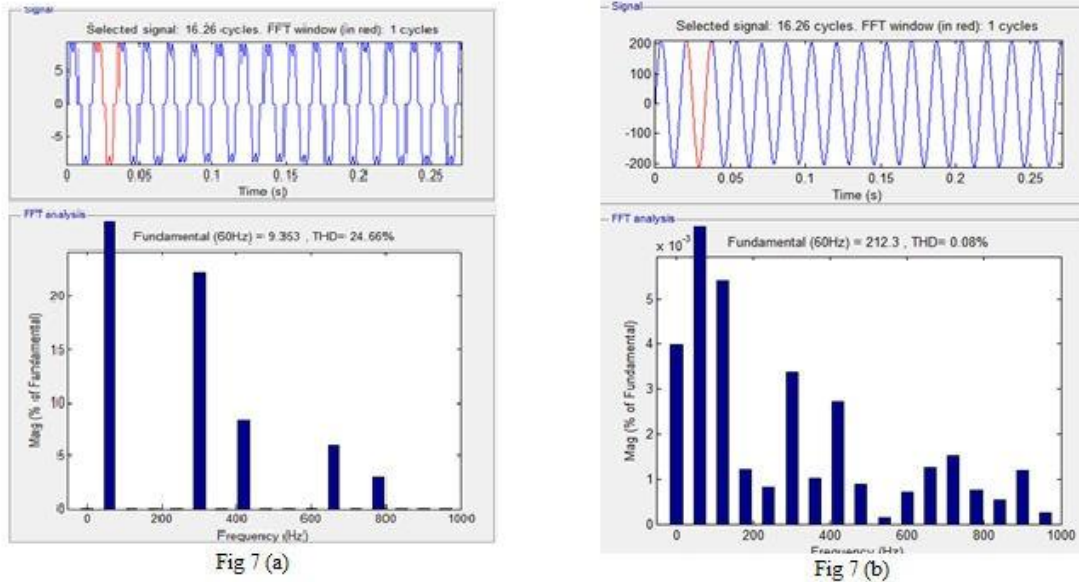

Fig 7: Total Harmonic Distortion a) Load current, b)Source current

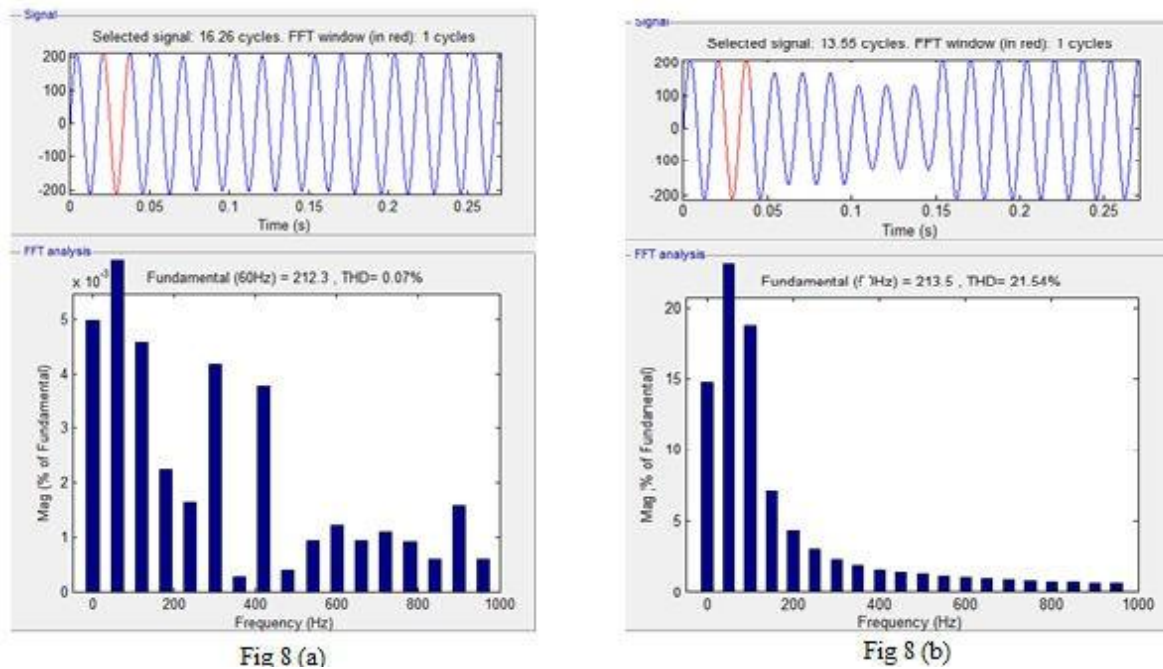

Fig 8: Total Harmonic Distortion: a)Load voltage (b), Source Voltage

V. CONCLUSION

This paper describes a control and integration of islanding and reconnection technique of the proposed UPQC microgrid-IR in the grid connected micro grid condition. The performance with off-line simulation has been obtained. The results show that the UPQC microgrid-IR can compensate the voltage and current disturbance at the Point of Common Coupling during the interconnected mode. In islanded mode, the DG converters only

supply the active power. Therefore, the DG converters need not to be disconnected or change their control strategy to keep the MicroGrid operating in any time with any condition.

REFERENCES

- [1] S K Khadem, M Basu, M F Conlon, UPQC for Power Quality Improvement in DG Integrated Smart Grid Network – A Review, Int Journal of Emerging Electric Power Systems, Vol. 13(1), 2012, Art 3
- [2] X. Yu, A.M. Khambadkone, H. Wang, S. Terence, Control of Parallel-Connected Power Converters for Low-Voltage Microgrid—Part I: A Hybrid

Control Architecture, IEEE Trans

- [3] S K Khadem, M. Basu, M.F. Conlon, A new placement and integration method of UPQC to improve the power quality in DG network, Universities Power Engineering Conference
- [4] A Kahrobaeian, Y Mohamed, Interactive distributed generation interface for flexible microgrid operation in smart distribution systems, IEEE Trans Sustainable Energy, vol.3(2), pp.295-305, 2012 Power Electronics , vol.25 (12), 2010, pp.2962-2970 , UPEC, Vol.1, Sept 2013.

AUTHOR'S PROFILE



SHAIK ASIF Received his B.Tech(EEE) degree from Muffakham Jah Engineering College, Osmania University And M.Tech (Electrical Power Systems) from BRIG ,Hyderabad,TS,India.



Y. SUMANTH Received his B.Tech(EEE) degree from JNTU Kakinada in 2012 and M.Tech (Power Systems) from Amity University, Noida in 2015. Currently he is working as Assistant Professor in Dept. of EEE, BGTI. He has published few papers in International Journals and Conferences. His areas of interest are Distributed Generation & Micro Grids, Energy Storage Systems and Power System Operation & Planning.