

An Observer-Based Optimal Voltage Control Scheme for Three-Phase Three Level UPS Systems

Mr.Satish Bandaru¹(Assistant Professors& HOD, Dept Of EEE, MITS, Kodad, Telangana, India.)
 Mr.Vankudothhathiram²(Assistant Professors, Dept Of EEE, MITS, Kodad, Telangana, India.)
 Mr.Srikanth Borra³(PG Scholor, Dept Of EEE , MITS, Kodad, Telangana, India.)

Abstract:

Uninterrupted Power Supply (UPS) system supplies required power in case of utility power failures. UPS system has got significant importance in the field of industrial electronics due to increase in technology of power electronic devices. This paper proposes a Neutral Point Clamped (NPC) inverter with simple Sinusoidal Pulse Width Modulation Technique (SPWM), which is well suitable for inverter control. The proposed system would be subjected to fast transient response, small steady state error and low harmonic distortion test under different load conditions. Finally, the comparative results for the proposed scheme and the observer based voltage control scheme are presented to show that the proposed scheme achieves better performance. The results are tested and verified through MATLAB/Simulink. The proposed methodology reduces the total cost, complexity and THD.

Keywords: Inverter, Uninterrupted Power Supply (UPS), Neutral Point Clamped (NPC) Inverter, Three-Phase Inverter, Total Harmonic Distortion (THD), Sinusoidal Pulse Width Modulation (SPWM).

I. INTRODUCTION

Uninterrupted power supply (UPS) systems play a vital role in case of utility power failures. It supplies emergency power when power failure occurs. Recently the significance of the UPS system has been increased more and more due to increase of critical and sensitive applications like telecommunication systems, medical equipment, manufacturing of semiconductor devices and data processing systems. Such applications need high reliability and clean power irrespective of the electric power failures and distorted supply voltages. UPS system performance is generally evaluated in terms of steady state /transient response and total harmonic distortion of the output voltage irrespective of load conditions like linear load, nonlinear load and sudden load step change. To enhance the above mentioned performance parameters, several control strategies have been evolved such as adaptive control method, proportional-integral (PI) control method, sliding mode control scheme, model predictive control method, feedback linearization control, deadbeat control method and observer based voltage control method.

The conventional PI control method [2] and [3] is simple for implementation but, the THD of the output voltage is not reduced under nonlinear-load condition. A model predictive control method is suggested in [4]. A load current observer is used in place of current sensors, which resulted in the

reduction of overall system cost. However, the simulation and experimental results do not show better performance in terms of steady-state error and THD. In [5], the deadbeat control method uses the state feedback information to compensate for the voltage drop across the inductor, but this method is sensitive as parameter mismatches. FLC is presented in [6]. This control strategy is proposed to achieve low THD under nonlinear load. However, it is complex due to computations. In [1], the observer based voltage control method is proposed. This method achieved better performance, but involves complex design.

Therefore, this paper proposes Neutral Point Clamped (NPC) inverter with space vector modulation technique, which is well suitable for inverter control. The proposed system would be subjected to fast transient response, small steady state error and low harmonic distortion test under different load conditions. Finally, the comparative results for the proposed scheme and the observer based voltage control scheme are presented to show that the proposed scheme achieves better performance. The results would be tested and verified through Matlab/Simulink. The proposed methodology reduces the total cost, complexity and THD.

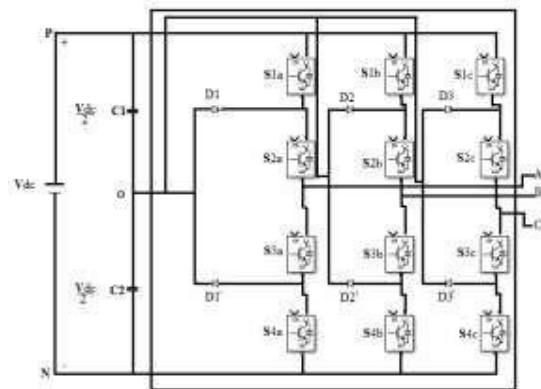

Fig. 1. Three phase NPC inverter.

II. 3-LEVEL NPC INVERTER

Neutral Point Clamped (NPC) or Diode-Clamped inverter is a well-known topology which is widely used in industrial applications [7]. Fig .1 shows the structure of a 3-level three-phase NPC. It needs one DC source as input as shown in Fig .1. Clamping diodes of this topology results in an additional zero voltage at the output. There are 4 switches in each leg of a 3-level NPC so, a total number of $2^4 = 16$ switching states may be possible. By ignoring invalid switching states (the ones leading to a open-circuit or short-circuit in the output) and considering the fact that in phase R (R=a,b or c) the lower switches (S_{3a} , S_{4a}) are always in a contradictory state with respect to the upper switches (S_{1a} , S_{2a}) there will be only 3 effective switching states. Each one of these three

voltages in the output are given in Table I.

State-1 gives a zero voltage by using clamping diodes to connect the neutral point (O) to the output. In the similar manner state-2 gives $+ \frac{V_{dc}}{2}$ by applying voltage of capacitor C1 (reverse voltage of C2) to the output. As an illustration, Fig. 2 shows switching state-2 generates a positive $(+\frac{V_{dc}}{2})$ voltage at the phase output (v_{ao}). As stated earlier, the only change between 3-level NPC and the conventional 2-level full-bridge inverter is clamping diodes. For each leg of an n-level NPC, there would be $(n-1)(n-2)$ clamping diodes and there would be $(n-1)$ DC-link capacitors. Since these capacitors divide the input voltage (V_{dc}) among themselves, nominal voltage rating of each of them would be $V_{dc}/(n-1)$ as well as that of each switches. But in case of an n-level ($n > 3$) NPC inverter, clamping diodes will have different voltage ratings because different reverse voltages might be given to them [8]. 3-level output waveform of this inverter gives high quality output but switching technique is another factor that has to be taken into account.

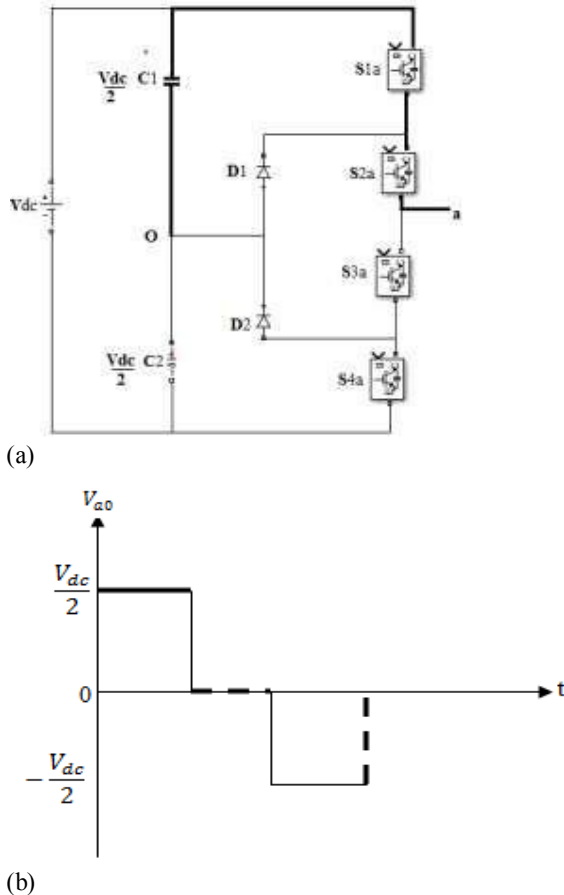

Fig.2. Operating principle of three level NPC. (a) Conducting path. (b). Corresponding output voltage.

TABLE I
SWITCHING STATES OF NPC INVERTER

Switching states	S1a	S2a	S3a	S4a	Inverter Terminal Voltage (Va)
2	On	On	Off	Off	$V_{dc}/2$
1	Off	On	On	Off	0
0	Off	Off	On	On	$-V_{dc}/2$

There are three main switching techniques:

1- Carrier-based methods, 2- Selective Harmonic Modulation (SHE) and 3- Space-Vector Modulation (SVM). In general, SVM method is superior and advanced when compared to the other methods. In the following section a generalized SVM technique has been proposed.

III. SYSTEM CONFIGURATION

The proposed three level inverter with load consists of voltage source inverter. The inverter model connected to the load as shown in Fig 3. This is controlled to produce the sinusoidal output. Three level SVPWM which is based on orientation of reference point in terms of hexagon line is proposed to lower the harmonic contents in the output voltage.

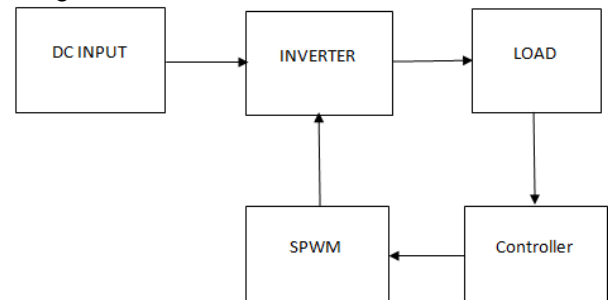

Fig.3. Block diagram of the proposed NPC model.

Each leg of 3-level inverter have switching states of 0,1 or 2. So, 27 switching states can be generated by this inverter. Each one of these switching states can be denoted by a number abc where $abc \in \{0,1,2\}$ which is well explained in [14]. Combination of some switches leads to identical vectors known as redundant switching states. All 27 switching states results in producing only 19 different voltage vectors due to redundant switching states. All the 19 voltage vectors and their respective switching states of a 3-level NPC are represented in table II.

By using parks transformation three phase (abc) voltage vectors is converted to two phase ($\alpha\beta$) plane. On connecting these points a hexagram would be obtained which is SVM diagram of 3-level NPC shown in Fig;4.

TABLE II

THD(%) COMPARISON OF PROPOSED MODEL AND EXISTING MODEL

Model	Step change in load	Unbalanced load	Nonlinear load
Observer based voltage control model	2.74	4.69	35.28
Proposed model	1.57	1.59	8.25

IV. CONTROL DESIGN OF THREE LEVEL INVERTER

For industrial converters applications the sinusoidal PWM technique is the most popular. In the general principle of SPWM, a carrier wave of frequency f_c is compared with the fundamental frequency f sinusoidal modulating wave and the points of intersection indicates the switching points of power devices [9]. There are 8 switching states in the traditional three phase two level inverter and there are 27 switching states in three level inverter. Three level pulse width modulated waveforms can be produced by sine carrier PWM. Sine carrier PWM is generated by comparing the three reference control signals with two triangular carrier waves [10] [11]. The block diagram of the proposed controller is shown in Fig.4.

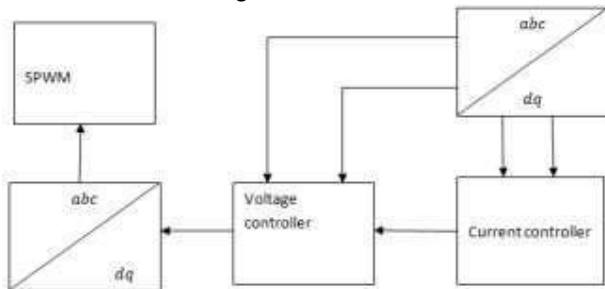

Fig.4. Block diagram of the controller

$$V_i = \begin{cases} 0, & V_{tr} > V_{ref} \\ V_{tri}, & V_{tr} < V_{ref} \end{cases}, \text{ where } i = a, b \text{ or } c$$

The three reference control signals are in a phase shift of 120° each other with same amplitude. Two carrier waves are in phase each other with dc offset voltage.

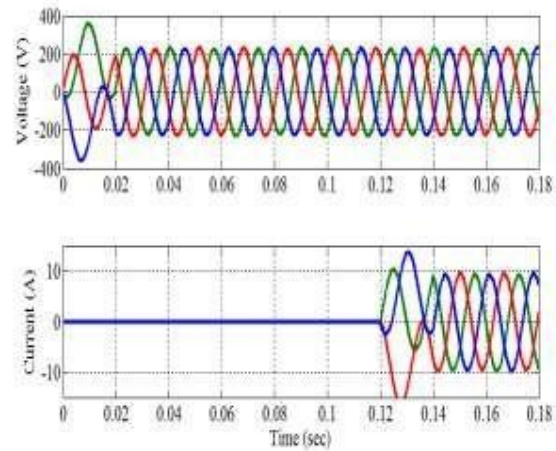

Fig.5. Simulation results of the proposed NPC model under load step change —First: Load output voltages (V), Second: Load output currents (I_L).

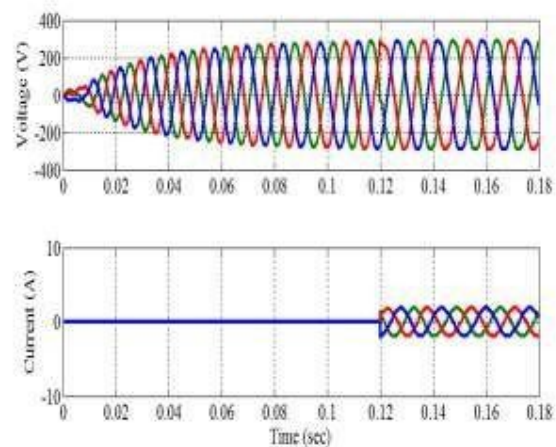
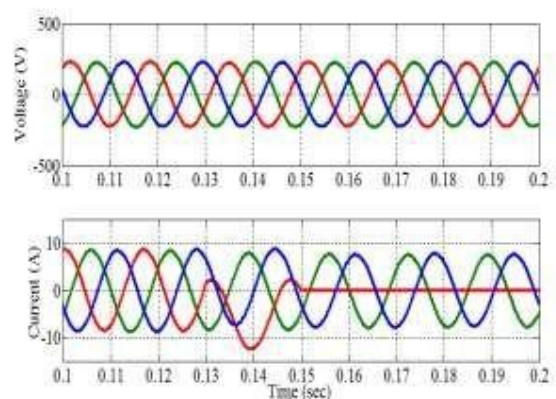

Fig.6. Simulation results of the observer based voltage control model under load step change —First: Load output voltages (V), Second: Load output currents (I_L).



V. SIMULATION RESULTS AND DISCUSSION Simulation was carried out with the help of MATLAB. The proposed technique is carried out under different conditions (i.e., load step change, unbalanced load, and nonlinear load) to clearly represent its merits. The resistive load is subjected to both the load step change condition and the unbalanced load condition (i.e., phase *B* opened) to check the capability of the proposed scheme when the load is suddenly disconnected. To further test the robustness of the proposed technique all load conditions such as load step change, unbalanced load, and nonlinear load are considered.

Fig. 7. Simulation results of the proposed NPC model under unbalanced load (i.e., open phase) —First: Load output voltages (V), Second: Load output currents (I_L).

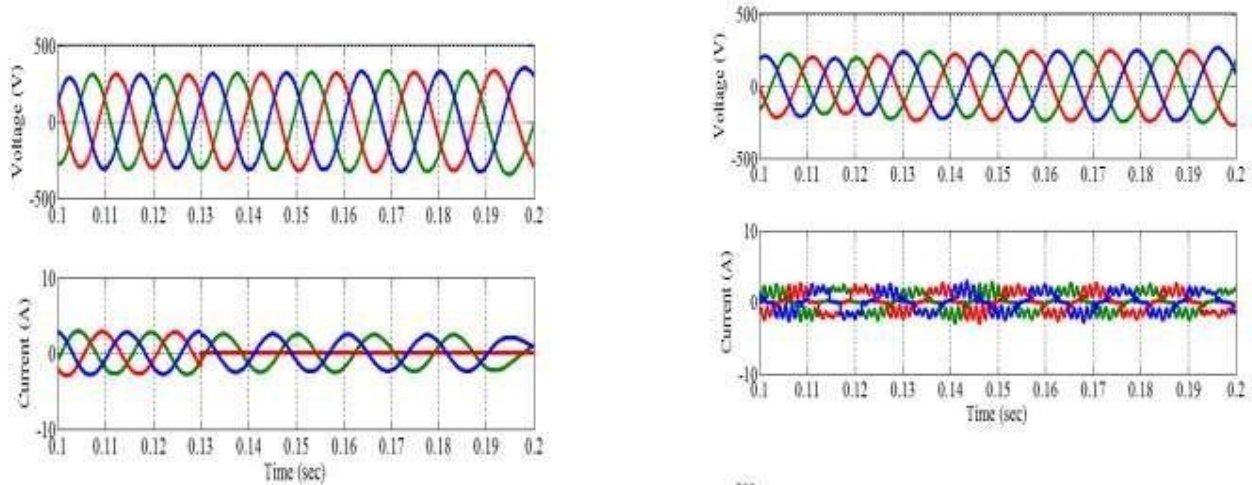

Fig. 8. Simulation results of the observer based voltage control model under unbalanced load (i.e., open phase) — First: Load output voltages (V), Second: Load output currents (I_L).

Fig. 5 shows the simulation results of the proposed control technique during the load step change and Fig. 6 presents the comparative results obtained by employing the optimal voltage control technique under the same condition. Precisely, the figures display the load voltages (First waveform), load currents (Second waveform: I_L). It can be seen in Fig. 5 that when there is a sudden change in load, the output voltage has little distortion. However, it returns to a steady-state condition in 2.0 ms. On the other hand, as shown in the simulation results in Fig. 6, current distortion is longer as compared with that in Fig. 5. Also, the THD values of the load output current at various operating conditions are presented in Table II. These values are found as 2.74% for observer based model and 1.57% using the proposed scheme. Therefore, it is clearly stated that the proposed technique attains lower THD.

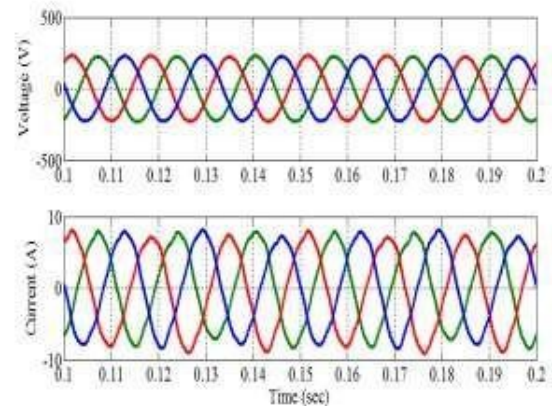

Fig. 9. Simulation results of the proposed NPC model under nonlinear load —First: Load output voltages (V), Second: Load output currents (I_L).

Fig.10. Simulation results of the observer based voltage control model under nonlinear load — First: Load output voltages (V_L), Second: Load output currents (I_L).



The characteristic performances of the transient and steady state under unbalanced load are tested through Figs. 7 and 8. This case is implemented under a situation of full-load condition by suddenly opening phase B . It is shown that the output voltages are well controlled, although there is a rapid change in the load current of phase B is observed as phase B is opened. As shown in Fig. 7 and 8, the corresponding THD values of the output currents are 4.69% for the observer based model and 1.59% using the proposed method.

To estimate the steady-state performance in case of nonlinear load, a three-phase diode rectifier is used. The simulation results of both control methods under this condition are shown in Figs. 9 and 10. The THD values of the load output current waveforms obtained with the

2. U. Borup, P. N. Enjeti, and F. Blaabjerg, "A new space-vector-based control method for UPS systems powering nonlinear and unbalanced loads," *IEEE Trans. Ind. Appl.*, vol. 37, no. 6, pp. 1864–1870, Nov./Dec. 2001.
3. H. Karimi, A. Yazdani, and R. Iravani, "Robust control of an autonomous four-wire electronically-coupled distributed generation unit," *IEEE Trans. Power Del.*, vol. 26, no. 1, pp. 455–466, Jan. 2011.
4. P. Cortés et al., "Model predictive control of an inverter with output LC filter for UPS applications," *IEEE Trans. Ind. Electron.*, vol. 56, no. 6, pp. 1875–1883, Jun. 2009.
5. T. Kawabata, T. Miyashita, and Y. Yamamoto, "Deadbeat control of three-phase PWM inverter," *IEEE Trans. Power Electron.*, vol. 5, no. 1, pp. 21–28, Jan. 1990.
6. D. E. Kim and D. C. Lee, "Feedback linearization control of three-phase," *IEEE Trans. Ind. Electron.*, vol. 57, no. 3, pp. 963–968, Mar. 2010.
7. R. H. Baker, "Switching circuit," ed: Google Patents, 1980.
8. J. Rodriguez, J.-S. Lai, and F. Z. Peng, "Multilevel inverters: a survey of topologies, controls, and applications," *IEEE Transactions on*, vol. 49, pp. 724–738, 2002.
9. Kapil Jain, Pradyumn Chaturvedi—Matlab-based Simulation & Analysis of Three - level SPWM Inverter | International Journal of Soft Computing and Engineering (IJSCE) ISSN: 2231-2307, Volume-2, Issue-1, March 2012.

proposed scheme are 8.25% for proposed model and 35.28% for observer based model, respectively. Finally, all THD values under the three load conditions described earlier are summarized in Table II.

VI. CONCLUSION

This paper has proposed an NPC inverter with simple SPWM for three-phase UPS system. The simulation of the inverter was carried out using sinusoidal pulse width modulation (SPWM). The performance of the proposed control system was demonstrated through simulation under various load conditions (load step change, unbalanced load and nonlinear load). The proposed control scheme achieved a better performance such as lower THD, small steady state error and faster transient response.

REFERENCES

1. Eun-Kyung Kim, Francis Mwasilu, Han Ho Choi, and Jin-Woo Jung—An observer based optimal voltage control scheme for three phase UPS system, *IEEE TRANSACTIONS ON INDUSTRIAL ELECTRONICS*, VOL. 62, NO. 4, APRIL 2015.
10. H. Vahedi and K. Al-Haddad, "Real-Time Implementation of a Packed U-Cell Seven-Level Inverter with Low Switching Frequency Voltage Regulator," *Power Electronics, IEEE Transactions on*, vol. PP, pp. 1–1, 2015.
11. P. Qashqai, A. Sheikholeslami, H. Vahedi, and K. Al-Haddad, "A Review on Multilevel Converter Topologies for Electric Transportation Applications," in *Vehicle Power and Propulsion Conference (VPPC), 2015 IEEE*, 2015, pp. 1–6.
12. Hamid R. Teymour, Kashem M. Muttaqi, "Solar PV and Battery Storage Integration using a New Configuration of a Three-Level NPC Inverter With Advanced Control Strategy," *IEEE TRANSACTIONS ON ENERGY CONVERSION*, VOL. 29, NO. 2, JUNE 2014.
13. Xinbo Ruan, Bin Li, Qianhong Chen, Siew-Chong Tan, "Fundamental Considerations of Three-Level DC DC Converters: Topologies, Analyses, and Control," *IEEE TRANSACTIONS ON CIRCUITS AND SYSTEMS—I: REGULAR PAPERS*, VOL. 55, NO. 11, DECEMBER 2008.
14. Pouria Qashqai, Hani Vahedi, "A general space vector modulation technique for multilevel NPC inverter," *IEEE TRANSACTIONS ON CIRCUITS AND SYSTEMS—I: REGULAR PAPERS*, DECEMBER 2016.
15. H. Tao, J. L. Duarte, and M. A. M. Hendrix, "Line-interactive UPS using a fuel cell as the primary source," *IEEE TRANSACTIONS ON CIRCUITS AND SYSTEMS—I: REGULAR PAPERS*, VOL. 55, NO. 8, Aug 2008.



AUTHORS:

1. Mr. Satish Bandaru obtained his Bachelor of Technology in Electrical and Electronics Engineering from JNT

University, Hyderabad, India. He completed his Master of Technology in Power Electronics from JNT University, Hyderabad, Telangana, India. His area of interest includes Multi Level Inverters, Power Quality, Renewable Energy Sources, FACTS Devices and Electrical Machines. He is currently working as an HOD in Electrical and Electronics Engineering Department in Madhira Institute of Technology and Sciences, Kodad, Telangana, India.



2.Mr.VankudothHathiram obtained his Bachelor of Technology in Electrical and Electronics Engineering from JNT University, Hyderabad, India. He completed his Master of Technology in Power Electronics from JNT University, Hyderabad, Telangana, India. His area of interest includes Multi Level Inverters, Power Quality, Renewable Energy Sources, FACTS Devices and Electrical Machines. He is currently working as Asst.prof in Electrical and Electronics Engineering Department in Madhira Institute of Technology and Sciences, Kodad, Telangana, India



3..**srikanth Borra**.He completed his professional career of education in B.Tech(EEE) at Madhira Institute of Technology and Sciences in the year of 2012 and pursuing M.Tech fromMadhira Institute of Technology and Sciences. he is interested in Power Electronics, Renewable EnergySourcesandFACTS.