

Thermal Analysis of a Steam Turbine Propeller Blade

M. Gayatri

DEPARTMENT OF THERMAL ENGINEERINGKG
REDDY COLLEGE OF ENGINEERING
&TECHNOLOGY

K. Udaya Sree

ASSISTANT PROFESSOR
DEPARTMENT OF THERMAL ENGINEERINGKG
REDDY COLLEGE OF
ENGINEERING&TECHNOLOGY

ABSTRACT

Steam turbine is an excellent prime mover to convert heat energy of steam to mechanical energy. Of all heat engines and prime movers the steam turbine is nearest to the best and it is widely used in power plants and in all industries where power is needed for process. In power generation mostly steam turbine is used because of its greater thermal efficiency and higher power-to-weight ratio. Because the turbine generates rotary motion, it is particularly suited to be used to drive an electrical generator—about 80% of all electricity generation in the world is by use of steam turbines. In this project we are going to design a propeller blade assembly in Catia V5 R21 and thermal analysis is done in Ansys. In order to evaluate the effectiveness of composites and metal propeller using FEA packaged (ANSYS). Thermal analysis is performed on both Aluminum and composite propeller to find out the heat flux and thermal error.

INTRODUCTION

A turbine is a rotary mechanical device that extracts energy from a fluid flow and converts it into useful work. A turbine is a turbo machine with at least one moving part called a rotor assembly, which is a shaft or drum with blades attached. Moving fluid acts on the blades so that they move and impart rotational energy to the rotor. Early turbine examples are windmills and waterwheels.

The first turbines to be used were the steam turbines but now on the basis of the fluid from which energy is extracted there are four major types of turbines:

- Steam turbines
- Water turbines
- Wind turbines

Steam Turbine

Steam turbines use up high pressure steam to produce energy. These turbines are not used for producing electricity but they are used to propel jet engines. Steam turbines are the latest types of turbines. Their structure is advanced but the principle is same.

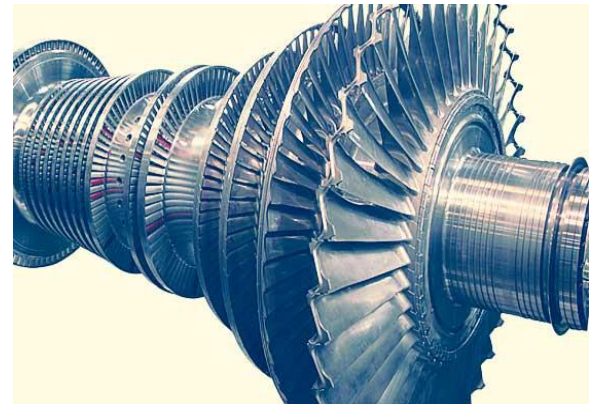

How Do Steam Turbine Work?

Steam turbines are comprised of three primary sections mounted on the same shaft: the compressor, the combustion chamber (or combustor) and the

turbine. The compressor can be either axial flow or centrifugal flow. Axial flow compressors are more common in power generation because they have higher flow rates and efficiencies. Axial flow compressors are comprised of multiple stages of rotating and stationary blades (or stators) through which air is drawn in parallel to the axis of rotation and incrementally compressed as it passes through each stage. The acceleration of the air through the rotating blades and diffusion by the stators increases the pressure and reduces the volume of the air. Although no heat is added, the compression of the air also causes the temperature to increase.



The compressed air is mixed with fuel injected through nozzles. The fuel and compressed air can be pre-mixed or the compressed air can be introduced directly into the combustor. The fuel-air mixture ignites under constant pressure conditions and the hot combustion products (steames) are directed through the turbine where it expands rapidly and imparts rotation to the shaft. The turbine is also comprised of stages, each with a row of stationary blades (or nozzles) to direct the expanding steames followed by a row of moving blades. The rotation of the shaft drives the compressor to draw in and compress more air to sustain continuous combustion. The remaining shaft power is used to drive a generator which

produces electricity. Approximately 55 to 65 percent of the power produced by the turbine is used to drive the compressor

INTRODUCTION TO CATIA

CATIA also known as **Computer Aided Three-dimensional Interactive Application** and it is

software suit that developed by the French company call Dassult Systems.

CATIA is a process-centric computer-aided design/computer-assisted manufacturing/computer-aided engineering (CAD/CAM/CAE) system that fully uses next generation object technologies and leading edge industry standards. CATIA is integrated with Dassult Systems Product Lifecycle Management (PLM) solutions. It allows the users to simulate their industrial design processes from initial concept to product design, analysis, assembly and also maintenance. In this software, it includes mechanical, and shape design, styling, product synthesis, equipment and systems engineering, NC manufacturing, analysis and simulation, and industrial plant design. It is very user friendly software because CATIA Knowledge ware allows broad communities of user to easily capture and share know-how, rules, and other intellectual property assets.

Engineering Design

Catia V5 offers a range of tools to enable the generation of a complete digital representation of the product being designed. In addition to the general geometry tools there is also the ability to generate geometry of other integrated design disciplines such as industrial and standard pipe work and complete wiring definitions. Tools are also available to support collaborative development.

A number of concept design tools that provide up-front Industrial Design concepts can then be used in the downstream process of engineering the product. These range from conceptual Industrial design sketches, reverse engineering with point cloud data and comprehensive freeform surface tools.

DESIGN

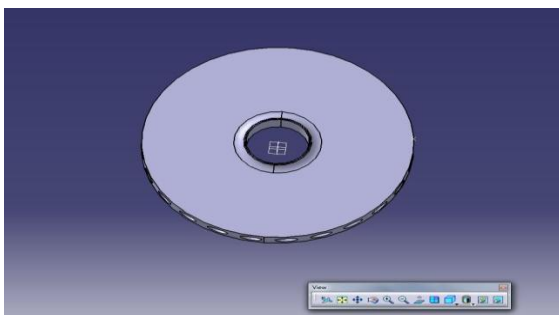
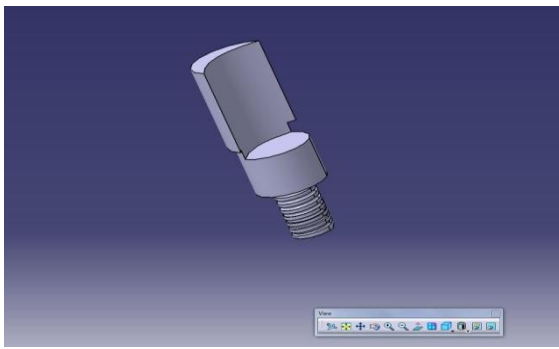

ASSEMBLY MODEL

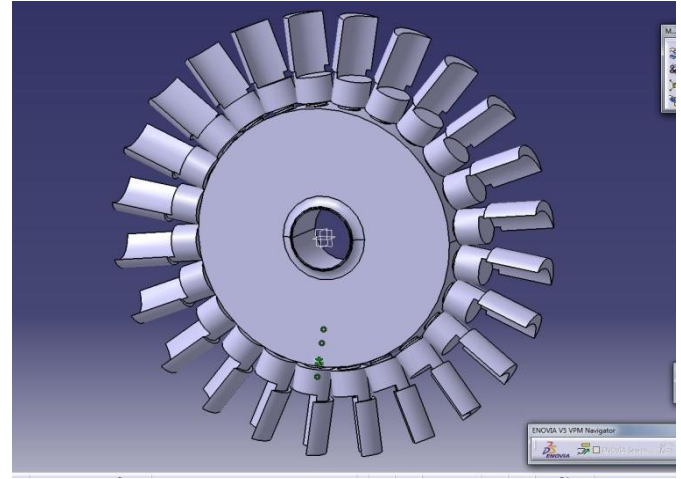

INTRODUCTION TO ANSYS

ANSYS is general-purpose finite element analysis (FEA) software package. Finite Element Analysis is a numerical method of deconstructing a complex system into very small pieces (of user-designated size) called elements. The software implements equations that govern the behaviour of these elements and solves them all; creating a comprehensive explanation of how the system acts as a whole. These results then can be presented in tabulated, or graphical forms. This type of analysis is typically used for the design and optimization of a system far too complex to analyze by hand. Systems that may fit into this category are too complex due to their geometry, scale, or governing equations.

ANSYS is the standard FEA teaching tool within the Mechanical Engineering Department at many colleges. ANSYS is also used in Civil and Electrical Engineering, as well as the Physics and Chemistry departments.

Generic Steps to Solving any Problem in ANSYS

Like solving any problem analytically, you need to define (1) your solution domain, (2) the physical model, (3) boundary conditions and (4) the physical properties. You then solve the problem and present the results. In numerical methods, the main difference is an extra step called mesh generation. This is the step that divides the complex model into small elements that become solvable in an otherwise too complex situation. Below describes the processes in terminology slightly more attune to the software.

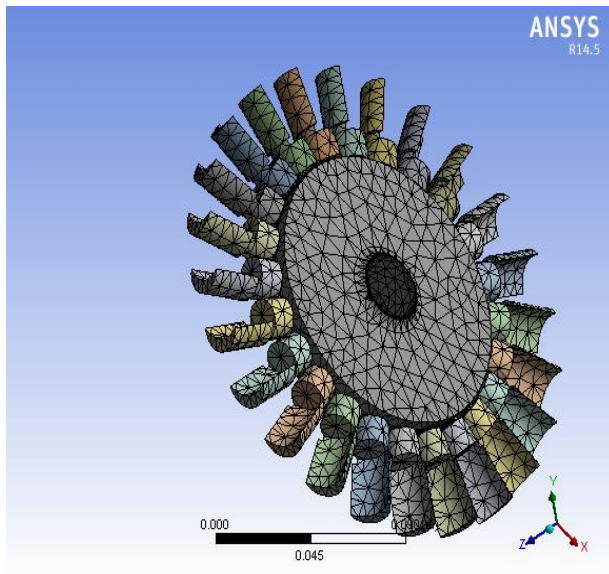

**Model (A4, B4) > Steady-State Thermal
(A5) > Temperature**

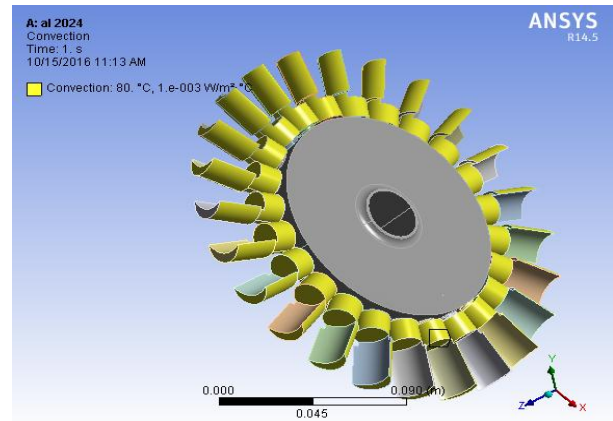
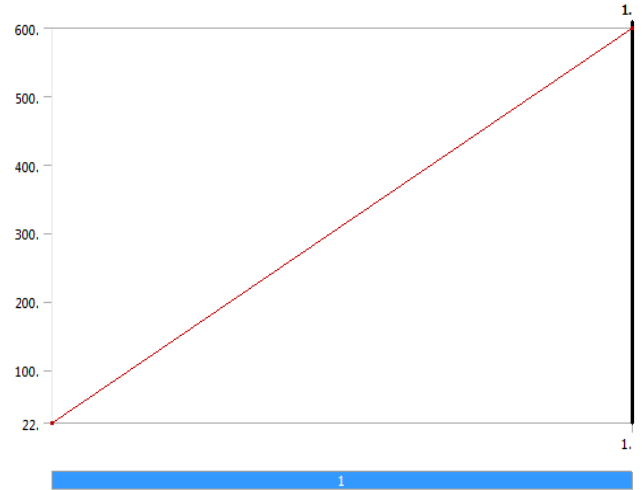

**Model (A4, B4) > Steady-State Thermal
(A5) > Convection**

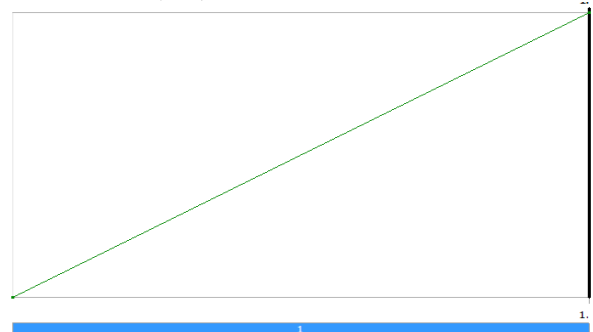

TABLES

		Al 2024	C-C Composites	HM-CFRP 10%
TEMPERATURE	MIN	516.37	425.05	226.9
	MAX	600	600	600
TOTAL HEAT FLUX	MIN	1341.5	1209.1	184.88
	MAX	1.9023E6	1.0098E6	1.876E5
DIRECTIONAL HEAT FLUX	MIN	-1.39688E6	-7.3828E5	-1.5414E5
	MAX	1.7645E6	9.22866E5	1.8054E5
THERMAL ERROR	MIN	4.3002E-7	3.3445E-7	7.8003E-8
	MAX	83.246	123.38	116.81
THERMAL STRESS	MIN	6.7001E-11	1.0358E-10	8.8351E-12
	MAX	0.53364	0.70428	0.056365
DEFORMATION	MIN	1.1656E-15	1.1588E-15	1.1556E-15
	MAX	1.7879E-14	1.7886E-14	1.7886E-14

CONCLUSION

In this project we are going to conduct the stress and deformation of a steam turbine rotor blade assembly. As here we are going to consider the materials AL 2024, Carbon Carbon Composites and high modulus – carbon fiber reinforced polymer of 10%. As here the designed is done in Catia v5 and analysis is done in Ansys software, here we are going to conduct thermal and structural of the model in Ansys software.

As here we have done the analysis here we have done in the assembly model, after the analysis all obtained results are formed in a tubular form and graphs are tabulated, as we compare the results obtained we can observe that the HM-CFRP 10% material has got a large variation in results as this can be considered as

a best material for the better life output of the material.

As here we observed in the structural analysis, here also the same repeated as the HM-CFRP 10% material has got the better output with best results in the structural analysis as the deformations are very better than the other materials, so by all these results here we can conclude that the HM-CFRP 10% will be the better material for the better life efficiency and better life output for the product.

REFERENCES

- 1) Heat Transfer data handbook, General Electric Company, Schenectady, NY. (1976)
- 2) Convective Heat and Mass transfer, Kays , W.M, Tata McGraw Hill Publication (1975)
- 3) Analysis of Heat and Mass Transfer, Eel-cert, E.R.G and Drake, R.i\|I. Hemisphere Publishing Corporation (1987)
- 4) Krishnarnoorthy.V. andPai.B.R. Heat Transfer coefficient distribution around hub, mean and tip section profiles of high pressure turbine nozzle guide vane of kaveri engine, NAL PD PR 9118 (1991)
- 5) The Finite Element Method in Heat Transfer and Fluid Dynamics, I. N. Reddy, David K. Gartling (Contributor)
- 6) Numerical Methods in Heat Transfer Roland W. Lewis, et al Analysis of Heat and Mass Transfer
- 7) Analysis of Heat and Mass Transfer Emst R.G. Eckert Shilpa P. Bhorkar, Dr. A.V. Vanalkar / International Journal of Engineering Research and Applications (IJERA) ISSN: 2248-9622 www.ijera.com Vol. 2, Issue 3, May-Jun 2012, pp.2248-2252 2252 | P a g e

8) Boundary Element Techniques?Applications in Stress Analysis and Heat Transfer (Topics in Engineering Series) C.A. Brebbia, W.S. Venturini (Editor)

9) Finite Element Analysis for Heat Transfer, Theory and Software, Hon-Cheng Huang, A. S. Usmani (Contributor)

10) The Finite Element Method in Heat Transfer Analysis R. W. Lewis (Editor), K. Morgan 11) Handbook of Numerical Heat Transfer, W}. Mini-rowycz, et al "

12) An Introduction to Convective Heat Transfer Analysis (McGraw-Hill Series in Mechanical Engineering) David Naylor, Patrick H. Dosthuizen

13) An introduction to Mass and Heat Transfer: Principles of Analysis and Design, Stanley Middleman

14) Numerical Heat Transfer, Tien—Mo Shih

15) Determination of stress concentration factors of a steam Turbine rotor by FEA, R. NagendraBabu, K.V., Ramana, and K. MallikarjunaRao