

Bus Security and Tracking System Using GSM

SHAMILI

Velaga Nageswara Rao college Of Engineering
Ponnur

N.V Raghava swamy

Associate professor
Velaga Nageswara Rao college Of Engineering
Ponnur

ABSTRACT: This paper summarizes our work on the design and implementation of GSM-based system for tracking the location of buses provided for public transportation. The system consists of three main modules: In-Bus Module, Bus-Stop Module and Base-Station Module. When bus leaves from BASE Station, the GSM tag at BASE-Station is read by the GSM reader in the In-Bus Module and the tag data is then sent to BASE-Station via GSM. By using the signals from AT89S52 microcontroller, GSM modem is used to send appropriate GSM tag data to the BASE-Station. An entry corresponding to the bus is created and entered into the database at BASE-Station. BASE-Station Module sends the data about bus, its current location and remaining time for arriving particular bus stop to the Bus-Stop modules via GSM. Bus-Stop Module is installed at every bus stop and consists of GSM, GSM tag and LCD display all interfaced to a microcontroller. This module then display the data received form BASE-

Station on LCD displays. AT89S52 microcontroller is the main controlling device which controls and synchronizes all the operations by receiving the data from GSM tag. This paper is embedded based, embedded means dumping of software in to the hardware. Here software code is written and debugged with the help of micro version Keil. Keil converts the asm file into hex file and this software code is dumped into the microcontroller AT89S52 using dumping kit.

Keywords— *GSM reader; GSM; LCD Display; GSM Tag; Microcontroller; Keil software*

INTRODUCTION

An embedded based project consists of microcontroller, input section and output section. In this project, in the input section, it contains peripherals such as switches, GSM reader and the output section consists of LED's, LCD display and GSM modem. In this paper, AT89S52 is used. It acts as interface between GSM tags and GSM. AT89S52, in this AT is the ATMEL series,

89 is the series number, S represents serial communication or parallel communication and 52 is the series number [7]. AT89S52 is a low power, high performance CMOS 8-bit microcontroller with 8K bytes of flash, 256 bytes of RAM, 32 I/O lines, two data pointers, a full duplex serial port. In order to provide 5V or 12V supply, it consists of bridge rectifier and regulators. Microcontroller needs 5V power supply and other peripherals such as GSM and GSM Reader needs 12V power supply. It uses two regulators namely MC7805 and MC7815 for maintaining constant voltage. A switch is connected to reset pin of microcontroller to reset the circuit.

Due to non-availability of the prior information about bus arrival schedule, people have to wait for longer on bus stops especially in morning when they have to reach the offices in time. The travel time of buses varies depending on several external parameters such as accidents and traffic. Buses are stuck in traffic and are hampered by the passage of junctions which makes the management of the bus schedule in the BASE stations a difficult task. BASE station follows fixed schedules and don't make use of intelligent systems. Many employees are deployed at the station who controls the

entrance and exit of buses and manually prepares the trip sheets of buses containing the schedules which are time consuming and inaccurate. Even public transport departments have no visibility over utilization of its fleet, which leads in underutilization of resources. The provision of accurate travel time information is so important. With the help of new technology the administrator can monitor the buses traffic while increasing the satisfaction of passengers and reducing cost through efficient operations. Well-known examples of identification technologies include Closed-Circuit Television (DISPLAY) and Global Positioning System (GPS). DISPLAY can be deployed at each entrance gate and image processing techniques can be utilized to identify the arrival of buses, where image recognition was performed to detect the bus in the traffic. This testing has shown poor performance in tracking based detection (~20%precision). During the past, GPS integrated to Geographic Information Systems (GIS) was used to monitor buses traffic. GPS receiver communicates with at least 4 satellites before giving the location of the bus. It gives a very good forecasting. However, line of sight between the satellites and the receiver is required otherwise the GPS signal is attenuated. The main

limitation of this technology is especially when it comes to monitor bus traffic inside an underground bus station.

Due to the limitation of these technologies, the GSM technology can be used to track bus locations. GSM technology can be effectively applied for real-time tracking and identification. GSM technology can response to our tracking needs that's why we used GSM in our project to identify buses entering and leaving the bus stops and BASE stations.

PROPOSED SYSTEM MODULES

The proposed system architecture for intelligent bus management and monitoring system is shown in Fig. 1. A black-box containing GSM reader, GSM modem is equipped in the moving bus. As the bus approaches a bus stop with an GSM tag, the distance between the reader and the tag decreases so that they can interact with each other. This communication also produces data and the data gained is sent to the BASE-Station via GSM. The entire system consists of three modules: BASE-Station Module, In-Bus Module and Bus-Stop Module. The architecture and working of these modules is described in this section.

BASE-Station Module

This module is the central part of the system and consists of a GSM modem connected to the computer. It accepts the location information of the buses via respective GSM modems and stores it in the database. It sends the data about bus, its current location and remaining time for arriving particular bus stop to the Bus-Stop modules via GSM. The message received is of the form “#BFF23D4AF56F1”. The first character is used to distinguish this message from other messages. The second character denotes the message contains the information about the bus stops. The remaining twelve characters denote the current location information.

The PC at BASE-Station compares the above twelve characters in database and determines the bus stop name corresponding to that 12-digit code. After processing the received data BASE-Station sends the location information in the form of “#101CORPORATION20” to the Bus-Stop Modules. The “101” denotes the route number of the bus. The “CORPORATION” denotes the current location of bus. The “20” denotes the remaining time of the bus to reach at respective Bus-Stop Module. The block diagram of the BASE-Station module is shown in Fig. 2. BASE-Station also monitors the emergency situations transmitted from In-bus Module.

Bus Section

Bus stop Indication

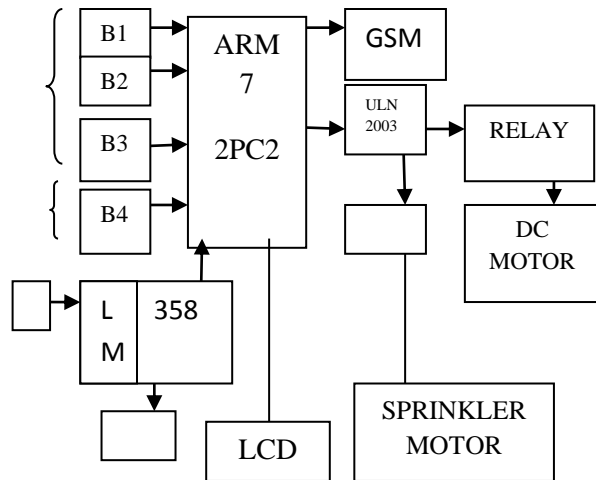

The above diagram shows that, the Bus indicators shows the exact place of the bus when the bus reaches the bus stops i.e, B1, B2, B3,..... As bus reaches one point to another point the indicator will send the message to the GSM from the bus.

There is another use of this program, that is, when there is a fire accident in the bus, immediately the indicator sends the message to the GSM as well as to the Relay-1 and Relay - 2. And these send the information to the LCD projector as well as to the DC motor. These will send the signals to the Sprinkler motor. It will rescue the problem.

The actual GSM works as follows.

Bus Stop Section

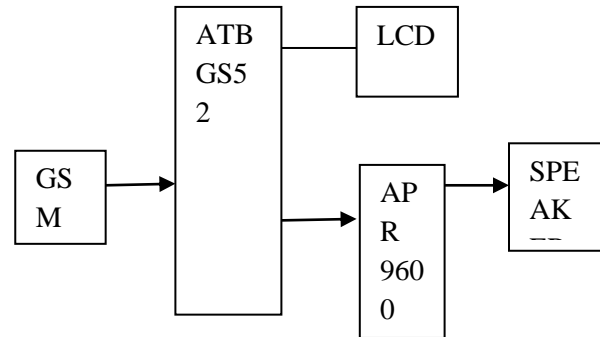

The above block diagram shows the working of GSM at the bus station or bus stop. It will show the exact place of the bus in that time.

When the bus starts from B1 it will give information at the LCD at the bus stop. That is the bus with number APR9600 will arrive B2 for this time. And it will be announced by the speaker at the bus stop. This will be very useful to the passengers waiting at the bus stop.

This module is installed inside every bus and consists of a GSM modem, a GSM Reader, emergency buttons like Bus-Failure, Bus-Delay; all interfaced to the AT89S52 microcontroller. After leaving form source BASE Station, this module starts transmitting the bus location to the BASE Station. At each stop, when the distance between the bus and GSM tag at Bus stop

decreases, the GSM Reader at the entry door of the bus reads the GSM tag and transmits this data to BASE-Station Module. In case of emergency situations the driver can press the Bus-Failure or Bus-Delay button to inform to the BASE station. The BASE Station operator can then adjust the schedule accordingly and send an additional bus for facilitating the passengers. The Bus-Stop Module is installed at every bus stop to let the passenger know about the location of buses coming towards that bus stop. It comprises of a GSM modem and LCD display; all interfaced to AT89S52 microcontroller. A sample message received by Bus-Stop Module is of the form “#101CORPORATION20”. The message contains the information about those buses only which will pass by the designated stop. First three digits after “#” denote the bus route number followed by the bus stop name followed by the remaining time of the bus coming towards the specified bus stop. Microcontroller displays it on LCD display.

HARDWARE DESCRIPTION

The hardware circuits for In-Bus Module and Bus-Stop Module is described below:

A. In-Bus Module

The supply to the circuit is obtained from the power supply circuit. The power supply circuit consists of regulator MC7805 which produces 5V supply to the microcontroller. The AT89S52 consists of four ports which can be used for both input and output. The circuit uses port1 as input, port3 and port0 as in-out, port2 as output ports. The switch is connected to pin9 to reset the circuit. The crystal oscillators which are internally present in the microcontroller produce frequency which is varying. The GSM Reader is used to read the GSM tags at bus stops. It is connected to port3 which acts as in-out to the microcontroller. GSM modem is connected to port 3 which is in-out. The GSM Reader and GSM are interfaced to microcontroller using MAX232. The communication between GSM circuit and microcontroller is done by using serial communication. For this it uses RS232 port. The microcontroller logic levels and RS232 logic levels are not equal. Thus to match the logic levels MAX232 is used to interface GSM modem. The LCD display is connected to port0 and port2 which are in-out and output respectively. It is used to display the current bus location. At the port0 there are no pull up resistors inbuilt in it to produce 5V supply for LCD display. So, to activate LCD display external pull up

resistors are connected at port0 to produce 5V supply. The emergency buttons are also connected to the port0 which is in-out. When the GSM reader reads the tag, the appropriate signals are transmitted to the LCD and it displays the current bus location. The signals from the microcontroller also sent to the GSM modem according to the software code dumped in the microcontroller. The GSM modem then transmits the current location (GSM Tag data) to the BASE-Station Module.

Bus-Stop Module

The supply to the circuit is obtained from the power supply circuit. The power supply circuit consists of regulator which produces 5V supply to the microcontroller. The circuit uses port1 and port3 as input, port0 and port2 as output ports. The switch is connected to pin9 to reset the circuit. GSM modem is connected to port 3 which is input. The GSM is interfaced to microcontroller using MAX232. The communication between GSM circuit and microcontroller is done by using serial communication. For this it uses RS232 port. The microcontroller logic levels and RS232 logic levels are not equal. Thus to match the logic levels MAX232 is used to interface GSM modem. The LCD display is connected to port0 and port2 which are

output. It is used to display the current bus location. At the port0 there are no pull up resistors inbuilt in it to produce 5V supply for LCD display. So, to activate LCD display external pull up resistors are connected at port0 to produce 5V supply.

BASE-Station Module

In this module, GSM modem is connected to the computer through serial cable. The power adapter is used to provide power supply to the GSM modem.

SOFTWARE DESCRIPTION

As this project is embedded based project, the software code is written in assembly language which is compiled, debugged and tested. It is simulated with the help of micro vision Keil which control the execution of assembly language programs. The programming at BASE-Station Module is done using Microsoft Visual Basic. All the database tables are created in the Oracle 10G.

About KEIL Software

It is possible to create source files in a text editor such as Notepad, specifying a list of controls, run the compiler and assembler, linker and finally running the Object-HEX Converter to convert the linker output file to a Hex File.

- First select the text mode for SMS by sending following AT command to GSM modem: AT+CMGF=1. This command configures the GSM modem in text mode.
- Send the following AT command for sending MS message in text mode along with mobile number to GSM modem:
AT+CMGS=+911231231230.
- Send the text message string to the GSM modem.

RESULTS

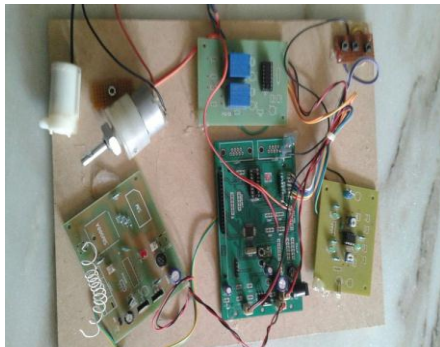

CONCLUSION

In accordance with the situation of the public transport management system at present, we design a new intelligent bus management system by using GSM technology and GSM technology. We have performed small scale tests on the project. Cost effective SMS service of GSM modem is used for the transfer of data between the modules in the project. Its low cost makes it easy to accept by public transportation Corporation. The LCD displays are installed at bus stop to let them know the buses location coming towards the bus stop. The system is also efficient in handling the emergency situations e.g., in case of any technical fault occurred in the bus, the operator at BASE-Station is informed and the departure time between the buses is reduced. In case of the traffic, the passengers waiting at the bus stops can be informed with the delay. It is believed that by the implementation of this system, various problems like underutilization of bus fleet and long waiting time at the bus stops will be reduced. So, both BASE Station administrator and passenger will benefit from this system. It can improve the quality of the public transportation service effectively.

FUTURE WORK

An automatic route guider display can be installed in buses to get better updates on the alternative routes in case of serious road congestions. Fare collecting system can also be automated by providing another mobile service to which all the passengers using public transportation service are subscribed. The information about the current locations of the buses can be provided on mobile (by developing some application) so that the user can adjust his schedule accordingly.

REFERENCES

- [1] M. A. HANNAN, A. M. MUSTAPHA, A. HUSSAIN and H. BASRI, "Intelligent Bus Monitoring and Management System", WCECS 2012, October 24-26, 2012, San Francisco, USA
- [2]. Ben Ammar Hatem, Hamam Habib, "Bus Management System Using GSM in WSN", European and Mediterranean Conference on Information Systems 2010
- [3]. Akshay Bal, "GSM BASED IDENTIFICATION SYSTEM", April 2009
- [4]. LV ZHIAN HU HAN, "A Bus Management System Based on ZigBee and GSM/GPRS", 2010 International Conference on Computer Application and System Modeling (ICCASM 2010)
- [5]. Umar Farooq, Tanveer ul Haq, Senior Member IEEE, Muhammad Amar, Muhammad Usman Asad, Asim Iqbal, "GPS-GSM Integration for Enhancing Public Transportation Management Services", 2010 Second International Conference on Computer Engineering and Applications
- [6]. José I. San Jose, José M. Pastor, R. Zangróniz, Juan J. de Dios, "GSM Tracking for urban transportation using EPCGlobal-based WebServices", 2013 27th International Conference on Advanced Information Networking and Applications Workshops
- [7]. Teki, Naga. Padmaja, Tejavath. Renuka, Anantha. Sushmitha. Srilakshmi, "Design of GSM Based Smoke Detection and Temperature Monitoring System", International Journal of Engineering Research & Technology (IJERT) Vol. 2 Issue 4, April – 2013 ISSN: 2278-0181
- [8]. Ding Yi, "Electronic Bus Stop Boards Promote the Intelligent Construction of Urban Public Transportation", 2010 International Conference on Computer Design And Applications (ICDDA 2010)
- [9]. Shing Tenqchen, Foun-Shea Chang, Yong-Chun, Lee, Ching-Hung Wang, Chao-Hao Lee, Shen-Lung Tung, "Helping to Collect Traffic Information Using GSM Tag Implemented on Urban-bus for Traffic Information", Proceedings of Asia-Pacific Microwave Conference 2006
- [10]. Wiroom Sriborriuxl, Panuwat Danklangl and Nakorn Indra- Payoong, "The Design of GSM Sensor Network for Bus Fleet Monitoring"
- [11]. Aishah Mahani Mustapha, MA Hannan, Aini Hussain and Hassan Basri, "UKM Campus Bus Monitoring System Using GSM and GIS", 2010 6th International Colloquium on Signal Processing & Its Applications (CSPA)
- [12]. ZhuY, Liu Yanjuan, "Intelligent Bus-Mounted System Based On GSM", 2012 International Conference on Computer Science and Information Processing (CSIP)